



Main

Range of product	Modicon M340 automation platform
Product or component type	Discrete input module
Electrical connection	20-way connector
Discrete input number	16
Discrete input type	Isolated
Input type	Resistive
Discrete input voltage	24 V AC 24 V DC negative
Discrete input current	3 mA
Input compatibility	With 2-wire/3-wire proximity sensors conforming to IEC 60947-5-2

Complementary

Network frequency	50/60 Hz
Network frequency limits	47...63 Hz
Sensor power supply	20...26 V
Voltage state 1 guaranteed	≥ 15 V
Current state 1 guaranteed	≥ 2 mA
Voltage state 0 guaranteed	≤ 5 V
Current state 0 guaranteed	≤ 1 mA
Input impedance	6400 Ohm
Insulation resistance	> 10 MOhm 500 V DC
Power dissipation in W	≤ 3 W
DC typical filtering time	10 ms
DC maximum filtering time	20 ms
AC activation filtering time	15 ms
AC deactivation filtering time	20 ms
Paralleling of inputs	No
MTBF reliability	1504958 h
Protection type	1 external fuse per group of channel 0.5 A fast blow
Voltage detection threshold	< 14 V DC sensor fault > 18 V DC sensor OK
Status LED	1 LED green module operating (RUN) 1 LED per channel green channel diagnostic 1 LED red module error (ERR) 1 LED red module I/O
Product weight	0.115 kg

Environment

IP degree of protection	IP20
Standards	CSA 22-2 No 142 IEC 1131-2 IEC 664 NF C 63-850 UL 508 UL 746C
Dielectric strength	1500 V AC at 50/60 Hz 1 minute, primary/secondary
Ambient air temperature for operation	0...60 °C
Relative humidity	10...95 % without condensation
Protective treatment	TC

The information provided in this documentation contains general descriptions and/or technical characteristics of the performance of the products contained herein. This documentation is not intended as a substitute for and is not to be used for determining suitability or reliability of these products for specific user applications. It is the duty of any such user or integrator to perform the appropriate and complete risk analysis, evaluation and testing of the products with respect to the relevant specific application or use thereof. Neither Schneider Electric Industries SAS nor any of its affiliates or subsidiaries shall be responsible or liable for misuse of the information contained herein.

Modules Mounted on Racks

Dimensions

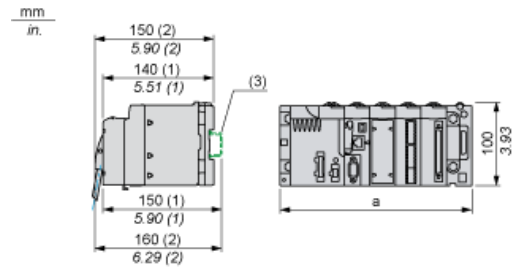

- (1) With removable terminal block (cage, screw or spring).
 (2) With FCN connector.
 (3) On AM1 ED rail: 35 mm wide, 15 mm deep. Only possible with BMXXBP0400/0400H/0600/0600H/0800/0800H rack.

	a in mm	a in in.
BMXXBP0400 and BMXXBP0400H	242.4	09.54
BMXXBP0600 and BMXXBP0600H	307.6	12.11
BMXXBP0800 and BMXXBP0800H	372.8	14.68
BMXXBP1200	503.2	19.81

Connecting the Module

Input Circuit Diagram

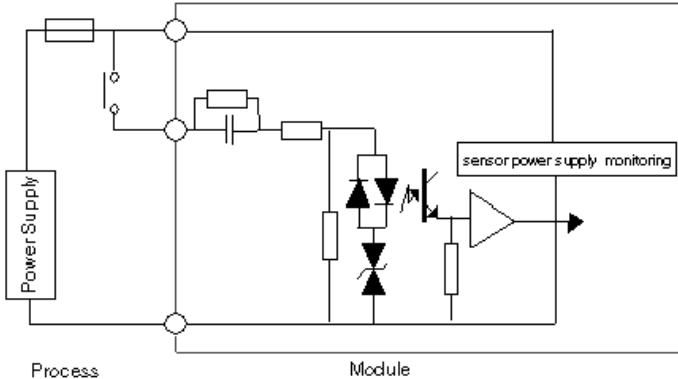

Module Connection (AC Power Supply)

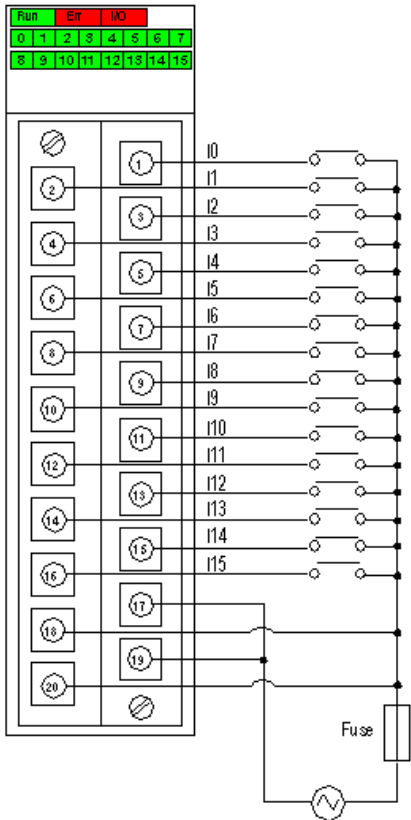

power24 VAC
supply
fuse fast blow fuse of 0.5 A

Module Connection (DC Power Supply)

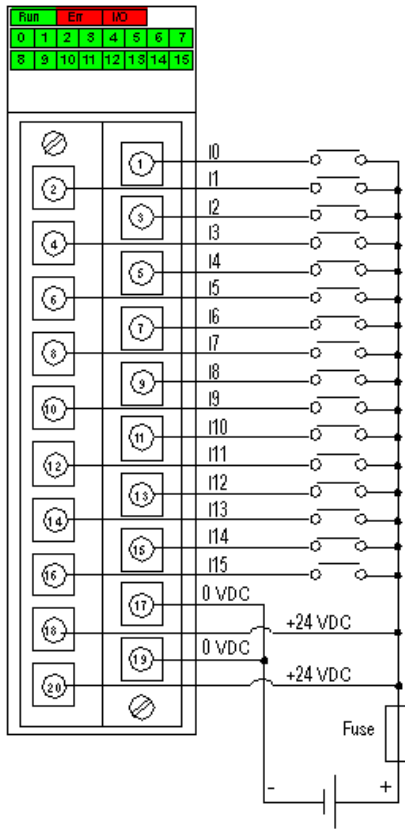

Positive Logic Wiring

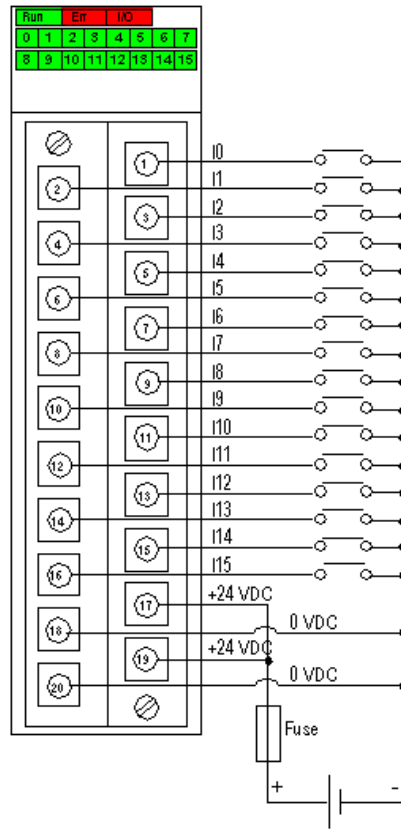

Negative Logic Wiring

power 24 VDC
supply
fuse fast blow fuse of 0.5 A