



Main

Range of product	Phaseo
Product or component type	Battery module
Input voltage	24 V DC
Output voltage	24 V DC
Maximum output current	32 A
Battery capacity	3.2 AH
Holding time	< 20 h at 0.16 A , 20 °C > 5 min at 8.4 A , 20 °C

Complementary

Input voltage limits	21...29 V
Load current	0.3 A
Charging time	<= 72 s
Output protection type	Against overload and short-circuits , protection technology: 1 x 20 A automotive type fuse
Connections - terminals	Screw type terminals for input connection , connection capacity: 2 x 0.5...2 x 10 mm ² AWG gauge20...8 Screw type terminals for output connection , connection capacity: 2 x 0.5...2 x 10 mm ² AWG gauge20...8
Self-discharge rate	15 % , 6 months 3 % , 1 month 9 % , 3 months
Fixing mode	By 2 screws , screw(s) Ø = 5 mm on horizontal panel , operating position: horizontal By 4 screws , screw(s) Ø = 5 mm on vertical panel , operating position: vertical By clips (with mounting kit) on 35 mm symmetrical DIN rail , operating position: horizontal By clips (with mounting kit) on 35 mm symmetrical DIN rail , operating position: vertical
Output coupling	Parallel
Service life in hours	11000 h at 40 °C 15000 h at 35 °C 22000 h at 30 °C 31000 h at 25 °C 44000 h at 20 °C 5000 h at 50 °C 7300 h at 45 °C
Product weight	3.5 kg

Environment

IP degree of protection	IP10 conforming to EN/IEC 60529
Ambient air temperature for operation	0...40 °C
Ambient air temperature for storage	-20...50 °C
Class of protection against electric shock	Class III conforming to VDE 0106-1
Vibration resistance	3.5 mm (f = 3...11.9 Hz) conforming to EN/IEC 61131-2 2 gn (f = 11.9...150 Hz) conforming to EN/IEC 61131-2

The information provided in this documentation contains general descriptions and/or technical characteristics of the performance of the products contained herein. This documentation is not intended as a substitute for and is not to be used for determining suitability or reliability of these products for specific user applications. It is the duty of any such user or integrator to perform the appropriate and complete risk analysis, evaluation and testing of the products with respect to the relevant specific application or use thereof. Neither Schneider Electric Industries SAS nor any of its affiliates or subsidiaries shall be responsible or liable for misuse of the information contained herein.

24 Vdc Battery Module

Dimensions

mm
inch

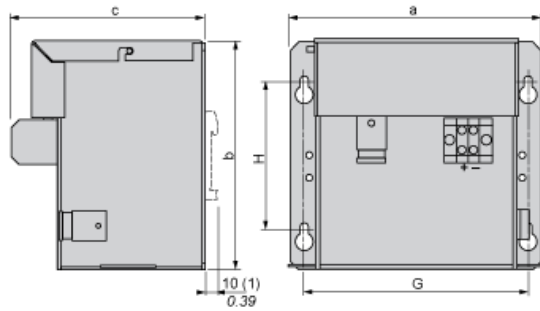

ABL	a	b	c	G	H
8BPK24A03	184/7.24	138.5/5.45	131	156/6.14	83/3.27
8BPK24A07	170/6.69	155.5/6.12	131	152/5.98	100/3.94
8BPK24A12	236/9.29	155.5/6.12	131	218/3.94	100/3.94

(1) ABL8BPK24A03 (with kit ABL1A02)

24 Vdc Battery Module

Mounting

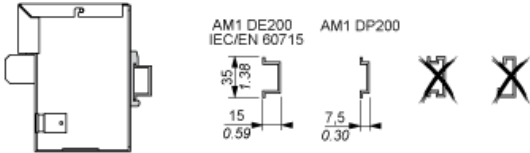

Wiring Requirements

Cable Types and Wire Sizes

	ABL 8BPK24A00 6 / 10	ABL 8BBU2400 10 / 6
Ø ≤ 4 mm ² Ø ≤ 12 AWG	Ø > 4 mm ² Ø > 12 AWG	
Ø 5,5 mm / 0.22 in	Nm 1,7 Nm max lb-in 15	

24 Vdc Battery Module Wiring

Wiring Diagram

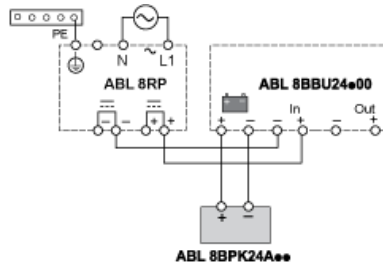

Paralleling 2 x ABL8BPK24A00

Wiring Diagram

