

SERIES 79A

Linear Action Circuit Selector

SERIES 79C

Linear Action Tap

FEATURES

- Single-Setting Programming
- Isolated or Bussed Circuits
- 10 or 16 Positions
- 125 mA, 6 Vdc, 2000 Cycles

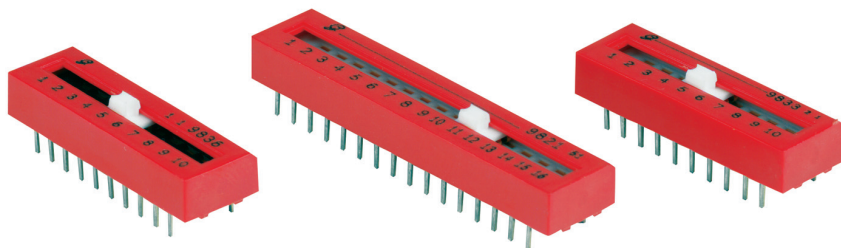

Circuit Selector

Isolated Circuits in 10 and 16 Positions

Each position is a single isolated circuit, which connects the two terminals across the switch package. The movable contact is non-shorting.

Tap Switch

SP/10 Positions, and SP/16 Positions

All contacts on one side of the switch are internally bussed for a common pole. Any terminal on that side may be used as a common, the others may be clipped. The movable contact is non-shorting.

DIMENSIONS In inches (and millimeters)

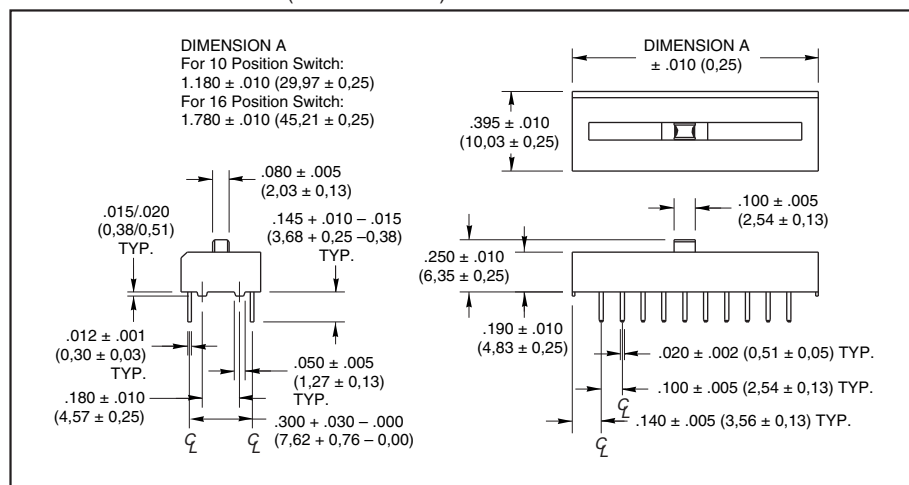

CIRCUITRY

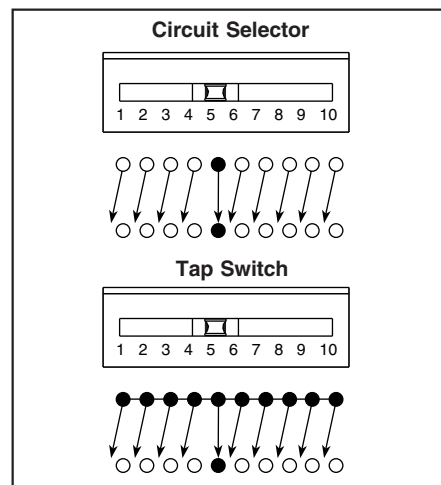

SPECIFICATIONS

Electrical Ratings

Make-and-break Current Rating: 2,000 cycles at 10 mA, 50 mVdc; 2,000 cycles at 125 mA, 6 Vdc; 2,000 cycles at 50 mA, 30 Vdc.

Contact Resistance: (measured at 10 mA, 50 mVdc) Coded Switches: 60 mohms maximum initially. Other Switches: 50 mohms maximum initially. After Life: 100 mohms maximum

Insulation Resistance (at 100 Vdc):

Between adjacent isolated contacts: Initial: 5,000 Mohms; 1,000 Mohms minimum after life. Across open contacts: Initial: 5,000 Mohms; 1,000 Mohms minimum after life.

Dielectric Strength: Between adjacent isolated contacts and also across open contacts. Initially: 750 Vac; 500 Vac after life

Contact Carry Rating: 2 Amps with a maximum contact temperature rise of 20°C

Mechanical Ratings

Mechanical Life: 4,000 cycles maximum. Note: a cycle is one complete operation, back and forth through all switch positions.

Vibration Resistance: 10 to 2,000 Hz at 15G or 0.060" double amplitude, per MIL-STD-202F per MIL-5-83504; Method 213, Condition A. No damage and no contact openings exceeding 10 mS (Method 204, Test Condition B).

Shock Resistance: 509, 11 mS, half sine; no damage and no openings exceeding 10 mS (Method 213, Test Condition A).

Environmental Rating

Operating Temperature Range: -40°C to +85°C

Storage Temperature Range: -55°C to +85°C
Moisture Resistance: 240 hours with temperature cycling and polarization, per MIL-STD-202F, Method 305

Materials and Finishes

Nonconductive Parts: Plastic UL94V-O

Shorting Arm: Phosphor bronze, gold plate over nickel plate

Base Contacts: Copper alloy, gold plate over nickel plate

Terminals: Copper alloy, matte tin plated over nickel barrier.

Potting Material: Epoxy

Tape and Seal Packaging

Seal Strength: Per MIL-STD-202, Method 112. 30 seconds at 125° hot Fluorocarbon

Solderability: Per MIL-STD-202, Method 208.

Tape Seal: Polyester film

Available from your local Grayhill Distributor.

For prices and discounts, contact a local Sales Office, an authorized local Distributor or Grayhill.

ORDERING INFORMATION

Number of Positions	Type of Circuit Code	Number per Tube	Part Number*
10	Circuit Selector	9	79A10T
10	Single Pole	9	79C10T
16	Circuit Selector	6	79A16T
16	Single Pole	6	79C16T

*A top tape seal is required for switches that are machine soldered or heavily cleaned after hand soldering. To order top seal versions, add "S" before the "T" in the Grayhill part number.