

LIQUID CRYSTAL DISPLAY MODULE
G 3 2 1 E V
USER'S MANUAL

Seiko Instruments Inc.

NOTICE

This manual describes the technical information, as well as the functions and operation of the G321EV Liquid Crystal Display Module made by Seiko Instruments Inc. Please read this manual carefully to familiarize yourself with the functions so you can make the best use of them.

The descriptions here are subject to change without notice.

Revision Record

<u>Edition</u>	<u>Revision</u>	<u>Date</u>
1	Original	June 1995

© Seiko Instruments Inc. 1995

Printed in Japan

CONTENTS

1. SPECIFICATIONS	
1.1 General	1
1.2 Features	1
1.3 Option Specifications	1
1.4 Absolute Maximum Ratings (excluding CFL backlight)	2
1.5 Mechanical Characteristics	2
1.6 Electrical Characteristics (excluding CFL backlight)	2
1.7 Optical Characteristics	3
1.8 LCD Panel Lifetime	4
1.9 Dimensions	5
2. CIRCUIT STRUCTURE	
2.1 Liquid Crystal Driving Circuit	6
2.2 Circuit Structure	8
2.3 Timing Characteristics	12
2.4 Interface Circuit	14
3. CFL BACKLIGHTING	
3.1 Absolute Maximum Ratings	18
3.2 Electrical Characteristics	18
3.3 Brightness	18
3.4 Service Life	19
3.5 Connector for CFL Backlight	19
3.6 Recommended CFL Inverter	19
3.7 CFL Backlight Replacement Procedures	23
4. NOTES	25
INDEX	

1. SPECIFICATIONS

1.1 General

The G321E is a thin liquid crystal display (LCD) module that consists of a full dot-matrix LCD panel, CMOS LSIs, and a CFL backlight. The LCD panel features a wide viewing angle and high contrast. The full dot-matrix structure allows both graphics and character display. In addition, the display is clear and stable, with no image warping or position skew, because the display position is specified by the intersection of transparent electrodes in a matrix.

1.2 Features

- Full dot-matrix structure with 320 × 240 dots
- 1/240 duty
- Four-bit parallel data input
- Two power supplies : $V_{DD} = 5\text{ V}$, $V_{LC} = -24\text{ V}$ (for driving liquid crystal)
- Built-in CFL backlighting, high-brightness, side-lighting type, using one CFL
- Easy replacement of the CFL
- Weight : Approx. 195 g

1.3 Option Specifications

Model name	LCD	Dot color*	Background color*	Viewing angle	
G321EV5R000	FSTN type (black and white)	White	Black	6 o'clock	Transmissive, with CFL backlighting (white), negative mode**
G321EV5B000	STN type (blue)	White	Blue	6 o'clock	Transmissive, with CFL backlighting (white), negative mode**

* The LCD colors are affected by temperature, so the colors at low or high temperature differ slightly from those in the above table.

** On a negative mode LCD, the dots are white when the display data is high, and black (G321EV5R000) or blue (G321EV5B000) when the display data is low. To get a positive display on a negative mode LCD, invert the display data before inputting it to the module.

1.4 Absolute Maximum Ratings (excluding CFL backlight)

$V_{SS} = 0\text{ V}$

Item	Symbol	Conditions	Min.	Max.	Unit
Power supply voltage	V_{DD}		0	6.0	V
	V_{LC}		$V_{DD} - 30.0$	V_{DD}	V
	V_O	$V_O \geq V_{LC}$	$V_{DD} - 30.0$	V_{DD}	V
Input voltage	V_{IN}		-0.3	$V_{DD} + 0.3$	V
Operating temperature	T_{opr}	$\leq 65\%RH$	0	+ 50	°C
Storage temperature	T_{stg}		-20	+ 60	°C
Storage humidity		$\leq 48\text{ hrs}$	+20	+85	%RH
		$\leq 1000\text{ hrs}$	+20	+65	%RH

1.5 Mechanical Characteristics

Item	Standard
Dot configuration	320 × 240 dots
Module dimensions (H × V × T) [mm]	150.0 × 96.0 × 14.0 max.
Viewing area (H × V) [mm]	103.0 × 80.0
Active display area (H × V) [mm]	95.97 × 71.97
Dot dimensions (H × V) [mm]	0.27 × 0.27
Dot pitch (H × V) [mm]	0.30 × 0.30
Weight [g]	195 typ.

H : Horizontal V : Vertical T : Thickness (max.)

1.6 Electrical Characteristics (Excluding CFL Backlight)

1.6.1 FSTN type (Black and white, transmissive type)

$V_{SS} = 0\text{ V}, T_a = 0^\circ\text{C to } 50^\circ\text{C}$

Item	Symbol	Conditions	Min.	Typ.	Max.	Unit
Power supply voltage	V_{DD}		4.75	5.00	5.25	V
	V_{LC}	$V_{DD} = 5\text{ V}$	-24.5	-24.0	-23.5	V
	V_O	$V_{DD} = 5\text{ V}$ $V_O \geq V_{LC}$	-23.0	—	-5.0	V
Input voltage	High	$V_{DD} = 5\text{ V} \pm 5\%$	$0.8 V_{DD}$	—	V_{DD}	V
	Low	$V_{DD} = 5\text{ V} \pm 5\%$	0	—	$0.2 V_{DD}$	V
Current consumption*	I_{DD}	$V_{DD} = 5.0\text{ V}, V_{LC} = -24.0\text{ V}$ $V_O = -15.6\text{ V}$	—	6.4	15	mA
	I_{LC}	$f_{FLM} = 70\text{ Hz}, T_a = 25^\circ\text{C}$	—	5.7	15	mA
Frame frequency	f_{FLM}	$V_{DD} = 5\text{ V} \pm 5\%$	66.5	70	73.5	Hz

* Display patterns : Checkered patterns
Display data shift clock frequency : 3.0 MHz

1.6.2 STN type (Blue, transmissive type)

 $V_{SS} = 0\text{ V}$, $T_a = 0^\circ\text{C}$ to 50°C

Item	Symbol	Conditions	Min.	Typ.	Max.	Unit	
Power supply voltage	V_{DD}		4.75	5.00	5.25	V	
	V_{LC}	$V_{DD} = 5\text{ V}$	-24.5	-24.0	-23.5	V	
	V_O	$V_{DD} = 5\text{ V}$ $V_O \geq V_{LC}$	-23.0	—	-5.0	V	
Input voltage	High	V_{IH}	$V_{DD} = 5\text{ V} \pm 5\%$	$0.8 V_{DD}$	—	V_{DD}	V
	Low	V_{IL}	$V_{DD} = 5\text{ V} \pm 5\%$	0	—	$0.2 V_{DD}$	V
Current consumption	I_{DD}	$V_{DD} = 5.0\text{ V}$, $V_{LC} = -24.0\text{ V}$ $V_O = -16.2\text{ V}$ $f_{FLM} = 70\text{ Hz}$, $T_a = 25^\circ\text{C}$	—	6.4	15	mA	
	I_{LC}		—	5.7	15	mA	
Frame frequency	f_{FRM}	$V_{DD} = 5\text{ V} \pm 5\%$	66.5	70	73.5	Hz	

* Display patterns : Checked patterns
Display data shift clock frequency : 3.0 MHz

1.7 Optical Characteristics

1.7.1 FSTN type (Black and white, transmissive type)

 $1/240$ duty, $1/13.1$ bias, $f_{FLM} = 70\text{ Hz}$, $V_{opr} = V_{DD} - V_O$, CFL backlight: ON

Item	Symbol	Conditions	Temp.	Min.	Typ.	Max.	Unit	Reference
Viewing angle	θ_1	$C \geq 2.0$ $\varnothing = 0^\circ$ $V_{opr} = 20.6\text{ V}$	25°C	—	—	-20	deg.	Notes 1 and 2
	θ_2			50	—	—		
	$\theta_2 - \theta_1$			70	—	—		
Contrast	C	$\theta = -10^\circ$ $\varnothing = 0^\circ$ $V_{opr} = 20.6\text{ V}$	25°C	5.0	8.0	—	—	Note 3
Response time (rise)	t_{on}	$\theta = 0^\circ$ $\varnothing = 0^\circ$ $V_{opr} = 20.6\text{ V}$	25°C	—	230	350	ms	Note 4
Response time (fall)	t_{off}			—	150	230		
Response time (rise)	t_{on}	$\theta = 0^\circ$ $\varnothing = 0^\circ$ $V_{opr} = 22.4\text{ V}$	0°C	—	1100	1700		
Response time (fall)	t_{off}			—	500	750		

Measuring instrument : Canon illuminometer LC-35

1.7.2 STN type (Blue, transmissive type)

 $1/240$ duty, $1/13.1$ bias, $f_{FLM} = 70\text{ Hz}$, $V_{opr} = V_{DD} - V_O$, CFL Backlight : ON

Item	Symbol	Conditions	Temp.	Min.	Typ.	Max.	Unit	Reference
Viewing angle	θ_1	$C \geq 2.0$ $\varnothing = 0^\circ$ $V_{opr} = 21.2\text{ V}$	25°C	—	—	-15	deg.	Notes 1 and 2
	θ_2			20	—	—		
	$\theta_2 - \theta_1$			35	—	—		
Contrast	C	$\theta = 0^\circ$ $\varnothing = 0^\circ$ $V_{opr} = 21.2\text{ V}$	25°C	2.0	3.0	—	—	Note 3
Response time (rise)	t_{on}	$\theta = 0^\circ$ $\varnothing = 0^\circ$ $V_{opr} = 21.2\text{ V}$	25°C	—	170	260	ms	Note 4
Response time (fall)	t_{off}			—	190	290		
Response time (rise)	t_{on}	$\theta = 0^\circ$ $\varnothing = 0^\circ$ $V_{opr} = 22.8\text{ V}$	0°C	—	1100	1700		
Response time (fall)	t_{off}			—	500	750		

Measuring instrument : Canon illuminometer LC-35

Note 1 : Definition of angles θ and ϕ

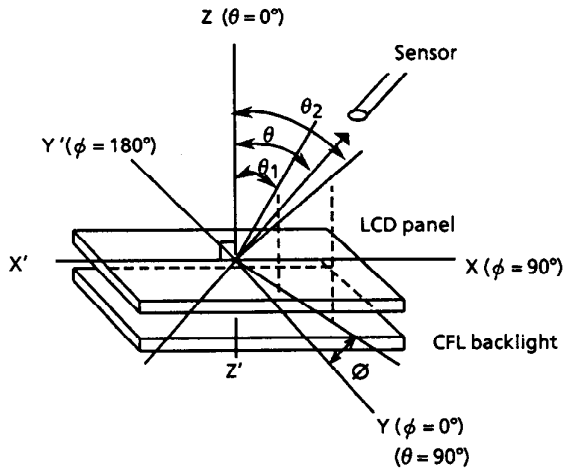

Note 2 : Definition of viewing angles θ_1 and θ_2

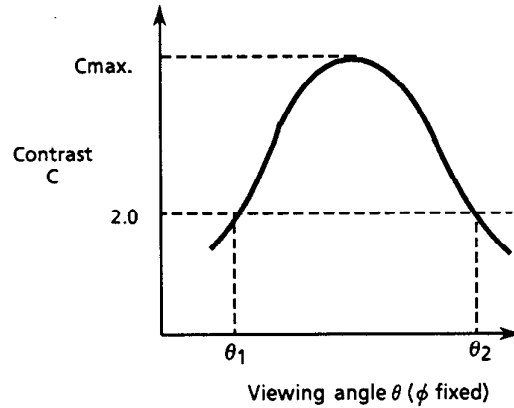

Note : Optimum viewing angle with the naked eye and viewing angle θ at C_{max} . above are not always the same.

Note 3 : Definition of contrast C

$$C = \frac{\text{Brightness of selected dot } (B_2)}{\text{Brightness of unselected dot } (B_1)}$$

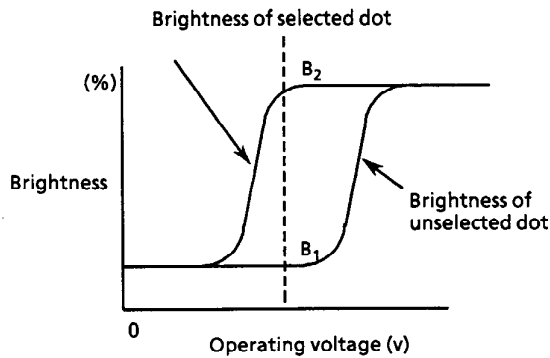

Note 4 : Definition of response time

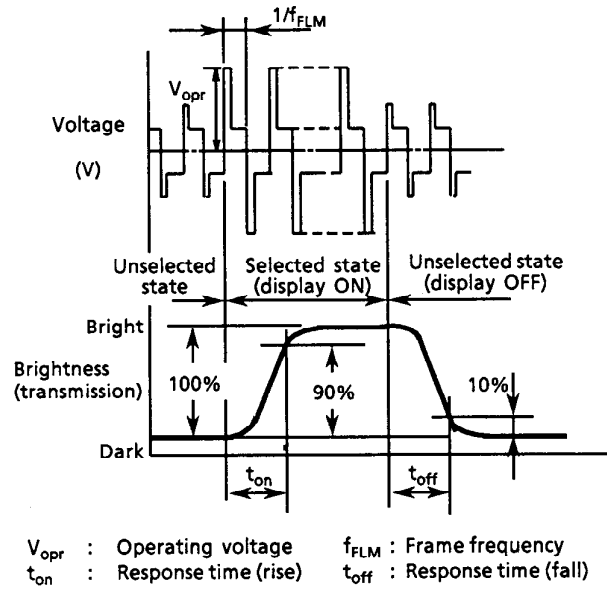

V_{opr} : Operating voltage f_{FLM} : Frame frequency
 t_{on} : Response time (rise) t_{off} : Response time (fall)

1.8 LCD Panel Lifetime

Item	Conditions	Standard	Unit
Lifetime*	25°C ± 10°C < 65% RH	100,000 or more	hrs

- * Definition of lifetime : the time up to occurrence of any of the following :
- Contrast reduces to 30% of the initial value.
 - Current consumption becomes three times the initial value.
 - Orientation deteriorates significantly.
 - The display malfunctions.

1.9 Dimensions

[I/O Terminal Functions]
CN1

Figure 1 Dimensions

No.	Symbol	Function	No.	Symbol	Function
1	FLM	One-frame timing signal	8	D ₂	Display data input
2	M	NC (or liquid crystal AC drive control signal)	9	D ₃	Display data input
3	CL1	One-common-line timing signal	10	V _{DD}	Power supply voltage (1): + 5 V
4	CL2	Display data shift clock	11	V _{SS}	GND: 0 V
5	$\overline{\text{DISPOFF}}$	Display ON/OFF control terminal**	12	V _{LC}	Power supply voltage (2) : - 24 V
6	D ₀	Display data input	13	V _O	Liquid crystal drive voltage adjustment terminal
7	D ₁	Display data input	14	F _{GND}	Frame ground*

* The F_{GND} terminal is connected to the module metal frame.
Use this terminal to ground the frame.

** The display is on when $\overline{\text{DISPOFF}}$ is H, and off when L.

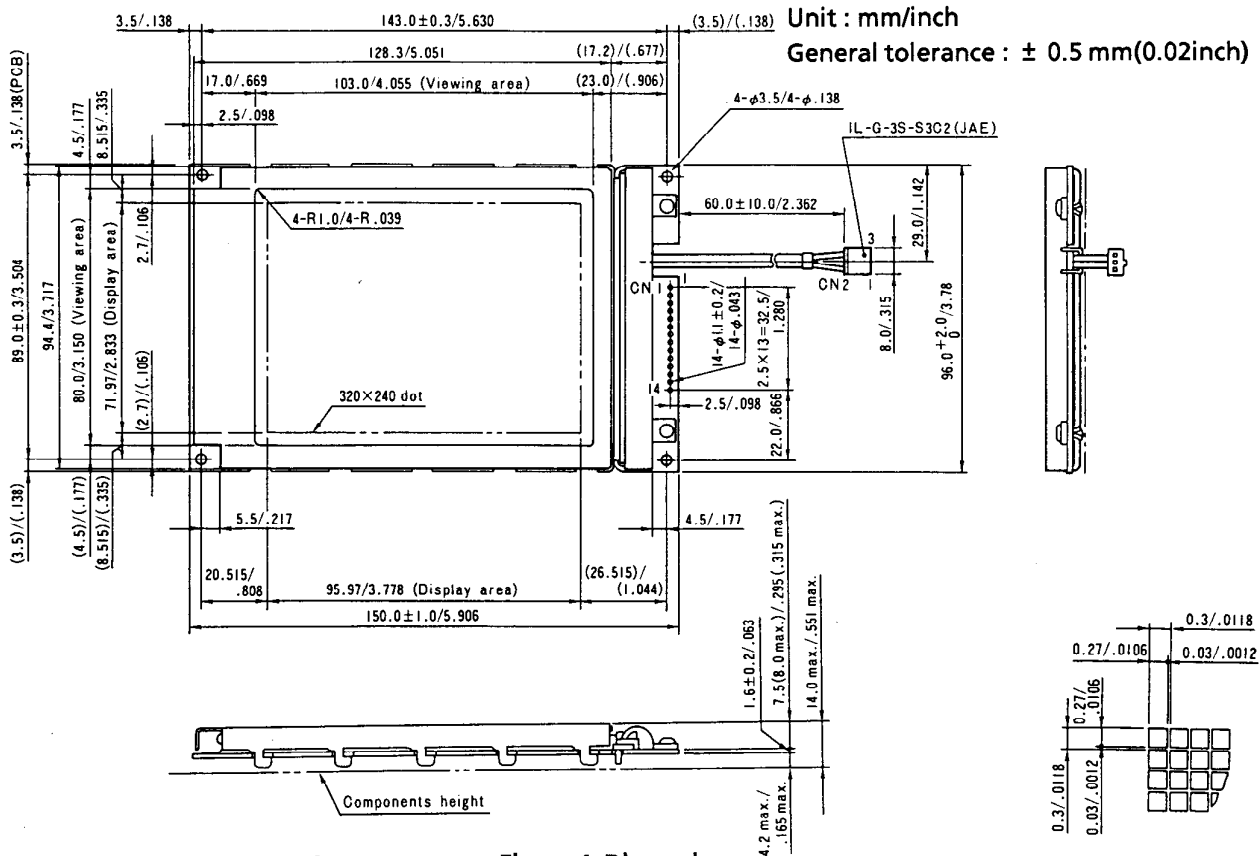
CN2

CFL connector: socket IL-G-3S-S3C2 (JAE), socket contact IL-G-C2-SC-10000 (JAE)

Mating connector (board mount type): IP-G-3P-S3T2-E (straight type) (JAE)

IL-G-3P-S3L2-E (right-angle type) (JAE)

No.	Symbol	Wire color	Function
1	V _{FL}	black	GND*: 0 V
2	NC	—	NC
3	V _{FL1}	Red	CFL backlight drive signal

* Not connected to V_{SS} (GND) of CN1.

2. CIRCUIT STRUCTURE

2.1 Liquid Crystal Driving Circuit

The G321E LCD panel drive waveform is shown in Figure 2. Since DC voltage will damage the liquid crystal, AC voltage is applied between the two frames. The signal controlling this is the liquid crystal AC drive control signal *M*.

Depending on the LCD panels, increasing the liquid crystal AC drive waveform frequency may improve the display quality. The G321E contains a circuit that generates AC drive control signal *M'*, which has a higher frequency than that of *M*. The frequency of the *M'* signal is adjusted according to the LCD panel to provide the best display quality. The use of an external *M* signal is also possible if necessary.

The liquid crystal driving circuit using an *M'* signal does not require an *M* signal to be input. However, the interface circuit should be provided with *M* signal input for compatibility with the liquid crystal driving circuit using a *M* signal.

The frame frequency is normally set to 70Hz \pm 5% to prevent screen flicker.

The G321E has a 1/240 duty cycle, and the common electrodes are selected within a frame by time division from electrode 1 to electrode 240. This is called line sequential scanning. The voltage level of the segment electrodes determines whether or not the dots at the intersection of the segment electrodes are selected when the common electrode is selected. As shown in Table 1, there are six drive waveform voltage levels, *V_a* to *V_f*. The voltage level is determined by the bias value. The voltage between the segment and common electrodes is then applied to the liquid crystal. The selection waveform for SEG0-COM0 and the non-selection waveform for SEG1-COM1 are shown in Figure 2. The size of the effective voltage of the waveform determines whether the liquid crystal under the selected dots is in the selection or non-selection state.

Table 1

<i>V_a</i>	Common and segment selection level
<i>V_b</i>	Common non-selection level
<i>V_c</i>	Segment non-selection level
<i>V_d</i>	Segment non-selection level
<i>V_e</i>	Common non-selection level
<i>V_f</i>	Common and segment selection level

In black-and-white negative mode, the dot is white when the display data is "1" and black when "0". In blue negative mode, the dot is white when the display data is "1" and blue when "0".

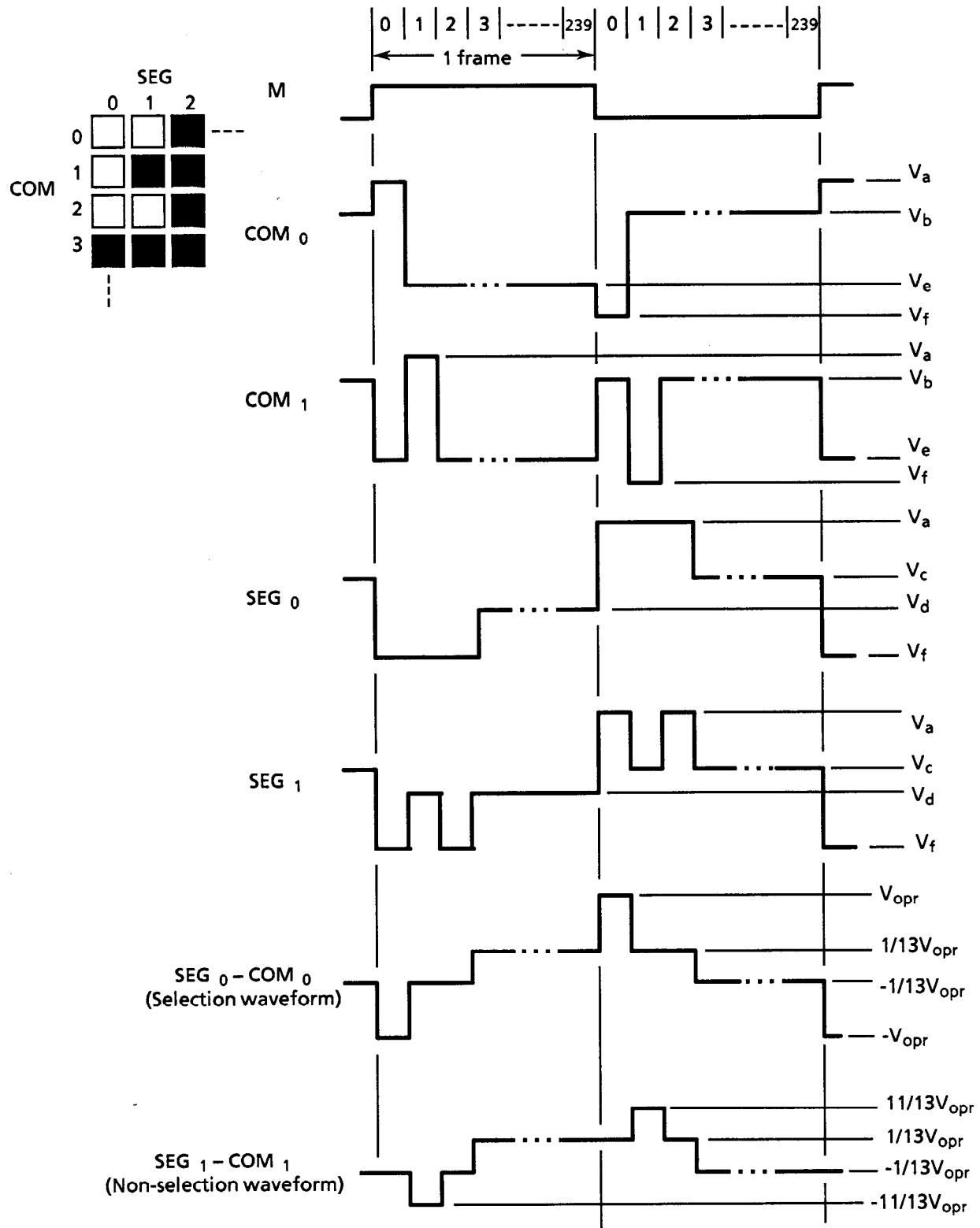

Figure 2 Drive Waveform

2.2 Circuit Structure

The G321E consists of common drivers, segment drivers, a bias voltage generation circuit, an M' generation circuit and a V_{opr} control circuit. Figure 3 shows the block diagram for the G321E. When an M signal is used instead of an M' signal, the M signal is directly input to the segment drivers and the common drivers.

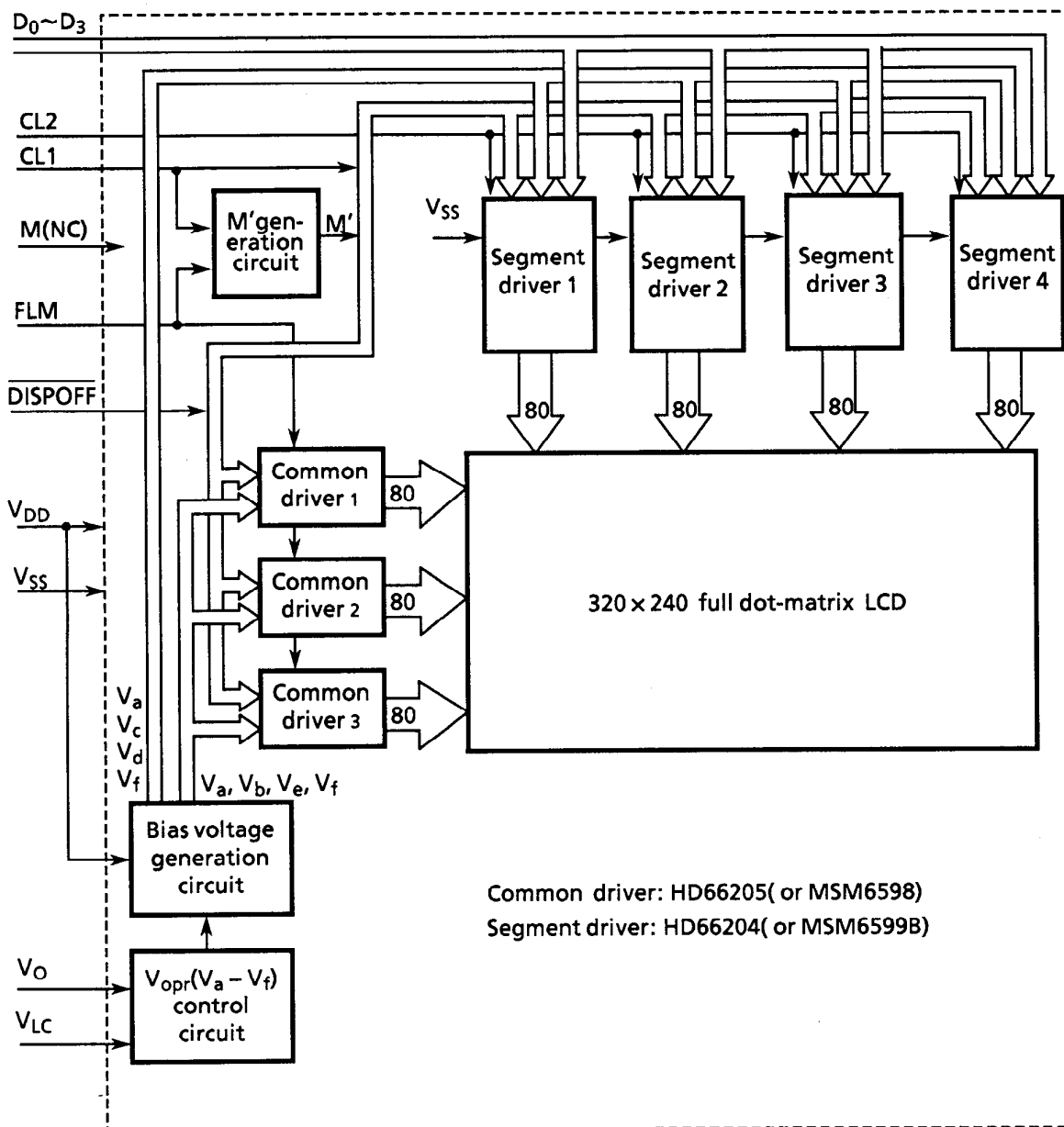

Figure 3 Block Diagram for G321E

(1) Common driver (HITACHI HD66205 or OKI MSM6598)

A common driver (CD) is a CMOS IC with 80 drive outputs. The G321E has three CDs, whose internal registers are connected to each other. They operate as follows.

Input one-frame timing signal (FLM) is taken into the internal shift register by the falling edge trigger of the one-common-line timing signal (CL1), and sequentially shifted. After 240-CL1 input, the next FLM is input and the same operation is repeated. As shown in Table 2, the common output is selected according to the shift register contents and the internally-generated liquid crystal AC drive control signal (M') in the drive circuit, and the common drive waveform are formed.

Table 2

$\overline{\text{DISPOFF}}$	Shift register content	M'	COM output
H	H	H	V_a
		L	V_f
	L	H	V_e
		L	V_b
L	X	X	V_a

x: Invalid

The common output is controlled by the $\overline{\text{DISPOFF}}$ signal; when the $\overline{\text{DISPOFF}}$ signal is low, the common output is V_a , irrespective of the shift register contents or the M' signal.

(2) Segment driver (HITACHI HD66204 or OKI MSM6599B)

A segment driver (SD) is a CMOS IC with 80 drive outputs. The G321E has four SDs, which operate as follows.

Input four-bit data is sequentially taken into the internal register by the falling edge trigger of the display data shift clock (CL2). The SDs have a chip enable function. After 80 bits of data are taken into SD1, the next bit of data is automatically taken into SD2. Since G321E has four SDs, 320 bits of data can be taken. The display data taken into the internal register are latched by the falling edge trigger of CL1. The segment output is selected according to this display data and M' in the drive circuit, and the segment drive waveform is formed as shown in the Table 3.

Table 3

$\overline{\text{DISPOFF}}$	Display data	M'	SEG output
H	H	H	V_f
		L	V_a
	L	H	V_d
		L	V_c
L	X	X	V_a

x: Invalid

The segment output is controlled by the $\overline{\text{DISPOFF}}$ signal. When the $\overline{\text{DISPOFF}}$ signal is low, V_a is output to the segment, irrespective of the display data and of the M' signal. Therefore, by bringing the $\overline{\text{DISPOFF}}$ signal to low, V_a is output both to the common and to the segment electrodes, making the voltage applied to the liquid crystal zero, and the display goes off.

The relationship between the display data and display screen is shown below..

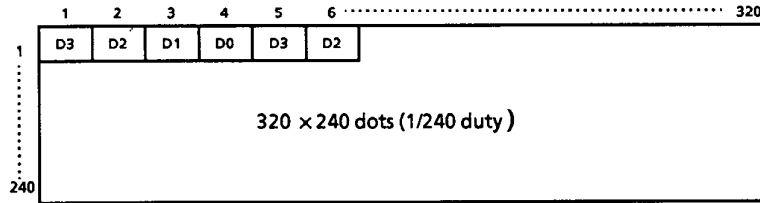

Figure 4

(3) V_{opr} control circuit

Display screen contrast and viewing angle are affected by changes in the liquid crystal operating voltage (V_{opr}). As shown in Figure 5, external V_{LC} is supplied to the operational amplifier and V_{opr} (V_a to V_f) is generated and applied to the LCD panel.

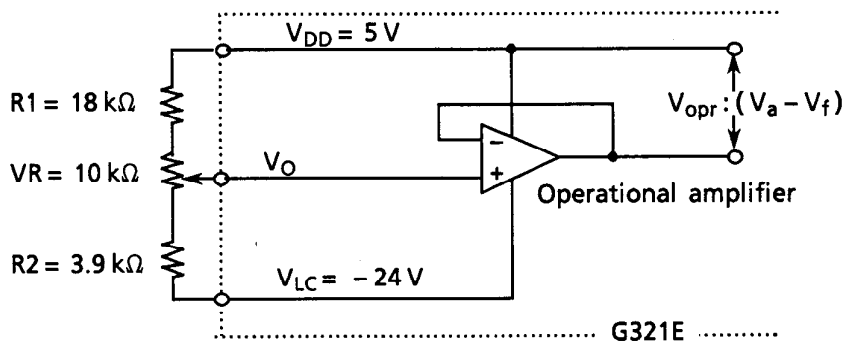

Figure 5

Also, display screen contrast and viewing angle are influenced by the ambient temperature. The recommended V_{opr} level at different temperatures is as follows.

Temperature (°C)		0	25	50
V_{opr} (V)*	FSTN (Black and white)	22.4	20.6	19.0
	STN (Blue)	22.8	21.2	19.7

* $V_{opr} \approx V_{DD} - V_O$

(4) Bias voltage generation circuit

Six voltage levels, V_a to V_f , are applied to the common and segment drivers. The voltage is generated through operational amplifiers by resistance division from the liquid crystal operating voltage (V_{opr}). Here, an operational amplifier is used as a voltage follower.

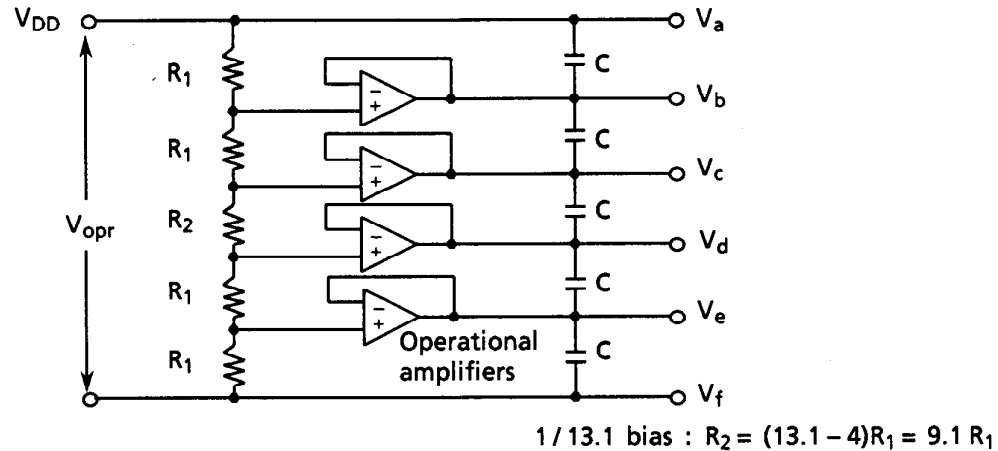
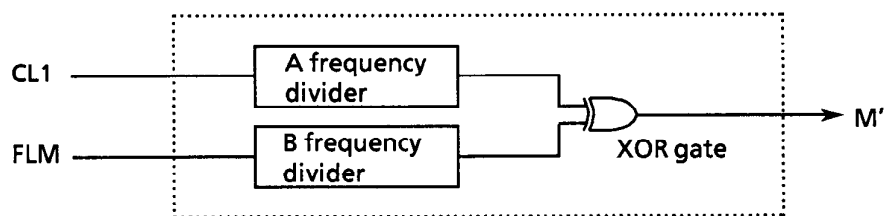

Figure 6 Bias Voltage Generation Circuit

(5) M' generation circuit

As Figure 7 shows, the M' generation circuit performs an XOR on the one-common-line timing signal (CL1) (on which A time division is performed) and the one-frame timing signal (FLM) (on which B time division is performed), and outputs liquid crystal AC drive control signal M' . Values A and B are set according to the LCD panel so that the best display quality can be obtained and the drive voltage can be changed.

Figure 7 M' Generation Circuit

2.3 Timing Characteristics

2.3.1 Power ON/OFF and Signal Input Timing

Power ON/OFF and signal input should be performed according to the timing shown in the figure below in order not to damage the LCD driving circuit and the LCD panel.

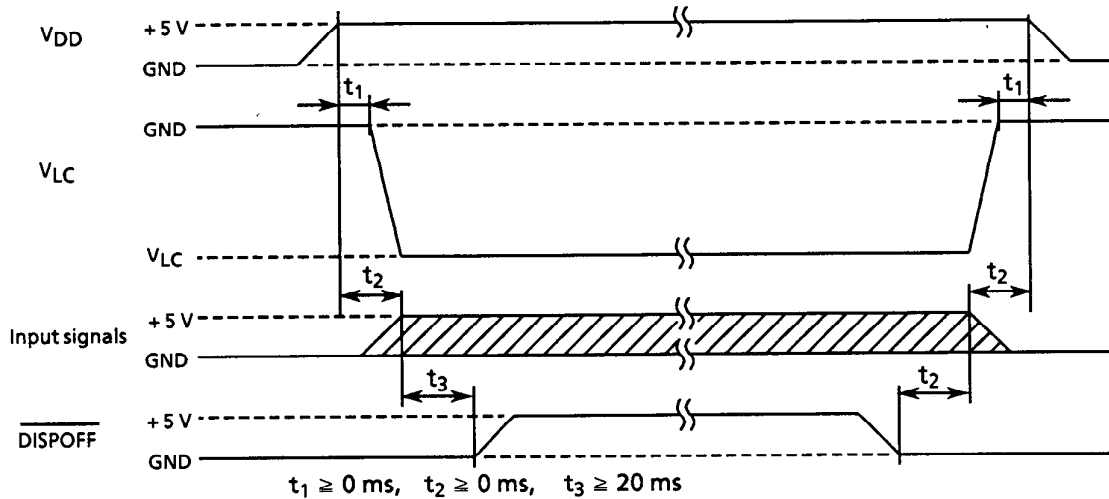

Figure 8 Power ON/OFF and Signal Input Timing

2.3.2 Timing Characteristics

Ta = 0°C to 50°C V_{DD} = 5.0V ± 5% V_{SS} = 0V

Item	Symbol	Min.	Typ.	Max.	Unit
FLM cycle time	t _{CFLM}	13.6	14.3	15.0	ms
CL1 cycle time	t _{CCL1}	10	59.6	—	μs
CL1 high level width	t _{WCL1H}	50	—	—	ns
CL1 low level width	t _{WCL1L}	1000	—	—	ns
FLM setup time	t _{FLMS}	100	—	—	ns
FLM hold time	t _{FLMH}	100	—	—	ns
CL1, CL2 rise time	t _R	—	—	30	ns
CL1, CL2 fall time	t _F	—	—	30	ns
CL2 cycle time	t _{CCL2}	125	—	—	ns
CL2 high level width	t _{WCL2H}	45	—	—	ns
CL2 low level width	t _{WCL2L}	45	—	—	ns
CL2 setup time	t _{DS}	20	—	—	ns
CL2 hold time	t _{DH}	20	—	—	ns
CL2 rise to CL1 rise	t _{LD}	—	—	—	ns
CL2 fall to CL1 fall	t _{SL}	80	—	—	ns
CL1 rise to CL2 rise	t _{LS}	—	—	—	ns
CL1 fall to CL2 fall	t _{LH}	80	—	—	ns

Timing Chart 1: Timing of Signal Input Into Common Driver

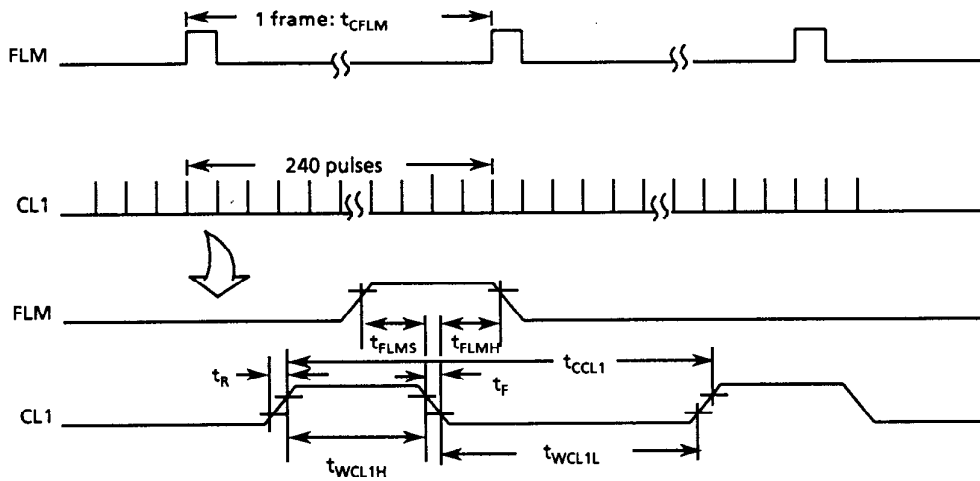

Figure 9

Timing Chart 2: Timing of Signal Input Into Segment Driver

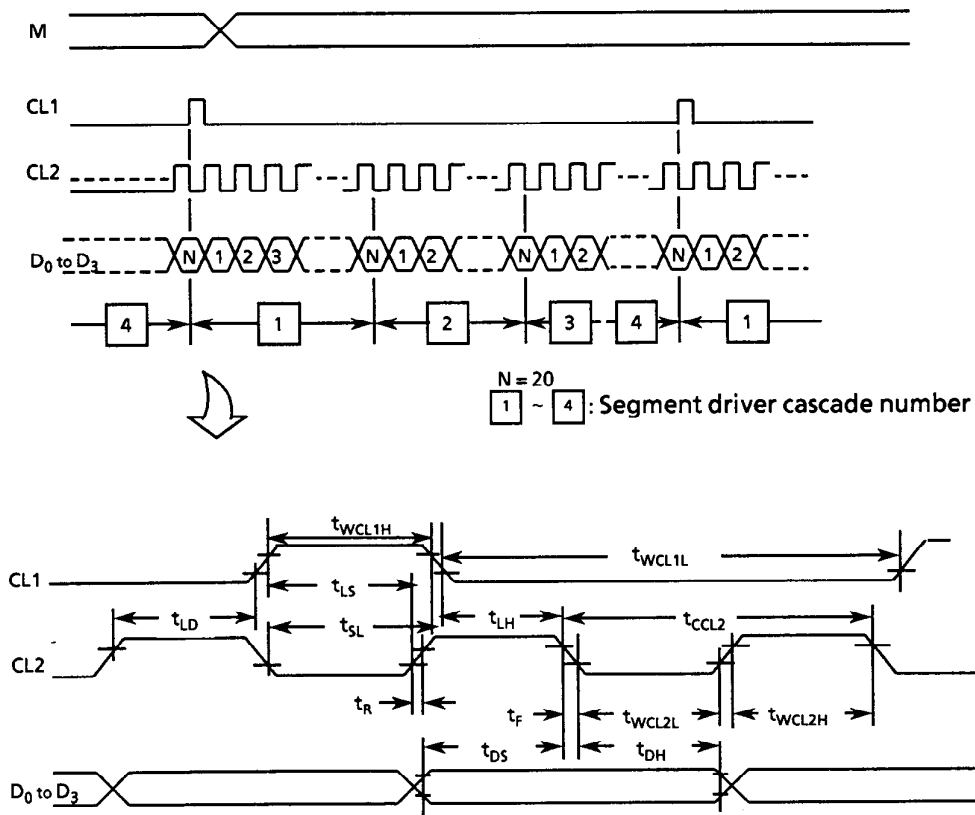

Figure 10

2.4 Interface Circuit

2.4.1 Interface with MPU signal

The G321E is controlled by the MPU circuit, whose interface is easily set up when the LCD controller is used. The LCD controller has basic functions such as receiving information related to the display from the MPU circuit, sending display timing signals and display data to the LCD module, as well as other functions such as cursor display.

The G321E must use an LCD controller conforming to the following:

- For a full dot-matrix LCD module
- Where data is transferred to the LCD module in four-bit parallel
- Where G321E display screen has 1/240 duty

The following section gives examples of interfaces using the Oki MSM6255GSK, Seiko Epson SED1330F, and Hitachi HD64646FS controllers.

(1) OKI MSM6255GSK

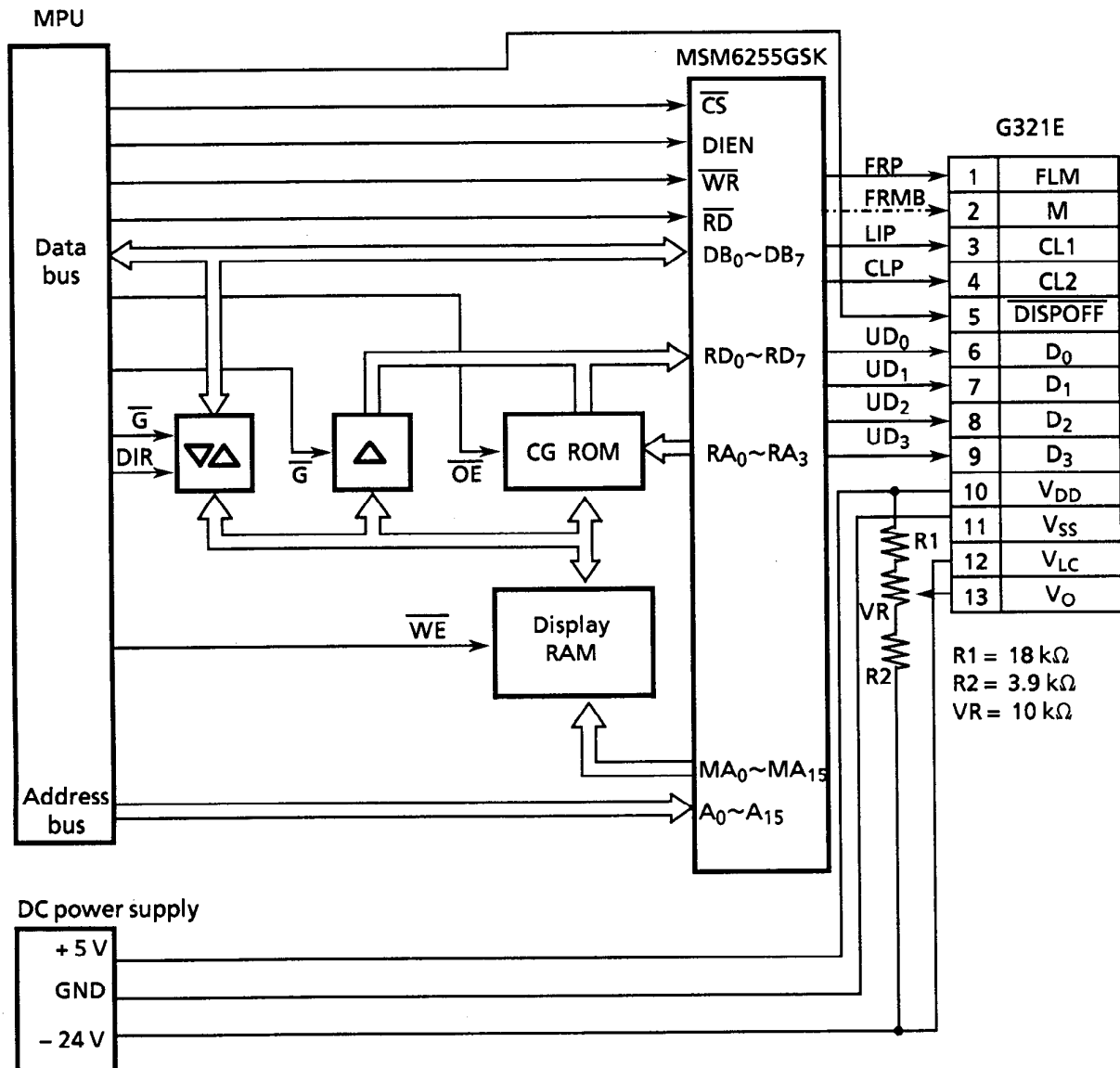

Figure 11 Interface Circuit With MSM6255GSK

Features of the MSM6255GSK:

- Interface with 80-series MPU possible
- Cursor
 - ON/OFF
 - Blinking speed, form, and position are programmable
- Scrolling and paging
- CMOS process
- 5-V single power supply

(2) SEIKO EPSON SED1330F

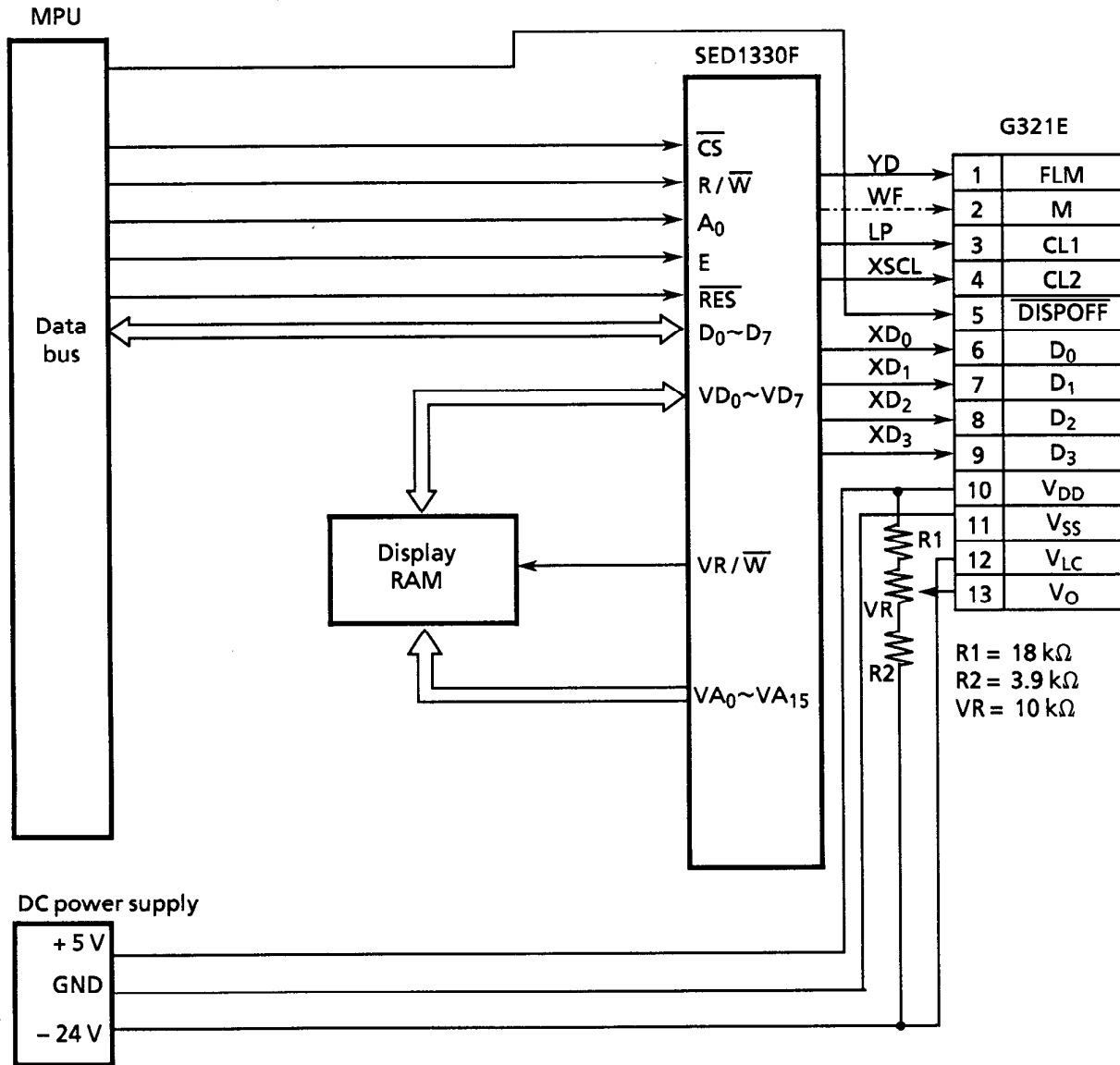

Figure 12 Interface Circuit With SED1330F

Features of the SED1330F:

- Interface with 80-series or 68-series MPU possible
- Built-in character generator ROM: 160 kinds
- External character generator
 - CG RAM : (8 × 16 dot matrix) × 64 kinds
 - CG ROM : (8 × 16 dot matrix) × 256 kinds
- Layered mode : AND, OR, XOR, "preferred" OR
- CMOS process
- Scrolling (vertical and horizontal)
- 5-V single power supply

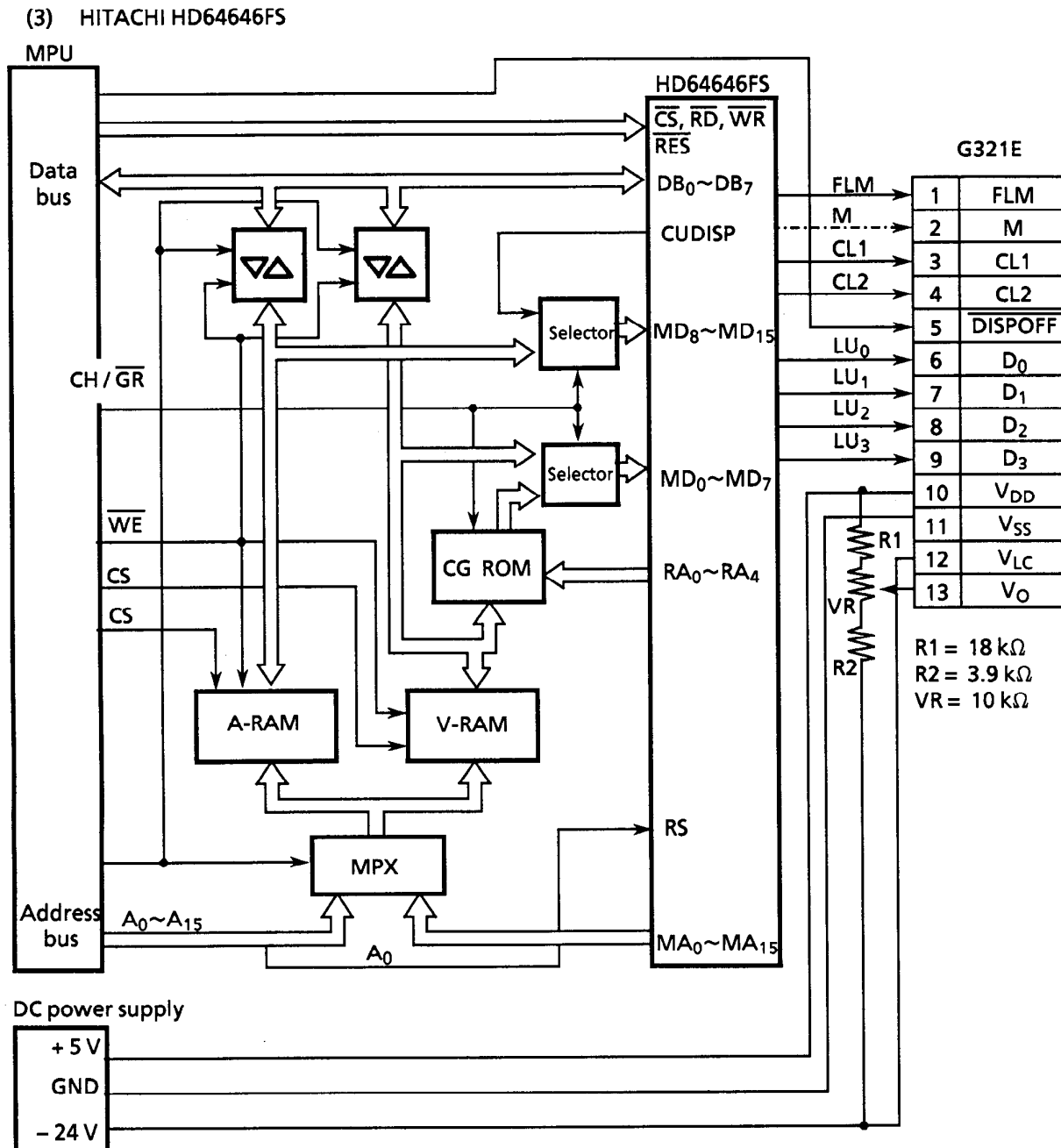

Figure 13 Interface Circuit With HD64646FS

Features of the HD64646FS:

- Interface with 80-series MPU possible
- Layered mode : OR (character and graphics)
- Character reverse, blinking, all black, all white
- Cursor
 - ON/OFF
 - Blinking speed, form and position are programmable
- Character font
 - Vertical : 1 to 32 dots
 - Horizontal : 8 dots
- Scrolling
 - Vertical : smooth or character unit
 - Horizontal : character unit
- CMOS process
- 5-V single power supply

3. CFL BACKLIGHTING

The G321E has a built-in CFL (cold cathode fluorescent lamp) backlight. A CFL inverter is not built in, so use the recommended CFL inverter.

3.1 Absolute Maximum Ratings

Ta = 25°C

Item	Symbol	Rating	Unit
Circuit voltage	V _S	2000 max.	V rms
Lamp current	I _{FL}	10 max.	mA rms
Frequency	f _{FL}	100 max.	kHz

3.2 Electrical Characteristics

Item	Symbol	Conditions	Standard			Unit
			min.	typ.	max.	
Lamp voltage*	V _{FL}	Ta = 25°C	240	270	300	V rms
Lamp current*	I _{FL}	Ta = 25°C	2.8	3.1	3.4	mA rms
Frequency*	f _{FL}	Ta = 25°C	41	47	53	kHz
Starting voltage**	V _S	Ta = 0°C	-	-	650	V rms

* CFL inverter : INVC 303 (HITACHI)

Inverter input voltage : V_{IN} = 24.0 V

** With the rise in voltage between the CFL terminals, the glow discharge is generated at the CFL electrodes, and CFL lights as this discharge grows. The starting voltage is the voltage at which the light has become stable and maintainable.

3.3 Brightness

Brightness and the starting voltage of CFL change according to the ambient temperature. This is because the radiation efficiency of the mercury in the CFL lamp varies depending on the vapor pressure. Particularly, the brightness decreases at low temperatures. Brightness is also low immediately after CFL power-on, since the vapor pressure of the mercury is low. Brightness increases gradually with increasing mercury vapor pressure, as the CFL lamp generates heat and thus the lamp wall temperature rises.

Item	Symbol	Conditions	LCD	Standard			Unit
				min.	typ.	max.	
Brightness* (At the center of the LCD surface)	Bp	Ta = 25°C ± 3°C 30% to 85% RH 30 min. after CFL power ON	FSTN type (black and white)	50	90	-	cd / m ²
			STN type (blue)	100	130	-	

* CFL inverter : INVC303 (HITACHI)

Inverter input voltage : V_{IN} = 24.0 V

LCD driving conditions : optimum Vopr, f_{FLM} = 70 Hz

LCD display pattern : All ON display (All data = "H")

3.4 Service Life

Item	Conditions	Rating	Unit
Service life *	Ta = 25°C ± 3°C	10,000 min.	h

* Time until the brightness decreases to half of the initial brightness, or time until the CFL is not lit because of the increase in CFL starting voltage.
CFL driving conditions : I_{FL} = 3.1 mA rms

3.5 Connector for CFL Backlight

Connector for CFL backlight: Socket IL-G-3S-S3C2 (JAE)
Contacts IL-G-C2-SC-10000 (JAE)

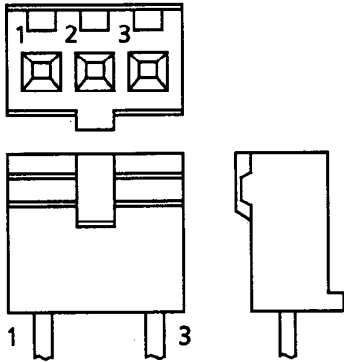

No.	Signal	Wire color	Functions
1	V _{FL}	Black	Ground* : 0 V
2	NC	–	NC
3	V _{FL1}	Red	CFL backlight drive signal I _{FL} = 3.1 mA rms, f _{FL} = 47 kHz

* Not connected to the LCD driver ground

Figure 14

3.6 Recommended CFL Inverter

3.6.1 Model name

INVC303 (HITACHI)

3.6.2 Absolute maximum ratings

Item	Symbol	Conditions	Standard		Unit
			min.	max.	
Power supply voltage	V _{IN}	Ta = 0°C to 50°C, GND = 0 V 20% RH to 85% RH	0	26.4	V
Operating temperature	Topr	No freezing or condensation	0	50	°C
Storage temperature	Tstg	No freezing or condensation	– 20	60	°C
Operating humidity	Hopr	No freezing or condensation	30	65	%RH
Storage humidity	Hstg	No freezing or condensation	20	85	%RH

3.6.3 Electrical characteristics

Ta = 25°C

Item	Symbol	Conditions	Standard			Unit
			min.	typ.	max.	
Power supply voltage	V _{IN}		21.6	24.0	26.4	V
Power supply current*1	I _{IN}	V _{IN} = 24.0 V	-	60	70	mA
Input current*1	I _{CONT}	CFL : ON	1.3	1.5	1.7	mA
No load output voltage*2	V _O	V _{IN} = 24.0 V	-	1000	-	V rms
Output current*1	I _{FL}	V _{IN} = 24.0 V	2.8	3.1	3.4	mA rms
Oscillation frequency*1	f _{FL}	V _{IN} = 24.0 V	41	47	53	kHz
Starting characteristics at low temperature		V _{IN} = 24.0 V, Ta = 0°C Load : CFL backlight unit BL-5/ASD(HITACHI)	-	-	2	sec.

*1 Measurement circuit 1

*2 Measurement circuit 2

(1) Measurement circuit 1

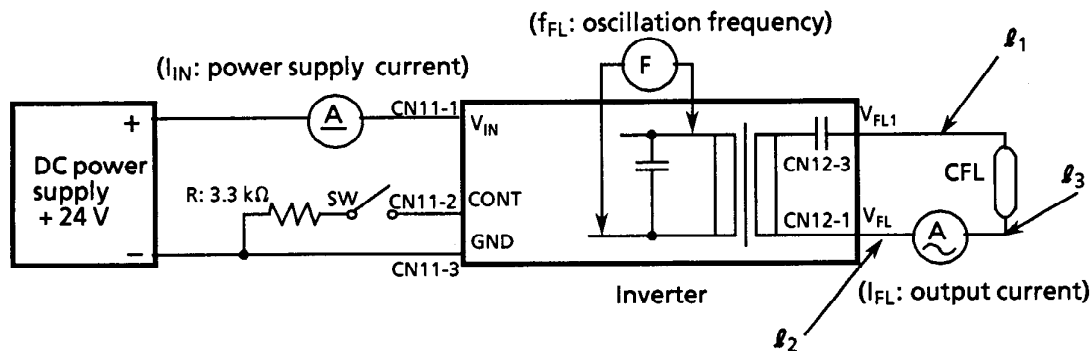

· Measuring conditions

- ① Load: CFL03-88EX57G/L(tube) for G321EV
- ② Output lead wires
 - Type: UL1015
 - Length: $l_1 = 200$ mm, $l_2 + l_3 = 200$ mm
 - Connection : Lead wires should be connected to the CFL without being bound as shown above.
- ③ CN11-2 terminal: GND: CFL is on, OPEN: CFL is off

· Measuring instruments

- ① Power supply current: Digital voltmeter TR-6853(TAKEDA RIKEN) or equivalent
- ② Output current: High-frequency AC ammeter 2016 class 1.0 (YEW) or equivalent
- ③ Oscillation frequency: Multicounter 255(KIKUSUI) or equivalent

Figure 15 Measurement Circuit 1

(2) Measurement circuit 2

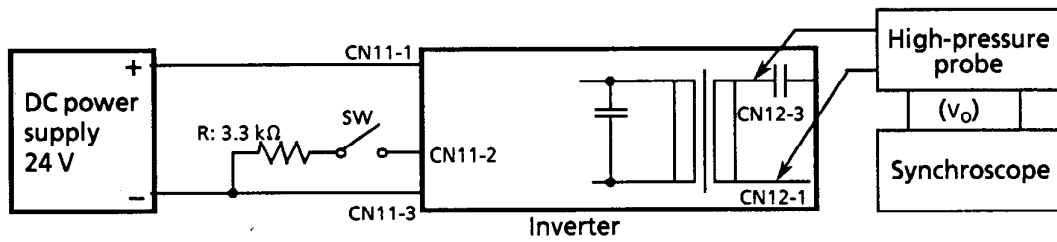

· Measuring instruments

- ① No load output voltage: Synchroscope: IWATSU DS-6121A or equivalent
High-pressure probe: IWATSU HV-P30 or equivalent

Figure 16 Measurement Circuit 2

3.6.4 Temperature of transformer

Item	Conditions	Standard			Unit
		min.	typ.	max.	
Temperature of transformer	T _a = 50°C, V _{IN} = 24 V	-	-	95	°C

3.6.5 Inverter connection diagram (INVC303)

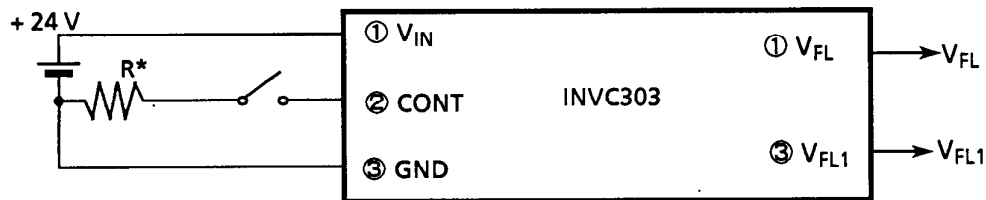

- * Connect a current-limiting resistor.
I_{CONT}: 1.3 mA to 1.7 mA (1.5 mA typ.)

Figure 17 Inverter Connection Diagram

3.6.6 Backlight ON/OFF control

The ON and OFF of the backlight is controlled using CONT pin; the backlight is on when CONT pin is connected to GND and off when CONT pin is open.

3.6.7 Dimensions

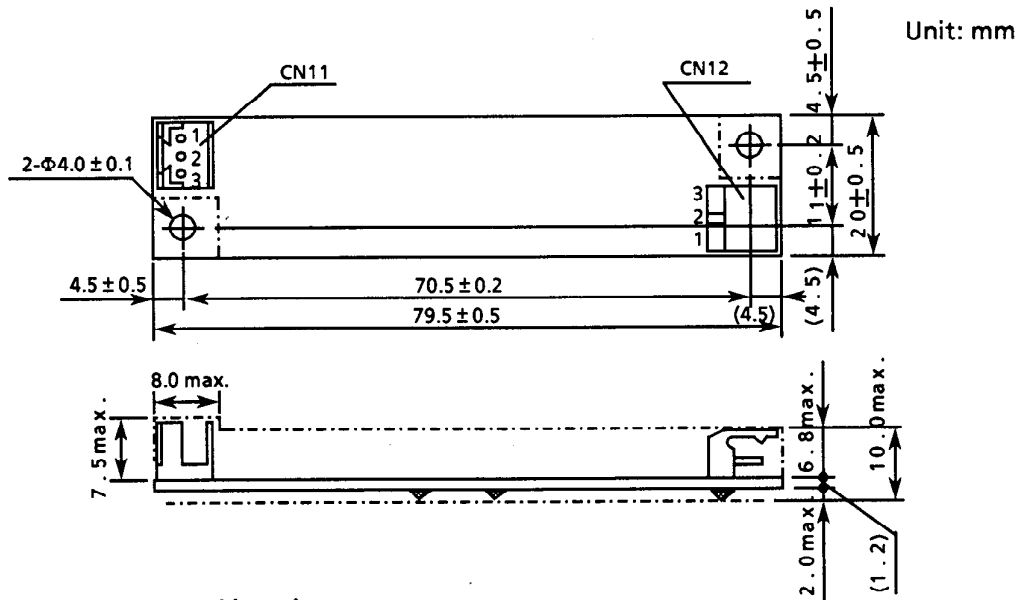

CN 11 : 175487-3(AMP)
Mating connector : 173977-3(AMP)

Pin No.	Signals	Functions
1	V _{IN}	Power supply voltage: + 24 V
2	CONT	Backlight on/off control ON: GND, OFF: OPEN
3	GND	Ground: 0 V

CN 12 : IL-G-3P-S3L2-E(JAE)

Pin No.	Signals	Functions
1	V _{FL}	Output: GND
2	NC	—
3	V _{FL1}	Output: high voltage

Figure 18

3.6.8 Precautions in using the inverter

- (1) As the output of the inverter is high voltage, never touch it.
- (2) When connecting the inverter to the CFL, the following must be considered to avoid stray capacity effects:
 - Do not twist together or tie the CFL connector cables.
 - Metal plates and metal foils, if located close to the CFL and its wiring, affect the brightness and the starting voltage of the CFL.
 - Connect the CFL connector directly to the inverter output connector. Do not use an extension cable.
 - Be aware of the proximity of other parts and the casing to the secondary wiring of the inverter, the potential of these parts may significantly affect the electrical characteristics and startability of the inverter.

- (3) The transformer mounted on the inverter gets very hot; therefore, do not use the inverter in a closed, small space.
- (4) Always use AWG No.26 or thicker wire on the input side of the inverter.
- (5) Make sure that the fluctuating load caused by use of the inverter does not turn into a fluctuation of voltage and affect the other circuits.

3.7 CFL Backlight Replacement Procedures

The G321EV backlight is structured so that the lamp holder and the light guide can be divided, making it possible for the lamp holder with a built-in lamp to be replaced without disassembling the module.

The CFL backlight replacement procedures are as follows:

CAUTION: Always turn off the power before replacing any parts because the inverter operates at high voltage. Also do not force any of the parts around the base of the lamp cable when moving it. While holding the mold of the lamp cable at the base with your finger, loosen and adjust the other the parts.

- (1) Turn off the power.
- (2) Remove the lamp cable from the backlight power supply of the inverter.
- (3) Loosen the cable that is secured by the hook on the lamp holder.
- (4) Remove the two plastic rivets that secure the lamp holder to the circuit board. Push on the tip of the rivets to loosen them, and then pull them out. Because the rivets are made up of two pieces that come apart when you remove them from the circuit board, take precautions not to lose any part of the rivets.
- (5) The lamp holder is clamped on to the light guide in two places. While holding the board with your fingers so it does not move, first, wedge a flat-head screwdriver into the space between the board and one end of the lamp holder; next, very gently pry it loose (do not force it) from the fittings (Fig.19) ; then, repeat the procedure on the other end; and remove the lamp holder (Fig.20).

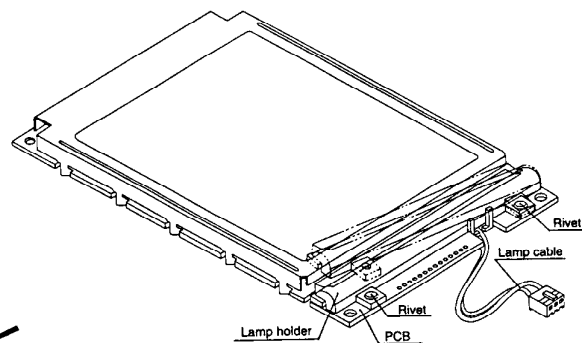

Figure 19

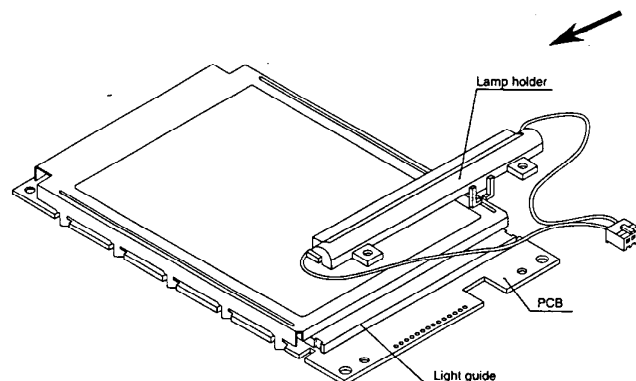

Figure 20

- (6) Loosen the cable of the replacement lamp so that it is easy to slip around the board. Because the cable is held tightly by the hook, pull it through the loop and loosen it.
- (7) Loop both wires around the board and through the notches so that the plug is under the board.
- (8) Doing one side at a time, align the clamps of the lamp holder with the notches on the light guide and snap on the lamp holder (Fig.21).
If the light guide moved when you removed the lamp holder and you are unable to locate the notches it, slightly slide the light guide up to reveal the notches.

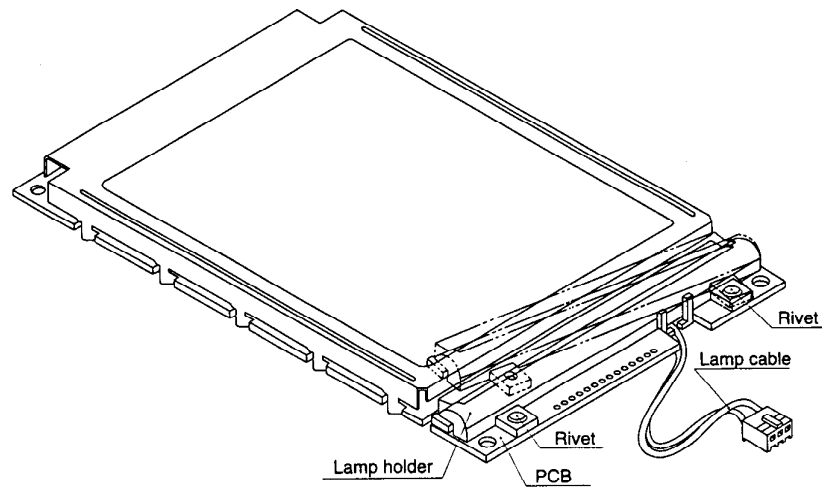

Figure 21

- (9) Reinsert both plastic rivets in their original positions in the following order: bush then pin. If any of the holes on either of the parts are unaligned, then move the lamp holder to align the holes.
- (10) Take up the slack on the lamp cable that goes through the notches on the circuit board and back through the hook of the lamp holder, and return it to its original position.

4. NOTES

Safety

- If the LCD panel is damaged, be careful not to get the liquid crystal in your mouth and not to be injured by crushed glasses.
- If you should swallow the liquid crystal, first, wash your mouth thoroughly with water, then, drink a lot of water and induce vomiting; and then, consult a physician.
- If the liquid crystal should get in your eye, flush your eye with running water for at least fifteen minutes.
- If the liquid crystal touches your skin or clothes, remove it and wash the affected part of your skin or clothes with soap and running water.
- High voltage is present between CFL electrodes. To prevent electric shock, do not touch the wiring while the power is on. Be sure to turn the power off when connecting or disconnecting the connector.
- Use the LCD module within the rated voltage to prevent overheating and/or damage. Also, take steps to ensure that the connector does not come off.

Handling

- Avoid static electricity, as this can damage the CMOS LSI.
- The LCD panel is made of plate glass; do not hit or press against it.
- Do not remove the panel or frame from the module.
- The polarizer on the display is very fragile; handle it very carefully.

Mounting and Design

- Mount the module using the specified installation sections and holes.
- To protect the module from external pressure, put a plate of transparent material such as acrylic or glass over the display surface, frame, and polarizer. Leave a small gap between the transparent plate and the module.

☆Example

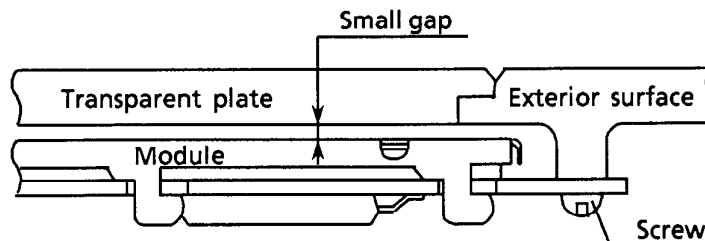

- Keep the module dry. Condensation can damage the transparent electrodes.
- If the CFL lamp and its wiring are located close to a metal plate or metal foil, the stray capacity will cause the voltage to fall, which will decrease the brightness and increase the starting voltage. Be careful in designing the casing and the CFL wiring.

Storage

- Store the module in a dark place where the temperature is $25^{\circ}\text{C} \pm 10^{\circ}\text{C}$ and the humidity is below 65% RH.
- Do not store the module near organic solvents or corrosive gases.
- Do not crush, shake, or jar the module or its components.
- Black or white air-bubbles may be produced if the module is stored for a long time in the lower temperature or mechanical shocks are applied onto the module.

Cleaning

- Do not wipe the polarizer with a dry cloth, as it may scratch the surface.
- Wipe the module gently with a soft cloth soaked with a petroleum benzine.
- Do not use ketonic solvents (ketone and acetone) or aromatic solvents (toluene and xylene), as they may damage the polarizer.

Index

-B-

Backlight ON/OFF control	21, 22
Bias value	6
Bias voltage generation circuit	8, 11
Block diagram	8
Brightness	18

-C-

CFL backlight drive signal	5, 19
CFL backlighting	1, 18
CFL inverter	18, 19
Chip enable function	9
Cleaning	26
Common drive waveform	9
Common driver	8, 9, 13
Connector for CFL backlight	19
Contrast	3, 4
Current consumption	3

-D-

Definition of contrast	4
Definition of response time	4
Definition of viewing angles	4
Display data input	5
Display data shift clock	5, 9
Display ON/OFF control terminal	5
Drive waveform	6, 7

-E-

Effective voltage	6
-------------------------	---

-F-

Flicker	6
Frame frequency	2, 3, 4, 6
Frame ground	5
FSTN	1, 2, 3, 10

-H-

HITACHI HD64646FS	14, 17
-------------------------	--------

-I-		
	Input current	20
	Input voltage	2, 3
	Input signal	12
	I/O terminal functions	5
-L-		
	Lamp current	18
	Lamp voltage	18
	LCD controller	14
	Lifetime	4
	Liquid crystal drive voltage adjustment terminal	5
	Liquid crystal AC drive control signal	5, 6, 9, 11
	Liquid crystal operating voltage	10
-M-		
	M' generation circuit	8, 11
-N-		
	Negative mode	1, 6
	Non-selection waveform	6, 7
-O-		
	OKI MSM6255GSK	14, 15
	One-common-line timing signal	5, 9, 11
	One-frame timing signal	5, 9, 11
	Operating humidity	19
	Operating temperature	2, 19
	Operational amplifier	10, 11
	Output current	20
-P-		
	Positive mode	1, 6
	Power supply current	20
	Power supply voltage	2, 3, 5, 19, 20, 22
-R-		
	Resistance division	11
	Response time (fall)	3, 4
	Response time (rise)	3, 4

-S-

Segment drive waveform	9
Segment driver	8, 9, 13
SEIKO EPSON SED1330F	14, 16
Selection waveform	6, 7
Service life	19
Side lighting	1
STN	1, 3, 10
Storage	26
Storage humidity	2, 19
Storage temperature	2, 19

-T-

Temperature of transformer	21
----------------------------------	----

-V-

Viewing angle	1, 3, 4
V _{opr} control circuit	8, 10

Seiko Instruments Inc.

Head Office

Components Sales Department
1-8, Nakase, Mihama-ku, Chiba-shi, Chiba 261, Japan
Phone: 043-211-1216 FAX: 043-211-8035

Seiko Instruments U.S.A. Inc.

Electronic Components Division
2990 W. Lomita Blvd., Torrance Calif. 90505, USA Phone: 310-517-7770 FAX: 310-517-7792

Seiko Instruments GmbH

Siemensstrasse 9b, 63263 Neu-Isenburg, Germany Phone: 49-6102-297-0 FAX: 49-6102-297-222

Seiko Instruments (H. K.) Ltd. Sales Division

4-5/F, Wyler Centre 2, 200 Tai Lin Pai Road, Kwai Chung, N.T., Kowloon, Hong Kong
Phone: 852-24218611 FAX: 852-24805479.

Seiko Instruments Taiwan Inc.

5F-1 No. 99, SEC.2, Chung Shan N. Rd., Taipei 104, Taiwan, R.O.C.
Phone: 886-2-563-5001 FAX: 886-2-521-9519

Seiko Instruments Singapore Pte. Ltd

2, Marsiling Lane Woodland New Town Singapore 2573
Phone: 65-2691370 FAX: 65-2699729