

Features

- 0805 size
- Magnetic shielding
- High Q characteristics
- Nickel barrier
- Lead free

Applications

- Prevention of electro-magnetic interference to signals on the secondary side of electronic equipment

Model CS201210 is currently available, although not recommended for new designs. Use Model CV201210.

CS201212 Series - Ferrite Multi-Layer Chip Inductors

Electrical Specifications

| Bourns Part No. | Inductance | | Q | Test Freq. | SRF MHz | | DCR | I rms |
|-----------------|------------|--------|------|------------|---------|------|---------|---------|
| | μH | Tol. % | typ. | L,Q MHz | min. | typ. | mΩ max. | mA max. |
| CS201212-47NK | 0.047 | ±10 | 60 | 50 | 320 | 400 | 100 | 300 |
| CS201212-56NK | 0.056 | ±10 | 60 | 50 | 300 | 380 | 150 | 300 |
| CS201212-68NK | 0.068 | ±10 | 60 | 50 | 280 | 350 | 200 | 300 |
| CS201212-82NK | 0.082 | ±10 | 60 | 50 | 255 | 320 | 200 | 300 |
| CS201212-R10K | 0.10 | ±10 | 50 | 25 | 235 | 300 | 200 | 250 |
| CS201212-R12K | 0.12 | ±10 | 50 | 25 | 220 | 280 | 200 | 250 |
| CS201212-R15K | 0.15 | ±10 | 50 | 25 | 200 | 250 | 200 | 250 |
| CS201212-R18K | 0.18 | ±10 | 50 | 25 | 185 | 230 | 200 | 250 |
| CS201212-R22K | 0.22 | ±10 | 50 | 25 | 170 | 220 | 250 | 250 |
| CS201212-R27K | 0.27 | ±10 | 50 | 25 | 150 | 200 | 300 | 250 |
| CS201212-R33K | 0.33 | ±10 | 50 | 25 | 145 | 180 | 300 | 150 |
| CS201212-R39K | 0.39 | ±10 | 50 | 25 | 135 | 170 | 400 | 200 |
| CS201212-R47K | 0.47 | ±10 | 50 | 25 | 125 | 160 | 400 | 200 |
| CS201212-R56K | 0.56 | ±10 | 50 | 25 | 115 | 150 | 400 | 150 |
| CS201212-R68K | 0.68 | ±10 | 50 | 25 | 105 | 135 | 600 | 150 |
| CS201212-R82K | 0.82 | ±10 | 75 | 25 | 100 | 125 | 300 | 150 |
| CS201212-1R0K | 1.0 | ±10 | 75 | 10 | 75 | 105 | 400 | 100 |
| CS201212-1R2K | 1.2 | ±10 | 75 | 10 | 65 | 95 | 400 | 100 |
| CS201212-1R5K | 1.5 | ±10 | 75 | 10 | 60 | 85 | 400 | 100 |
| CS201212-1R8K | 1.8 | ±10 | 75 | 10 | 55 | 75 | 400 | 100 |
| CS201212-2R2K | 2.2 | ±10 | 80 | 10 | 50 | 70 | 400 | 50 |
| CS201212-2R7K | 2.7 | ±10 | 80 | 10 | 45 | 65 | 500 | 50 |
| CS201212-3R3K | 3.3 | ±10 | 80 | 10 | 40 | 55 | 500 | 50 |
| CS201212-3R9K | 3.9 | ±10 | 80 | 10 | 38 | 50 | 1000 | 50 |
| CS201212-4R7K | 4.7 | ±10 | 80 | 10 | 35 | 48 | 1300 | 50 |
| CS201212-5R6K | 5.6 | ±10 | 60 | 4 | 32 | 45 | 500 | 50 |
| CS201212-6R8K | 6.8 | ±10 | 60 | 4 | 29 | 40 | 600 | 25 |
| CS201212-8R2K | 8.2 | ±10 | 60 | 4 | 26 | 36 | 700 | 25 |
| CS201212-100K | 10.0 | ±10 | 60 | 2 | 24 | 33 | 800 | 25 |
| CS201212-120K | 12.0 | ±10 | 60 | 2 | 22 | 30 | 800 | 25 |
| CS201212-150K | 15.0 | ±10 | 40 | 1 | 19 | 27 | 1400 | 15 |
| CS201212-180K | 18.0 | ±10 | 40 | 1 | 18 | 25 | 1400 | 15 |
| CS201212-220K | 22.0 | ±10 | 40 | 1 | 16 | 22 | 700 | 5 |
| CS201212-270K | 27.0 | ±10 | 40 | 1 | 14 | 20 | 800 | 5 |
| CS201212-330K | 33.0 | ±10 | 40 | 0.4 | 13 | 18 | 1000 | 5 |

General Specifications

Temperature Rise20 °C max. at rated current
 Operating Temperature-55 °C to +125 °C
 Storage Temperature-55 °C to +125 °C
 Reflow Soldering ...230 °C, 50 sec. max.
 Resistance to Soldering Heat260 °C, 10 seconds

Materials

Base MaterialFerrite
 TerminalAg/Ni/Sn
 Packaging3,000 pcs. per reel

Product Dimensions

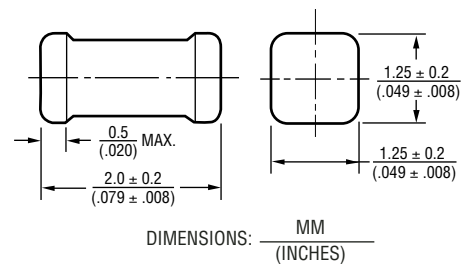

Recommended Layout

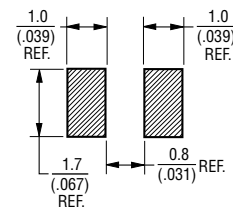

Packaging Specifications

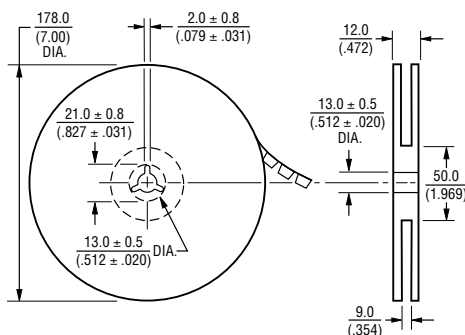

*RoHS Directive 2002/95/EC Jan 27 2003 including Annex Specifications are subject to change without notice. Customers should verify actual device performance in their specific applications.

CS201212 Series - Ferrite Multi-Layer Chip Inductors **BOURNS®**

Electrical Specifications

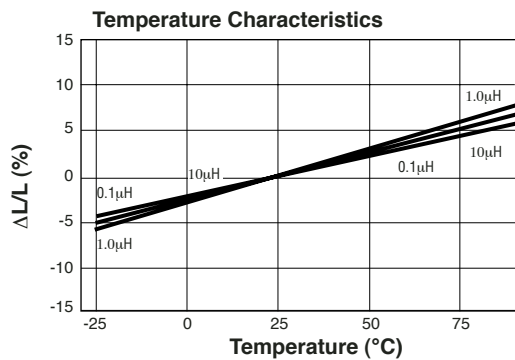
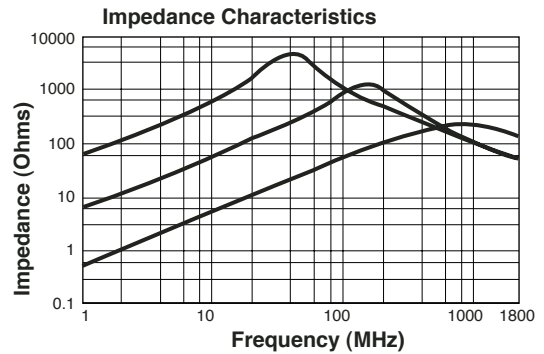
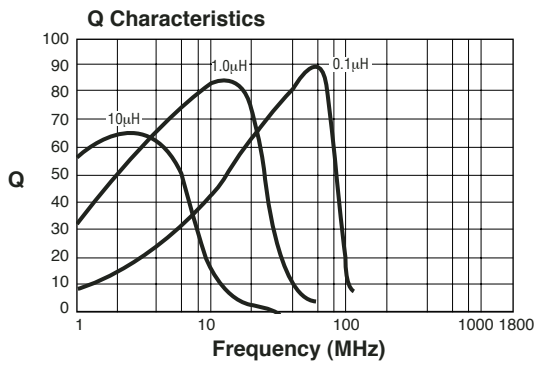
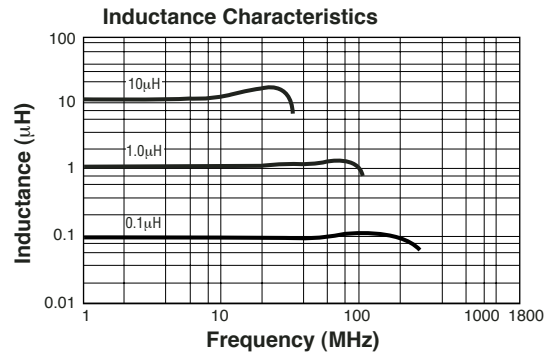
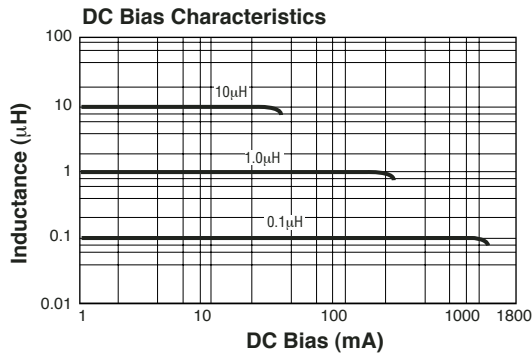

REV. 07/05

Specifications are subject to change without notice.
Customers should verify actual device performance in their specific applications.