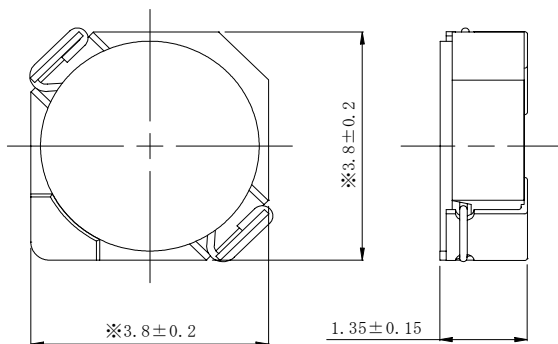

Type: CDRH3D14, CDRH3D14/HP, CDRH3D14/LD
◆ Product Description

- 4.0×4.0mm Max.(L×W), 1.5mm Max. Height.
- Standard type CDRH3D14, High Power Type CDRH3D14/HP and Low DCR type CDRH3D14/LD are available.
- Inductance range: 1.2~22 μ H(CDRH3D14); 1.5~22 μ H(CDRH3D14/HP); 1.2~47 μ H(CDRH3D14/LD);
- Rated current range: 0.43~2.15A(CDRH3D14); 0.48~1.85A(CDRH3D14/HP); 0.25~1.5A(CDRH3D14/LD).
- In addition to the standards versions shown here, custom inductors are also available to meet your exact requirements.

◆ Feature

- Magnetically shielded construction.
- Ideally used in Mobile phone, PDA, MP3, HDD, DSC/DVC, etc as DC-DC Converter inductors.
- RoHS Compliance.

◆ Dimensions (mm)

※Not including terminal dimension.

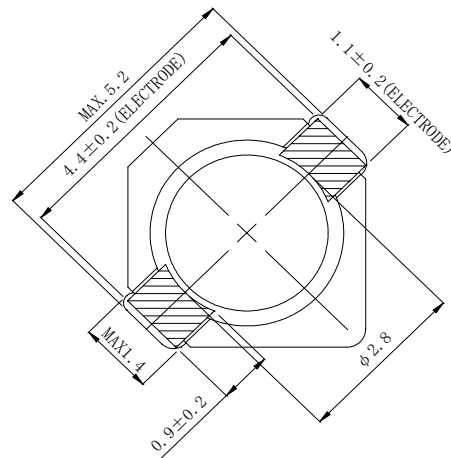
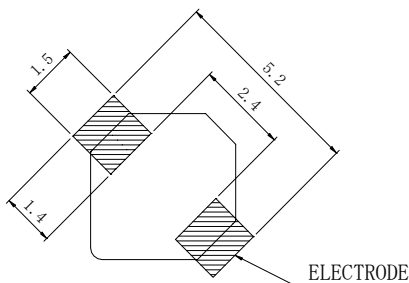
◆ Land Pattern (mm)

Type: CDRH3D14,CDRH3D14/HP,CDRH3D14/LD
◆ Specification(CDRH3D14)

Part Name ※	Stamp	Inductance [Within] 100kHz/1V	D.C.R.(mΩ) Max.(Typ.) (at 20°C)	Saturation Current (A) ※1		Temperature Rise current (A) ※2
				(at20°C)	(at105°C)	
CDRH3D14NP-1R2N□	A	1.2 μH ±25%	45(36)	2.15	1.50	2.20
CDRH3D14NP-1R7N□	B	1.7 μH ±25%	63(50)	1.85	1.35	2.00
CDRH3D14NP-2R2N□	D	2.2 μH ±25%	69(55)	1.60	1.25	1.75
CDRH3D14NP-2R7N□	E	2.7 μH ±25%	88(70)	1.45	1.15	1.36
CDRH3D14NP-3R3N□	F	3.3 μH ±25%	100(80)	1.35	0.96	1.24
CDRH3D14NP-3R9N□	G	3.9 μH ±25%	135(110)	1.15	0.82	1.12
CDRH3D14NP-4R7N□	H	4.7 μH ±25%	150(120)	1.10	0.76	0.96
CDRH3D14NP-8R2N□	L	8.2 μH ±25%	238(190)	0.82	0.64	0.74
CDRH3D14NP-10ØN□	M	10 μH ±25%	262(210)	0.75	0.55	0.69
CDRH3D14NP-12ØN□	N	12 μH ±25%	350(280)	0.67	0.50	0.60
CDRH3D14NP-15ØN□	P	15 μH ±25%	488(390)	0.60	0.48	0.58
CDRH3D14NP-22ØN□	R	22 μH ±25%	575(460)	0.52	0.37	0.43

◆ Specification(CDRH3D14/HP)

Part Name ※	Stamp	Inductance [Within] 100kHz/1V	D.C.R.(mΩ) Max.(Typ.) (at 20°C)	Saturation Current (A) ※1		Temperature Rise current (A) ※2
				(at20°C)	(at100°C)	
CDRH3D14/HPNP-1R5N□	A	1.5 μH ±25%	76(61)	2.60	2.00	1.85
CDRH3D14/HPNP-2R4N□	C	2.4 μH ±25%	129(103)	2.00	1.60	1.32
CDRH3D14/HPNP-3R2N□	E	3.2 μH ±25%	139(111)	1.80	1.40	1.25
CDRH3D14/HPNP-4R7N□	G	4.7 μH ±25%	214(171)	1.45	1.15	1.04
CDRH3D14/HPNP-6R8N□	J	6.8 μH ±25%	290(232)	1.20	0.95	0.84
CDRH3D14/HPNP-10ØN□	L	10 μH ±25%	440(352)	1.00	0.75	0.67
CDRH3D14/HPNP-15ØN□	N	15 μH ±25%	650(521)	0.80	0.62	0.50
CDRH3D14/HPNP-22ØN□	Q	22 μH ±25%	830(666)	0.65	0.52	0.48

Type: CDRH3D14,CDRH3D14/HP,CDRH3D14/LD
◆ Specification(CDRH3D14/LD)

Part Name ※	Stamp	Inductance [Within] 100kHz/1V	D.C.R.(mΩ) Max.(Typ.) (at 20°C)	Saturation Current (A) ※1		Temperature Rise current (A) ※2
				(at 20°C)	(at 100°C)	
CDRH3D14/LDNP-1R2N□	A	1.2 μH ± 25%	38(30)	1.50	1.28	2.70
CDRH3D14/LDNP-1R5N□	B	1.5 μH ± 25%	48(38)	1.35	1.05	2.40
CDRH3D14/LDNP-2R0N□	C	2.0 μH ± 25%	55(44)	1.15	0.95	2.20
CDRH3D14/LDNP-2R5N□	D	2.5 μH ± 25%	68(54)	1.05	0.80	1.90
CDRH3D14/LDNP-3R0N□	E	3.0 μH ± 25%	77(62)	0.95	0.75	1.60
CDRH3D14/LDNP-3R9N□	F	3.9 μH ± 25%	96(77)	0.80	0.65	1.50
CDRH3D14/LDNP-4R5N□	G	4.5 μH ± 25%	105(84)	0.75	0.60	1.45
CDRH3D14/LDNP-5R6N□	H	5.6 μH ± 25%	159(127)	0.70	0.55	1.10
CDRH3D14/LDNP-6R8N□	I	6.8 μH ± 25%	173(138)	0.60	0.50	1.05
CDRH3D14/LDNP-100N□	K	10 μH ± 25%	220(176)	0.50	0.38	1.00
CDRH3D14/LDNP-120N□	L	12 μH ± 25%	270(216)	0.45	0.35	0.80
CDRH3D14/LDNP-150N□	M	15 μH ± 25%	302(242)	0.40	0.30	0.75
CDRH3D14/LDNP-220N□	O	22 μH ± 25%	447(358)	0.35	0.27	0.60
CDRH3D14/LDNP-330N□	Q	33 μH ± 25%	848(679)	0.30	0.25	0.40
CDRH3D14/LDNP-470N□	R	47 μH ± 25%	1078(863)	0.25	0.20	0.35

※ Description of part name

CDRH3D14/LDNP-1R2N□

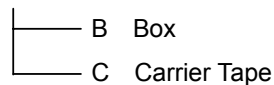

※1.Saturation Current: The DC current at which the inductance decreases to 65% of it's nominal value

※2 Temperature rise current:The DC current at which the temperature rise is Δt=40°C.(Ta=20°C)