

# Chip Inductor (Chip Coil) for High Frequency Vertical Wire Wound Ferrite Type

## LQH31H Series (1206 Size)

### ■ Dimensions

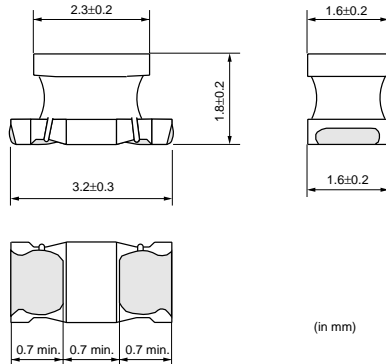

### ■ Packaging

Code	Packaging	Minimum Quantity
L	180mm Embossed Tape	2000
K	330mm Embossed Tape	7500

### ■ Rated Value (□: packaging code)

Part Number	Inductance	Test Frequency	Rated Current	DC Resistance	Q (min.)	Test Frequency	Self Resonance Frequency (min.)
LQH31HN54NK03□	54nH±10%	1MHz	920mA	0.035ohm±30%	50	100MHz	800MHz
LQH31HN95NK03□	95nH±10%	1MHz	790mA	0.047ohm±30%	60	100MHz	650MHz
LQH31HNR14J03□	145nH±5%	1MHz	700mA	0.061ohm±30%	60	100MHz	500MHz
LQH31HNR14K03□	145nH±10%	1MHz	700mA	0.061ohm±30%	60	100MHz	500MHz
LQH31HNR21J03□	215nH±5%	1MHz	520mA	0.11ohm±30%	60	100MHz	430MHz
LQH31HNR21K03□	215nH±10%	1MHz	520mA	0.11ohm±30%	60	100MHz	430MHz
LQH31HNR29J03□	290nH±5%	1MHz	420mA	0.17ohm±30%	60	100MHz	360MHz
LQH31HNR29K03□	290nH±10%	1MHz	420mA	0.17ohm±30%	60	100MHz	360MHz
LQH31HNR39J03□	390nH±5%	1MHz	330mA	0.26ohm±30%	60	100MHz	300MHz
LQH31HNR39K03□	390nH±10%	1MHz	330mA	0.26ohm±30%	60	100MHz	300MHz
LQH31HNR50J03□	500nH±5%	1MHz	260mA	0.44ohm±30%	60	100MHz	270MHz
LQH31HNR50K03□	500nH±10%	1MHz	260mA	0.44ohm±30%	60	100MHz	270MHz
LQH31HNR61J03□	610nH±5%	1MHz	250mA	0.48ohm±30%	60	100MHz	240MHz
LQH31HNR61K03□	610nH±10%	1MHz	250mA	0.48ohm±30%	60	100MHz	240MHz
LQH31HNR75J03□	750nH±5%	1MHz	190mA	0.79ohm±30%	60	100MHz	220MHz
LQH31HNR75K03□	750nH±10%	1MHz	190mA	0.79ohm±30%	60	100MHz	220MHz
LQH31HNR88J03□	880nH±5%	1MHz	180mA	0.86ohm±30%	60	100MHz	200MHz
LQH31HNR88K03□	880nH±10%	1MHz	180mA	0.86ohm±30%	60	100MHz	200MHz

Operating Temperature Range: -40°C to +85°C

Continued on the following page. [↗](#)

● This data sheet is applied for CHIP INDUCTORS (CHIP COILS) used for General Electronics equipment for your design.

### ⚠ Note:

1. This datasheet is downloaded from the website of Murata Manufacturing Co., Ltd. Therefore, it's specifications are subject to change or our products in it may be discontinued without advance notice. Please check with our sales representatives or product engineers before ordering.
2. This datasheet has only typical specifications because there is no space for detailed specifications. Therefore, please approve our product specifications or transact the approval sheet for product specifications before ordering.

Continued from the preceding page.

### Q-Frequency Characteristics (Typ.)

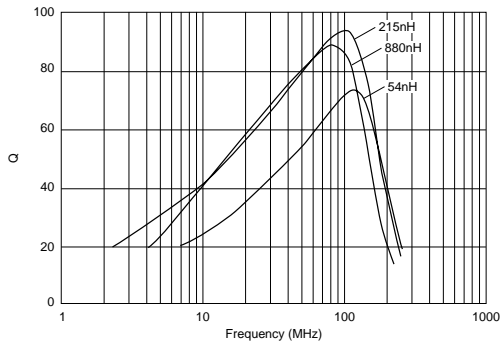

### ⚠ Caution/Notice

#### ⚠ Caution (Rating)

Do not use products beyond the rated current as this may create excessive heat.

#### Notice

Solderability of Tin plating termination chip might be deteriorated when low temperature soldering profile where peak solder temperature is below the Tin melting point is used. Please confirm the solderability of Tin plating termination chip before use.

● This data sheet is applied for CHIP INDUCTORS (CHIP COILS) used for General Electronics equipment for your design.

#### ⚠ Note:

1. This datasheet is downloaded from the website of Murata Manufacturing co., Ltd. Therefore, it's specifications are subject to change or our products in it may be discontinued without advance notice. Please check with our sales representatives or product engineers before ordering.
2. This datasheet has only typical specifications because there is no space for detailed specifications. Therefore, please approve our product specifications or transact the approval sheet for product specifications before ordering.