

# Chip Inductors (Chip Coils) for DC-DC Converter Wire Wound Type

## LQH2MC\_52 Series (0806 Size)

### Dimension

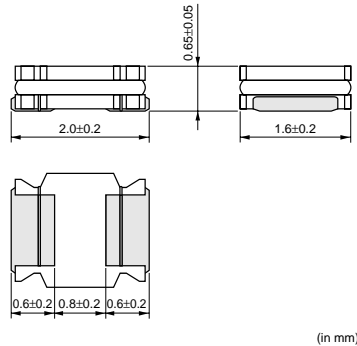

### Packaging

Code	Packaging	Minimum Quantity
L	180mm Embossed Tape	3000
B	Bulk(Bag)	100

### Rated Value (□: packaging code)

Part Number	Inductance	Inductance Test Frequency	Allowable DC Current (Based on Temperature Rise)	Allowable DC Current (Based on Inductance Change)	DC Resistance	Self Resonance Frequency (min.)	Class of Magnetic Shield
LQH2MCN1R0M52□	1.0μH±20%	1MHz	595mA	-	0.25ohm±30%	215MHz	No magnetic shield
LQH2MCN1R5M52□	1.5μH±20%	1MHz	540mA	-	0.33ohm±30%	165MHz	No magnetic shield
LQH2MCN2R2M52□	2.2μH±20%	1MHz	500mA	-	0.42ohm±30%	125MHz	No magnetic shield
LQH2MCN3R3M52□	3.3μH±20%	1MHz	360mA	-	0.74ohm±30%	110MHz	No magnetic shield
LQH2MCN4R7M52□	4.7μH±20%	1MHz	335mA	-	0.91ohm±30%	90MHz	No magnetic shield
LQH2MCN6R8M52□	6.8μH±20%	1MHz	285mA	-	1.23ohm±30%	65MHz	No magnetic shield
LQH2MCN100M52□	10μH±20%	1MHz	200mA	-	2.27ohm±30%	60MHz	No magnetic shield
LQH2MCN120M52□	12μH±20%	1MHz	170mA	-	2.4ohm±30%	30MHz	No magnetic shield
LQH2MCN150M52□	15μH±20%	1MHz	150mA	-	3.5ohm±30%	30MHz	No magnetic shield
LQH2MCN180M52□	18μH±20%	1MHz	140mA	-	4.0ohm±30%	30MHz	No magnetic shield
LQH2MCN220M52□	22μH±20%	1MHz	130mA	-	5.5ohm±30%	30MHz	No magnetic shield

Operating Temperature Range: -40°C to +85°C  
Only for reflow soldering.

### Notice (Allowable DC Current)

<Allowable DC Current>

When Allowable DC Current is applied to the Products, self-generation of heat will rise to 40°C or less.

When Allowable DC Current is applied to the Products, Inductance will be within +30% of nominal Inductance value.

Continued on the following page.

● This data sheet is applied for CHIP INDUCTORS (CHIP COILS) used for General Electronics equipment for your design.

### Note:

1. This datasheet is downloaded from the website of Murata Manufacturing co., Ltd. Therefore, it's specifications are subject to change or our products in it may be discontinued without advance notice. Please check with our sales representatives or product engineers before ordering.
2. This datasheet has only typical specifications because there is no space for detailed specifications. Therefore, please approve our product specifications or transact the approval sheet for product specifications before ordering.

Continued from the preceding page.

### Inductance - Frequency Characteristics (Typ.)

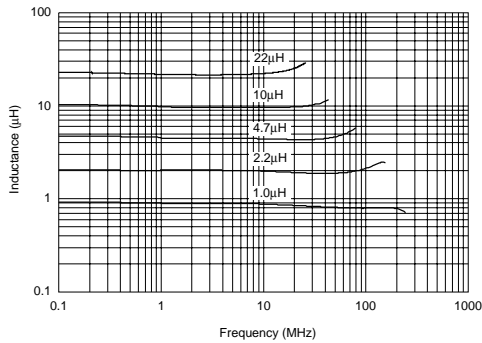

### Inductance - Current Characteristics (Typ.)

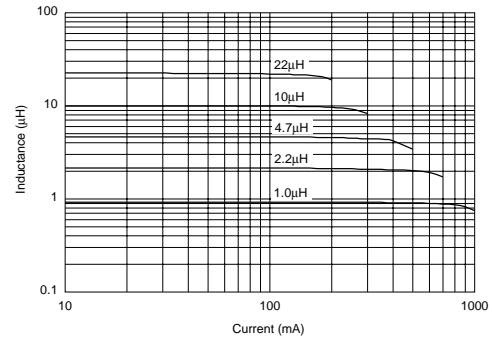

### Caution/Notice

#### Caution (Rating)

Do not use products beyond the rated current as this may create excessive heat.

#### Notice

Solderability of Tin plating termination chip might be deteriorated when low temperature soldering profile where peak solder temperature is below the Tin melting point is used. Please confirm the solderability of Tin plating termination chip before use.

This data sheet is applied for CHIP INDUCTORS (CHIP COILS) used for General Electronics equipment for your design.

#### Note:

- This datasheet is downloaded from the website of Murata Manufacturing co., Ltd. Therefore, it's specifications are subject to change or our products in it may be discontinued without advance notice. Please check with our sales representatives or product engineers before ordering.
- This datasheet has only typical specifications because there is no space for detailed specifications. Therefore, please approve our product specifications or transact the approval sheet for product specifications before ordering.