

Chip Inductor (Chip Coil) for High Frequency Vertical Wire Wound

LQW31H Series (1206 Size)

■ Dimensions

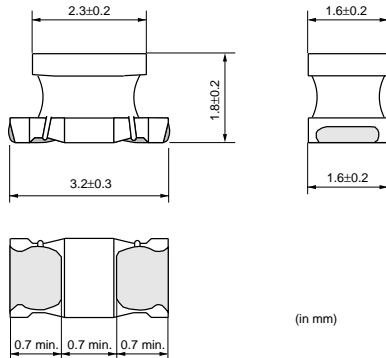

■ Packaging

Code	Packaging	Minimum Quantity
L	180mm Embossed Tape	2000
K	330mm Embossed Tape	7500

■ Rated Value (□: packaging code)

Part Number	Inductance	Test Frequency	Rated Current	DC Resistance	Q (min.)	Test Frequency	Self Resonance Frequency (min.)
LQW31HN8N8J03□	8.8nH±5%	100MHz	750mA	0.029ohm±40%	50	436MHz	1000MHz
LQW31HN8N8K03□	8.8nH±10%	100MHz	750mA	0.029ohm±40%	50	436MHz	1000MHz
LQW31HN15NJ03□	14.7nH±5%	100MHz	680mA	0.035ohm±40%	60	436MHz	1000MHz
LQW31HN15NK03□	14.7nH±10%	100MHz	680mA	0.035ohm±40%	60	436MHz	1000MHz
LQW31HN17NJ03□	17nH±5%	100MHz	650mA	0.037ohm±40%	60	436MHz	1000MHz
LQW31HN17NK03□	17nH±10%	100MHz	650mA	0.037ohm±40%	60	436MHz	1000MHz
LQW31HN23NJ03□	23nH±5%	100MHz	590mA	0.046ohm±40%	60	436MHz	1000MHz
LQW31HN23NK03□	23nH±10%	100MHz	590mA	0.046ohm±40%	60	436MHz	1000MHz
LQW31HN27NJ03□	27nH±5%	100MHz	560mA	0.051ohm±40%	60	436MHz	1000MHz
LQW31HN27NK03□	27nH±10%	100MHz	560mA	0.051ohm±40%	60	436MHz	1000MHz
LQW31HN33NJ03□	33nH±5%	100MHz	530mA	0.057ohm±40%	60	436MHz	1000MHz
LQW31HN33NK03□	33nH±10%	100MHz	530mA	0.057ohm±40%	60	436MHz	1000MHz
LQW31HN39NJ03□	39nH±5%	100MHz	490mA	0.067ohm±40%	60	436MHz	1000MHz
LQW31HN39NK03□	39nH±10%	100MHz	490mA	0.067ohm±40%	60	436MHz	1000MHz
LQW31HN47NJ03□	47nH±5%	100MHz	380mA	0.11ohm±40%	60	436MHz	1000MHz
LQW31HN47NK03□	47nH±10%	100MHz	380mA	0.11ohm±40%	60	436MHz	1000MHz
LQW31HN56NJ03□	56nH±5%	100MHz	330mA	0.14ohm±40%	60	436MHz	1000MHz
LQW31HN56NK03□	56nH±10%	100MHz	330mA	0.14ohm±40%	60	436MHz	1000MHz
LQW31HN64NJ03□	64nH±5%	100MHz	290mA	0.18ohm±40%	60	436MHz	1000MHz
LQW31HN64NK03□	64nH±10%	100MHz	290mA	0.18ohm±40%	60	436MHz	1000MHz
LQW31HN84NJ03□	84nH±5%	100MHz	240mA	0.28ohm±40%	60	436MHz	1000MHz
LQW31HN84NK03□	84nH±10%	100MHz	240mA	0.28ohm±40%	60	436MHz	1000MHz
LQW31HNR10J03□	100nH±5%	100MHz	230mA	0.3ohm±40%	60	436MHz	900MHz
LQW31HNR10K03□	100nH±10%	100MHz	230mA	0.3ohm±40%	60	436MHz	900MHz

Operating Temperature Range: -40°C to +85°C

Continued on the following page. [↗](#)

● This data sheet is applied for CHIP INDUCTORS (CHIP COILS) used for General Electronics equipment for your design.

⚠ Note:

1. This datasheet is downloaded from the website of Murata Manufacturing Co., Ltd. Therefore, it's specifications are subject to change or our products in it may be discontinued without advance notice. Please check with our sales representatives or product engineers before ordering.
2. This datasheet has only typical specifications because there is no space for detailed specifications. Therefore, please approve our product specifications or transact the approval sheet for product specifications before ordering.

Continued from the preceding page.

Q-Frequency Characteristics (Typ.)

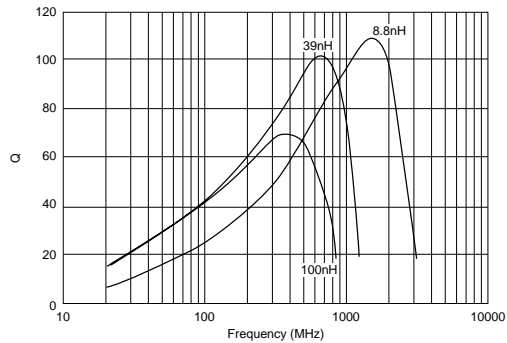

⚠ Caution/Notice

⚠ Caution (Rating)

Do not use products beyond the rated current as this may create excessive heat.

Notice

Solderability of Tin plating termination chip might be deteriorated when low temperature soldering profile where peak solder temperature is below the Tin melting point is used. Please confirm the solderability of Tin plating termination chip before use.

● This data sheet is applied for CHIP INDUCTORS (CHIP COILS) used for General Electronics equipment for your design.

⚠ Note:

1. This datasheet is downloaded from the website of Murata Manufacturing co., Ltd. Therefore, it's specifications are subject to change or our products in it may be discontinued without advance notice. Please check with our sales representatives or product engineers before ordering.
2. This datasheet has only typical specifications because there is no space for detailed specifications. Therefore, please approve our product specifications or transact the approval sheet for product specifications before ordering.