

# Type SCM Single/Dual IGBT Snubber Capacitor Modules

## Applications

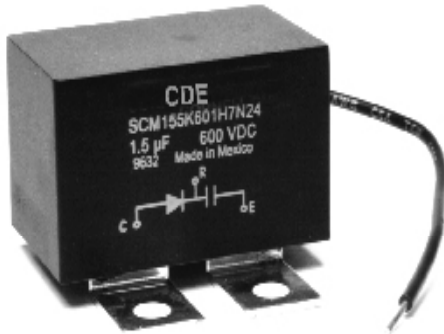

Use style SCM as a discharge restrictive de-coupling to protect dual IGBT modules from overvoltage, Figure 1. Style SCM may also be used as an “N” or “P” type snubber component for a clamp snubber where single IGBT modules are used, Figure 2.

## Highlights

- Mount directly to the IGBT module
- Low inductance
- Low Loss
- Hyperfast diodes integrated into package

## Discharge Restrictive De-coupling

The circuit in Figure 1 operates on the same principles as the de-coupling capacitor, but only during turn-off switching. As the IGBT turns off, energy trapped in the loop inductance is transferred to the capacitor. The diode blocks oscillations from occurring and excess charge on the capacitor is discharged through the external resistor.



Complies with the EU Directive 2002/95/EC requirement restricting the use of Lead (Pb), Mercury (Hg), Cadmium (Cd), Hexavalent chromium (Cr(VI)), PolyBrominated Biphenyls (PBB) and PolyBrominated Diphenyl Ethers (PBDE).

- 1 or 2 wire taps for connecting external resistor
- Flame resistant case and epoxy, meets UL 94V0
- Other terminal pitches and capacitance values available.

## RCD Clamp

The function of this snubber is similar to a clamp, Figure 2. At turn-off, the snubber diode is forward biased and the snubber is activated. The energy trapped in the stray inductance is absorbed by the snubber capacitor. During turn-on the snubber caps that were fully charged to bus voltage have a discharge path through the forward biased free-wheel diode, the IGBT, and the snubber resistors. This reduces the reverse recovery voltage transient.

Figure 1  
Style SCM Discharge restrictive decoupling used to protect dual IGBT modules

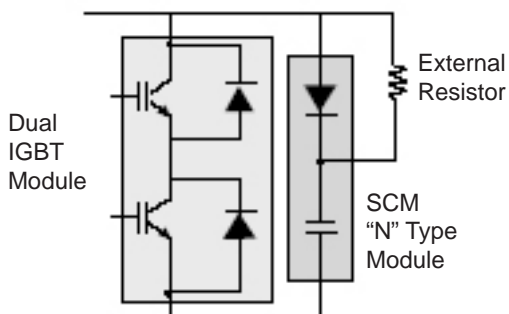
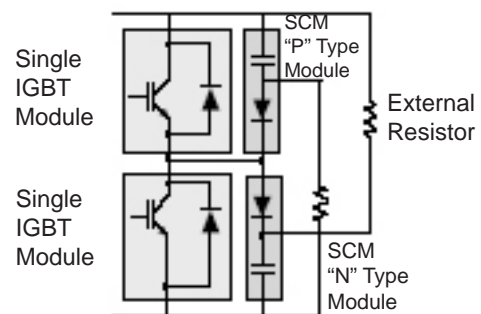
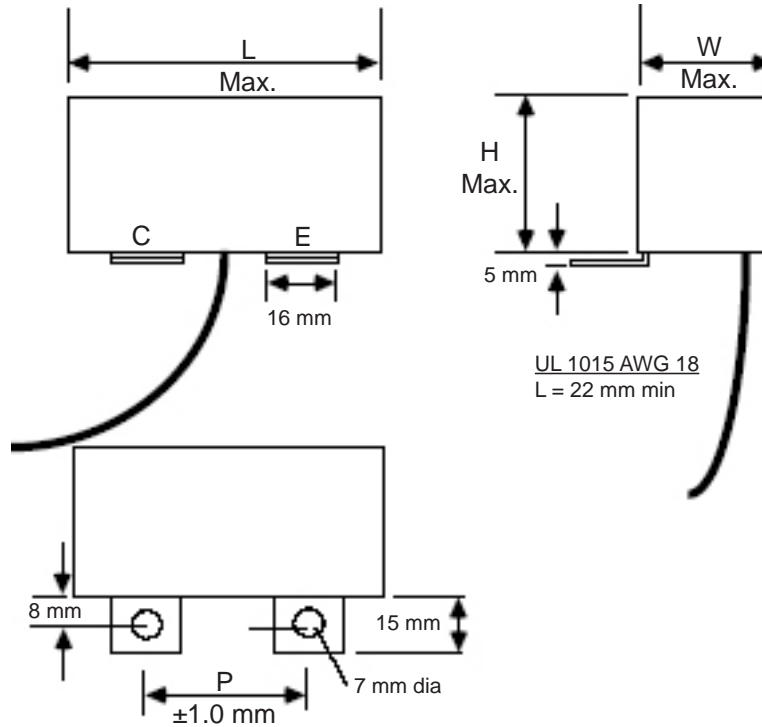

Figure 2  
Style SCM “P” type and “N” type used as a clamp to protect an inverter using two “single” IGBT modules



# Type SCM Single/Dual IGBT Snubber Capacitor Modules



## Ratings

Catalog Part Number	Cap ( $\mu$ F)	Typical Application IGBT Module			Diode Characteristics						Dimensions							
		S=Single D=Dual	Ic (A)	Vce (V)	Type	Vrrm (V)	If (A)	Trr ( $\mu$ s)	Ipk surge (A)	Ipk rep (A)	W (in) (mm)	L (in) (mm)	H (in) (mm)	P (in) (mm)				
SCM474K601H7N29-F	0.47	S	200-300	600	N	600	30	0.040	300	70	1.725	43.82	2.200	55.88	1.34	34.04	1.142	29
SCM474K601H7P29-F	0.47	S	200-300	600	P	600	30	0.040	300	70	1.725	43.82	2.200	55.88	1.34	34.04	1.142	29
SCM105K601H7N24-F	1.00	D	100-200	600	N	600	30	0.040	300	70	1.500	38.10	1.875	47.63	1.25	31.75	0.945	24
SCM105K601H7P24-F	1.00	D	100-200	600	P	600	30	0.040	300	70	1.500	38.10	1.875	47.63	1.25	31.75	0.945	24
SCM105K601H5N29-F	1.00	S	300-400	600	N	600	50	0.045	500	100	1.825	46.36	2.225	56.52	1.50	38.10	1.142	29
SCM105K601H5P29-F	1.00	S	300-400	600	P	600	50	0.045	500	100	1.825	46.36	2.225	56.52	1.50	38.10	1.142	29
SCM155K601H7N24-F	1.50	D	200-300	600	N	600	30	0.040	300	70	1.350	34.29	2.200	55.88	1.20	30.48	0.945	24
SCM155K601H7P24-F	1.50	D	200-300	600	P	600	30	0.040	300	70	1.500	38.10	1.875	47.63	1.25	31.75	0.945	24
SCM205K601H5N24-F	2.00	D	300-400	600	N	600	50	0.045	500	100	1.725	43.82	2.200	55.88	1.34	34.04	0.945	24
SCM205K601H5P24-F	2.00	D	300-400	600	P	600	50	0.045	500	100	1.725	43.82	2.200	55.88	1.34	34.04	0.945	24
SCM205K601H2N29-F	2.00	S	400-600	600	N	600	100	0.050	1000	200	1.825	46.36	2.225	56.52	1.50	38.10	1.142	29
SCM205K601H2P29-F	2.00	S	400-600	600	P	600	100	0.050	1000	200	1.825	46.36	2.225	56.52	1.50	38.10	1.142	29
SCM474K122H8N29-F	0.47	S	200-300	1200	N	1200	30	0.065	300	60	1.350	34.29	2.200	55.88	1.20	30.48	1.142	29
SCM474K122H8P29-F	0.47	S	200-300	1200	P	1200	30	0.065	300	60	1.500	38.10	1.875	47.63	1.25	31.75	1.142	29
SCM105K122H8N24-F	1.00	D	100-200	1200	N	1200	30	0.065	300	60	1.750	44.45	2.500	63.50	1.47	37.34	0.945	24
SCM105K122H8P24-F	1.00	D	100-200	1200	P	1200	30	0.065	300	60	1.750	44.45	2.500	63.50	1.47	37.34	0.945	24
SCM105K122H4N29-F	1.00	S	300-400	1200	N	1200	50	0.085	500	100	1.725	43.82	2.200	55.88	1.34	34.04	1.142	29
SCM105K122H4P29-F	1.00	S	300-400	1200	P	1200	50	0.085	500	100	1.825	46.36	2.225	56.52	1.50	38.10	1.142	29
SCM155K122H8N24-F	1.50	D	200-300	1200	N	1200	30	0.065	300	60	1.750	44.45	2.500	63.50	1.47	37.34	0.945	24
SCM155K122H8P24-F	1.50	D	200-300	1200	P	1200	30	0.065	300	60	1.825	46.36	2.225	56.52	1.50	38.10	0.945	24
SCM205K122H4N24-F	2.00	D	300-400	1200	N	1200	50	0.065	500	100	2.125	53.98	2.500	63.50	1.70	43.18	0.945	24
SCM205K122H4P24-F	2.00	D	300-400	1200	P	1200	50	0.065	500	100	2.125	53.98	2.500	63.50	1.70	43.18	0.945	24
SCM205K122H1N29-F	2.00	S	400-600	1200	N	1200	100	0.090	1000	200	2.125	53.98	2.500	63.50	1.70	43.18	1.142	29
SCM205K122H1P29-F	2.00	S	400-600	1200	P	1200	100	0.090	1000	200	2.125	53.98	2.500	63.50	1.70	43.18	1.142	29

Ipk surge at 25 °C and Ipk repetitive at 25 °C and 20 kHz.