

Double-Layer Capacitors in Cylindrical Metal Case with very High Capacitances in the Farad Range

Special Features

- Storage capacitors with very high capacitance values of 110 F and 200 F and a rated voltage of 2.5 VDC
- Discharge current up to 400 A
- Maintenance-free
- With cylindrical metal case
- Series connection possible
- According to RoHS 2002/95/EC

Typical Applications

Suitable for support, protection or replacement of batteries in the field of new traction technologies in

- Automotive
- Railway technology
- Wind power systems
- Uninterruptible power systems (UPS)

Construction

Internal construction:

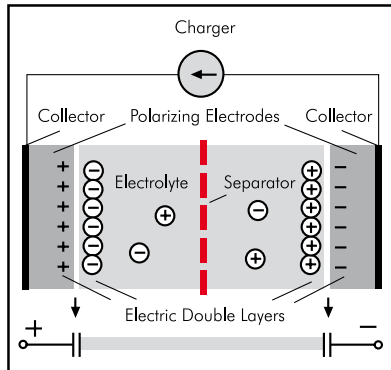

Encapsulation:

Cylindrical aluminium case

Terminations:

Lug terminals: Solder pin/4

Marking:

Colour: Black. Marking: Gold

1) Requirements:

$|\Delta C/C_N| \leq 30\%$, $ESR \leq 2$ times specified limit,
 $I_{leak} \leq 2$ times of initial value.

2) Test conditions:

$|\Delta C/C_N| \leq 30\%$, $ESR \leq 2$ times specified limit,
 $I_{leak} \leq 2$ times of initial value

(cycles: charging to U_R , 30 sec rest, discharging to $U_R/2$, 30 sec rest).

Technical Data

Capacitance:	C _N	110 F	200 F
Part number:		SCSCA1B110ZA00MV00	SCSCA1B200ZB00MV00
Capacitance tolerance:	-	±20%	±20%
Rated voltage:	U _R	2.5 V	2.5 V
Rated current:	I _C	30 A	45 A
Pulse current:	I _P	up to 220 A	up to 400 A
Internal resistance:	R _{DC}	11 mΩ	6 mΩ
Max. stored energy: ±20%	E _{max}	344 J	625 J
Operating temperature:	T _{op}	-30° C ... +65° C	
Storage temperature:	T _{st}	-40° C ... +70° C	
Weight:	m	40 g	65 g
Volume:	V	0.034 l	0.056 l

Additional Data

Case:	-	Al _{99.5}	Al _{99.5}
Lug terminals:	-	Solder pin/4	Solder pin/4

Comparative Data

Lifetime:			
in hours ¹⁾	h	90 000	90 000
in cycles ²⁾	Cycles	500 000	500 000
Energy density:			
gravimetric	E _d	2.4 Wh/kg	2.7 Wh/kg
volumetric	E _v	2.8 Wh/l	3.1 Wh/l

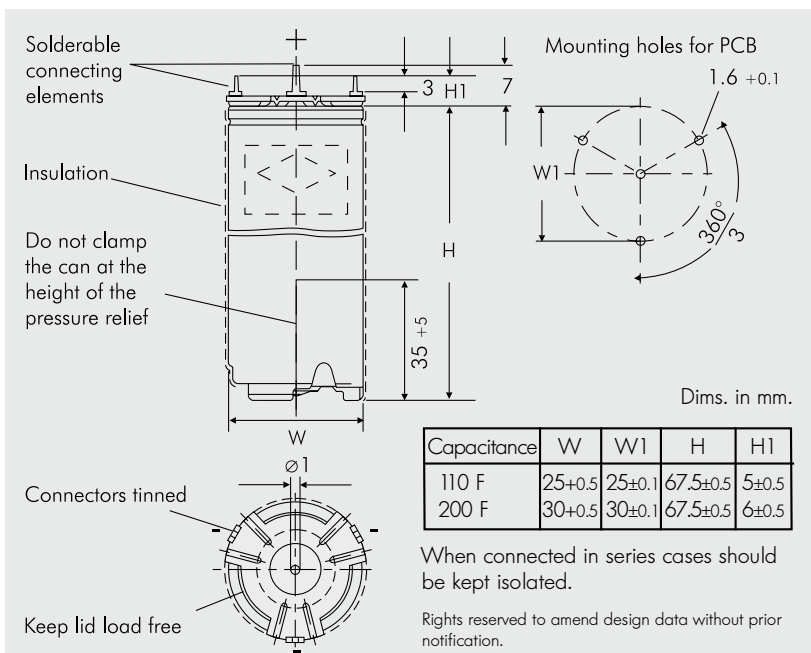

When connected in series cases should be kept isolated.

Rights reserved to amend design data without prior notification.

Double-Layer Capacitors in Cylindrical Metal Case with very High Capacitances in the Farad Range

Special Features

- Storage capacitors with very high capacitance values of 600 F and 1200 F and a rated voltage of 2.5 VDC
- Discharge current up to 2400 A
- Maintenance-free
- With cylindrical metal case
- Series connection possible
- According to RoHS 2002/95/EC

Typical Applications

Suitable for support, protection or replacement of batteries in the field of new traction technologies in

- Automotive
- Railway technology
- Wind power systems
- Uninterruptible power systems (UPS)

Construction

Internal construction:

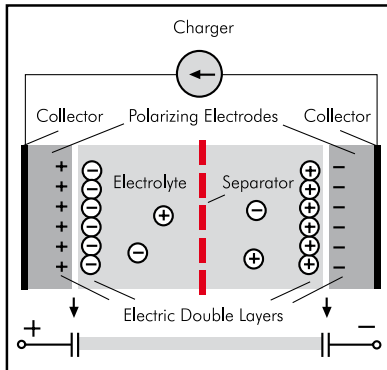

Encapsulation:

Cylindrical aluminium case

Terminations:

Weld terminals
optional screw terminations M8 x 12

Marking:

Colour: Black. Marking: Gold

1) Requirements:

$|\Delta C/C_N| \leq 30\%$, $ESR \leq 2$ times specified limit,
 $I_{leak} \leq 2$ times of initial value.

2) Test conditions:

$|\Delta C/C_N| \leq 30\%$, $ESR \leq 2$ times specified limit,
 $I_{leak} \leq 2$ times of initial value

(cycles: charging to U_R , 30 sec rest, discharging to $U_R/2$, 30 sec rest).

Technical Data

Capacitance:	C_N	600 F	1200 F
Part number:		SCSCA1B600ZD00MV00	SCSCA1C120ZC00MV00
Capacitance tolerance:	–	$\pm 20\%$	$\pm 20\%$
Rated voltage:	U_R	2.5 V	2.5 V
Rated current:	I_C	400 A	650 A
Pulse current:	I_P	up to 1400 A	up to 2400 A
Internal resistance:	R_{DC}	1.3 m Ω	0.9 m Ω
Max. stored energy: $\pm 20\%$	E_{max}	1875 J	3750 J
Operating temperature:	T_{op}	–30° C ... +65° C	
Storage temperature:	T_{st}	–40° C ... +70° C	
Weight:	m	170 g	235 g
Volume:	V	0.13 l	0.18 l

Additional Data

Case:	–	Al _{99.5}	Al _{99.5}
Weld terminations:	–	$\varnothing 28$	$\varnothing 28$

Comparative Data

Lifetime:			
in hours ¹⁾	h	90 000	90 000
in cycles ²⁾	Cycles	500 000	500 000
Energy density:			
gravimetric	E_d	3 Wh/kg	4.6 Wh/kg
volumetric	E_v	3.7 Wh/l	9.5 Wh/l

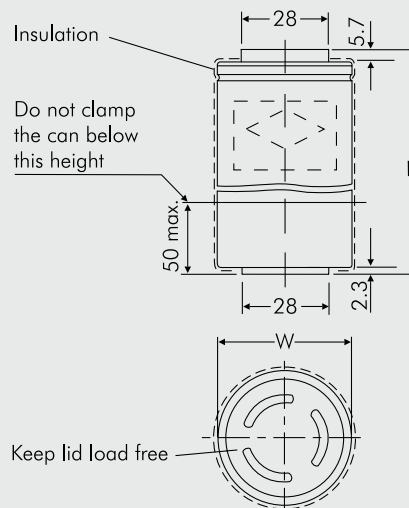

Capacitance	W	H
600 F	50 ± 0.5	75 ± 1
1200 F	50 ± 0.5	101 ± 1

Dims. in mm.

When connected in series cases should be kept isolated.

Rights reserved to amend design data without prior notification.

Technical Data and Applications of WIMA Double-Layer Capacitors



Construction Principle

The construction principle of a Double-Layer Capacitor can be described as a plate capacitor where the most important aim is to obtain electrodes with an extremely large surface. For this purpose activated carbon is ideally suited, as it allows to achieve capacitance values of up to 100 F/g of active mass of the electrode. The electrolyte, the conductive liquid between the electrodes is a conducting salt dissolved in an aqueous or organic solvent which permits to apply voltages of 2.5V.

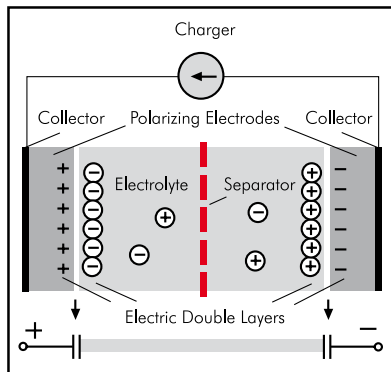

Construction principle of the WIMA Double-Layer Capacitor

The actual double-layer consists of ions which, when voltage is applied, attach to the positive or negative electrode corresponding to their opposite poles and thus create a dielectric gauge of a few Angstrom only. This results in a very high capacitance yield caused by the very huge surface of the electrode in accordance with the formula

$$C = \epsilon \times \frac{\text{Surface}}{\text{Distance}}$$

To visualise this, the internal surface of a Double-Layer Capacitor would cover a football pitch.

A permeable diaphragm acting as a separating layer and called separator avoids short-circuit between the two electrodes and considerably influences the characteristics of the capacitor. Charge or discharge of the Double-Layer Capacitor is combined with the transformation of the layers in the electrical field and thus with the movement of the charge carriers in

the solvent - even through the separator film. This phenomenon represents the main reason for the limited voltage capability of 2.5V only and the steep decrease of capacitance versus frequency exhibited by Double-Layer Capacitors.

Cascaded SuperCap Modules

Several SuperCap cells can be built up to enormous capacitances of the desired voltage by means of series or parallel connection (cascade). When cascading SuperCaps, the voltage of single cells must not exceed 2.5V (decomposition of the electrolyte!) Hence, series connections need in any case to be balanced since a possibly slightly different aging of the individual cells due to temperature may over time cause deviating capacitances and thus different voltage drops at the cell. The balancing will be factory-mounted into a module. This can be made passively and in a cost-efficient way by simple resistors in those cases where additional losses as bypass current through the balancing resistors can be tolerated by the application. Alternatively, an active balancing can be made by keeping each cell at a certain voltage by means of a reference source. That means if the comparator circuit detects a commencing overload of any cell individual discharge is initiated by a bypass resistor. Except the leakage current of the cells there are no considerable losses created during active balancing.

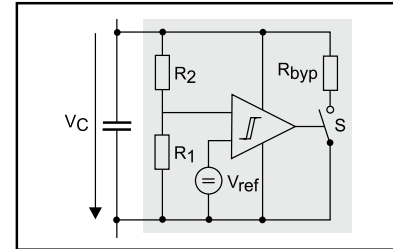

Active balancing.

Comparator compares voltage at the capacitor by a reference voltage and switches in order to discharge through a bypassing resistor until overvoltage has declined.

Operational Life

For physical reasons it is unavoidable that Double-Layer Capacitors are subjected to aging which follows the logarithmic dependence of voltage applied and ambient temperature (Arrhenius behaviour) that can be observed with other components, too. However, continuous studies have shown that WIMA products exhibit a significantly improved behaviour in terms of life time being achieved by a laser-welded, hermetically sealed construction of the cells in metal cases which makes penetration from outside impossible; they cannot dry up and can withstand a certain thermal expansion movement. Only by this innovation one can consider the component being suitable for long-year maintenance-free application.

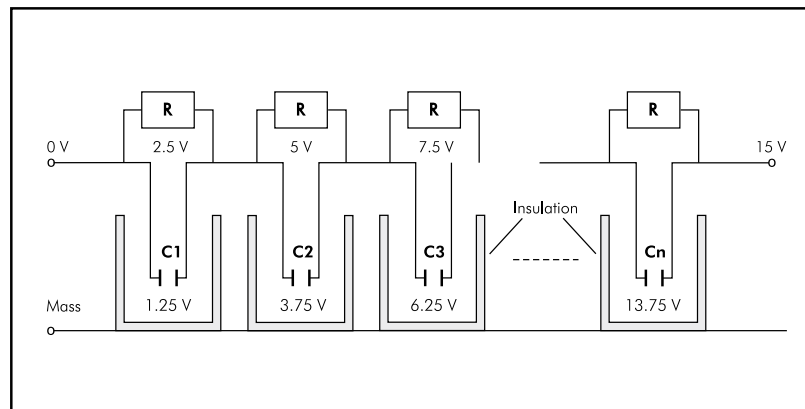

Passive balancing.

Without resistors: U reciprocal-effect to C - thus locale overvoltage easily can occur

With resistors: U proportional-effect to R - thus voltage is fixed

Technical Data and Applications of WIMA Double-Layer Capacitors

When properly treated WIMA SuperCaps have a service life beyond 10 years and can easily sustain more than 500.000 charge/discharge cycles. The efficiency is far higher than 90%.

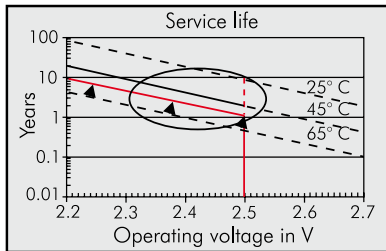

Life time expectancy for WIMA SuperCaps

Advantages in Comparison with other Energy Storage Solutions

WIMA SuperCaps are showing following advantages in comparison with other energy storage solutions:

- **Low internal resistance (less than 1/10 of what a usual battery exhibits)**
- **Release of high currents (10 to 100 times more than batteries)**
- **Maintenance-free operation**
- **No risk of damage due to complete discharge of the component**
- **High life expectancy**
- **Usage in isolated systems, e.g. inaccessible areas, is unproblematic**
- **Comparatively low weight**

WIMA Double-Layer Capacitors are particularly suitable in applications where high and even highest currents - not in pure AC operation - occur. By combining the advantage of conventional capacitors as fast suppliers of electricity with that of batteries as notable energy reservoirs the SuperCap represents the link between battery and conventional capacitor.

	Standard Capacitor	SuperCap	Battery
Capacitance per Surface	<1 $\mu\text{F}/\text{cm}^2$	1000 000 μF (1 F/cm ²)	
Energy-density	<0.01 Wh/kg	<10 Wh/kg	100 Wh/kg
Power-density	<0.1 kW/kg	>1 kW/kg	0.1 kW/kg

Application Examples

In general Double-Layer Capacitors are applied for voltage support, for saving or for replacing conventional battery or charger solutions. The typical application is the quick supply of several 100A to 1000A in the direct current field.

Slip Control in Wind Power

In large-scale wind turbine systems, slip controllers are used to control the rotation speed by altering the angle of the rotor blades. The drives are mains-independent and if electrically controlled use the energy stored in batteries or double-layer capacitors. These storage devices have to meet stringent requirements. During winter time the temperatures in the wind tower top housing often reach around -40°C, and during summer time they may easily go up to more than +60°C during operation. The current of 200A necessary for the breakaway torque of e.g. a 3 kW motor presents big problems to batteries due to the ambient conditions described. Their short life time and frequently necessary maintenance renders them unsatisfactory. However, when properly dimensioned, modern SuperCap solutions enable a maintenance-free usage of the electrical storage device of minimum 10 years.

Start of Micro-Turbines, Fuel Cells or Diesel-Electric Generator working as Power Set

For micro-turbines driven with natural gas for generation of electrical energy on oil platforms, in part also for gas pumping stations, in sensible areas like hospitals and huge factories the use of SuperCap modules to replace conventional starter batteries (by experience needing replacement every 2 to 3 years) is the optimum choice. Usually about 300 kJ of electrical energy at a system voltage of 240V are needed for a turbine start-up time of 10 to 20 s.

When starting special micro-turbines or for bridging during start of a fuel cell working as emergency power supply, generally a few 100kJ of electrical energy are required for a system start time of approx. 10 to 20 sec. The stored energy time is approximately 20 s. Due to the system voltage of 48V, 22 cells of 1200F are cascaded in a

module to achieve the setpoint voltage in order to replace a battery block.

For start-up of generators for energy supply of autonomous telecommunication stations which are located decentrally in a tight network but supplied with fuel the new double-layer capacitors would provide a solution. Right now tests are run with 14V series connections (70 to 100F) which should render a maintenance-free service. After three starting processes in a sequence their energy with 300 to 500A each flowing (depending on the size of the motor) is used up. The now running generator, however, immediately supplies them with electrical energy again.

Starting huge Railway, Naval or Truck Motors

The start of V16 or V24 cylinder motors (6000 kW), e.g. for generator drives of diesel-electric trains or start of a naval diesel engine requires considerably high currents. 1300A are quite usual which can be covered by capacitor units of 450 to 600 F at 28 V. Frequently the crankshaft is turned by two starters on both sides (e.g. 7 kW each with a positive switch off after 9 s for 2 min), in order to avoid torsion of the huge mass. The low total internal resistance of less than 3 m Ω which is beyond reach for batteries the capacitor solution is outstanding.

Recuperation of Braking Energy

In times of resource shortage of fuel the highest possible recuperation of braking energy is a challenging aim. While recuperation in electric train drives or in hybrid busses is already practiced since long, for non-mains connected vehicles the energy recuperation to the on-board battery has only be realized to the extent of few per cent. The basic reason is the charge current limitation of batteries where the recuperable energy is obtained at very high currents in a scope of milliseconds. If for example 1 ton shall be decelerated from 100 km/h to 0 km/h 400 kJ are released, for 10 tons it is ten times as much. So far no suitable high-energy storage devices were available (guideline values: 500A to 1000A). This is the domain of the new SuperCaps since in the foreseeable future even most modern battery systems will not be in a position to cope with such energy.



A WIMA part number consists of 18 digits and is composed as follows:

- Field 1 - 4: Type description
- Field 5 - 6: Rated voltage
- Field 7 - 10: Capacitance
- Field 11 - 12: Size and PCM
- Field 13 - 14: Special features (e.g. Snubber versions)
- Field 15: Capacitance tolerance
- Field 16: Packing
- Field 17 - 18: Lead length (untaped)

1	2	3	4	5	6	7	8	9	10	11	12	13	14	15	16	17	18
M	K	S	2	C	0	3	1	0	0	1	A	0	0	M	S	S	D
MKS 2				63 VDC		0.01 µF			2.5x6.5x7.2			-		20%	bulk	6-2	

<p>Type description:</p> <p>SMD-PET = SMDT SMD-PEN = SMDN SMD-PPS = SMDI FKP 02 = FKS0 MKS 02 = MKS0 FKS 2 = FKS2 FKM 2 = FKM2 FKP 2 = FKP2 MKS 2 = MKS2 MKP 2 = MKP2 MKI 2 = MKI2 FKS 3 = FKS3 FKM 3 = FKM3 FKP 3 = FKP3 MKS 4 = MKS4 MKM 4 = MKM4 MKP 4 = MKP4 MKP 10 = MKP1 FKP 4 = FKP4 FKP 1 = FKP1 MKP-X2 = MKX2 MKP-X2 R = MKXR MKP-Y2 = MKY2 MP 3-X2 = MPX2 MP 3-X1 = MPX1 MP 3-Y2 = MPY2 MP 3R-Y2 = MPYR Snubber FKP = SNFF Snubber MKP = SNMP GTO MKP = GTOM DC-LINK MKP 4 = DCP4 DC-LINK MKP C = DCPC DC-LINK HC = DCH_ SuperCap C = SCSC SuperCap MC = SCMC SuperCap R = SCSR SuperCap MR = SCMR</p>	<p>Rated voltage:</p> <p>16 VDC = A0 2.5 VDC = A1 4 VDC = A2 14 VDC = A3 28 VDC = A4 40 VDC = A5 50 VDC = B0 63 VDC = C0 100 VDC = D0 160 VDC = E0 250 VDC = F0 400 VDC = G0 630 VDC = J0 800 VDC = L0 850 VDC = M0 1000 VDC = O1 1200 VDC = Q0 1600 VDC = T0 2000 VDC = U0 2500 VDC = V0 4000 VDC = X0 6000 VDC = Y0 250 VAC = 0W 275 VAC = 1W 300 VAC = 2W 400 VAC = 3W 440 VAC = 4W 500 VAC = 5W ...</p>	<p>Capacitance:</p> <p>22 pF = 0022 47 pF = 0047 100 pF = 0100 220 pF = 0220 470 pF = 0470 1000 pF = 1100 2200 pF = 1220 4700 pF = 1470 0.01 µF = 2100 0.022 µF = 2220 0.047 µF = 2470 0.1 µF = 3100 0.22 µF = 3220 0.47 µF = 3470 1 µF = 4100 2.2 µF = 4220 4.7 µF = 4470 10 µF = 5100 22 µF = 5220 47 µF = 5470 100 µF = 6100 220 µF = 6220 1 F = A010 2.5 F = A025 50 F = A500 100 F = B100 600 F = B600 1200 F = C120 ...</p>	<p>Size:</p> <p>4.8x3.3x3 Size 1812 = X1 5.7x5.1x3.5 Size 2220 = Y1 7.2x6.1x3 Size 2824 = T1 2.5x7x4.6 PCM2.5 = 0B 3x7.5x4.6 PCM2.5 = 0C 2.5x6.5x7.2 PCM5 = 1A 3x7.5x7.2 PCM5 = 1B 2.5x7x10 PCM7.5 = 2A 3x8.5x10 PCM7.5 = 2B 3x9x13 PCM10 = 3A 4x9x13 PCM10 = 3B 5x11x18 PCM15 = 4A 6x12.5x18 PCM15 = 4B 5x14x26.5 PCM22.5 = 5A 6x15x26.5 PCM22.5 = 5B 9x19x31.5 PCM27.5 = 6A 11x21x31.5 PCM27.5 = 6B 9x19x41.5 PCM37.5 = 7A 11x22x41.5 PCM37.5 = 7B 94x49x182 DCH_ = H0 94x77x182 DCH_ = H1 ...</p> <p>Special features:</p> <p>Standard = 00 Version A1 = 1A Version A1.1 = 1B ...</p>	<p>Tolerance:</p> <p>20% = M 10% = K 5% = J 2.5% = H 1% = E ...</p> <p>Packing:</p> <p>AMMO H16.5 340x340 = A AMMO H16.5 490x370 = B AMMO H18.5 340x340 = C AMMO H18.5 490x370 = D REEL H16.5 360 = F REEL H16.5 500 = H REEL H18.5 360 = I REEL H18.5 500 = J ROLL H16.5 = N ROLL H18.5 = O BLISTER W12 180 = P BLISTER W12 180 = Q BLISTER W12 180 = R BLISTER W12 180 = T Bulk Mini = M Bulk Standard = S Bulk Maxi = G TPS Mini = X TPS Standard = Y ...</p> <p>Lead length (untaped)</p> <p>3.5 ±0.5 = C9 6-2 = SD 16-1 = P4 ...</p>
---	--	--	--	---

The data on this page is not complete and serves only to explain the part number system. Part number information is listed on the pages of the respective WIMA range.