

## HIGH OUTPUT CURRENT C-MOS 3-TERMINAL VOLTAGE REGULATOR

### ■ GENERAL DESCRIPTION

The **NJU7202 series** is a high output current C-MOS 3-terminal positive voltage regulator which contains internal accurate voltage reference, error amplifier, control transistor, output voltage setting resistor and short current protection circuit.

The regulation voltage is fixed by internal circuits and the following line-up of different output voltage versions are available.

The short current protection circuit prevents destruction of a element by careless great current output in short circuit.

The **NJU7202 series** is suitable for battery operated items and battery back-up systems because of low operating current and low dropout voltage.

### ■ PACKAGE OUTLINE

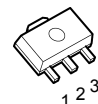

**NJU7202U** (SOT-89)

### ■ FEATURES

- High Output Current  $I_o = 100\text{mA}$
- Low Operating Current  $20\mu\text{A typ}$
- Low Dropout Voltage  $\Delta V_{I_o} < 0.6\text{V @ } I_o = 100\text{mA}$
- Wide Operating Voltage Range
- Small Temperature Coefficient of Output Voltage
- Short Current Protection Circuit
- Package Outline SOT-89
- C-MOS Technology

### ■ TERMINAL DESCRIPTION

No.	Description
1	GND
2	Input
3	Output

### ■ OUTPUT VOLTAGE LINE-UP

Output Voltage	SOT-89 Type
+3.0V	NJU7202U30
+3.3V	NJU7202U33
+5.0V	NJU7202U50

Note1) The SOT-89 type name is different from the marking, so it refer to attached paper correspondence table.

### ■ EQUIVALENT CIRCUIT

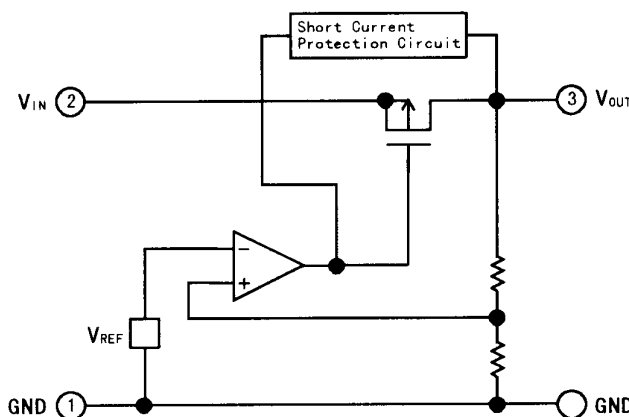

# NJU7202 Series

## ■ ABSOLUTE MAXIMUM RATINGS

( $T_a = 25^\circ\text{C}$ )

PARAMETER	SYMBOL	RATINGS	UNIT
Input Voltage	$V_{IN}$	15	V
Output Voltage	$V_{OUT}$	GND-0.3 to $V_{IN}+0.3$	V
Output Current	$I_{OUT}$	200	mA
Power Dissipation	$P_D$	300 (SOT-89)	mW
Operating Temperature	$T_{opr}$	-25 to +75	$^\circ\text{C}$
Storage Temperature	$T_{stg}$	-40 to +125	$^\circ\text{C}$

## ■ ELECTRICAL CHARACTERISTICS

+3.0V Version

( $C_{IN} = C_O = 0.1\mu\text{F}$ ,  $T_a = 25^\circ\text{C}$ )

PARAMETER	SYMBOL	CONDITION	MIN.	TYP.	MAX.	UNIT
Output Voltage	$V_{OUT}$	$V_{IN} = 5.0\text{V}$ , $I_{OUT} = 70\text{mA}$	2.85	3.00	3.15	V
Dropout Voltage	$\Delta V_{IO}$	$I_{OUT} = 50\text{mA}$	-	0.4	0.6	V
Input Voltage	$V_{IN}$		-	-	14	V
Operating Current	$I_{DD1}$	$V_{IN} = 5.0\text{V}$	-	20	30	$\mu\text{A}$
Load Regulation	$\frac{\Delta V_{OUT}}{\Delta I_{OUT}}$	$V_{IN} = 5.0\text{V}$ , $I_{OUT} = 1$ to $100\text{mA}$	-	120	160	mV
Line Regulation	$\frac{\Delta V_{OUT}}{\Delta V_{IN} \cdot V_{OUT}}$	$V_{IN} = 4.0$ to $12.0\text{V}$	-	0.1	-	%/V

+3.3V Version

( $C_{IN} = C_O = 0.1\mu\text{F}$ ,  $T_a = 25^\circ\text{C}$ )

PARAMETER	SYMBOL	CONDITION	MIN.	TYP.	MAX.	UNIT
Output Voltage	$V_{OUT}$	$V_{IN} = 5.3\text{V}$ , $I_{OUT} = 70\text{mA}$	3.135	3.300	3.465	V
Dropout Voltage	$\Delta V_{IO}$	$I_{OUT} = 50\text{mA}$	-	0.4	0.6	V
Input Voltage	$V_{IN}$		-	-	14	V
Operating Current	$I_{DD1}$	$V_{IN} = 5.3\text{V}$	-	20	30	$\mu\text{A}$
Load Regulation	$\frac{\Delta V_{OUT}}{\Delta I_{OUT}}$	$V_{IN} = 5.3\text{V}$ , $I_{OUT} = 1$ to $100\text{mA}$	-	120	160	mV
Line Regulation	$\frac{\Delta V_{OUT}}{\Delta V_{IN} \cdot V_{OUT}}$	$V_{IN} = 4.3$ to $12.0\text{V}$	-	0.1	-	%/V

+5.0V Version

( $C_{IN} = C_O = 0.1\mu\text{F}$ ,  $T_a = 25^\circ\text{C}$ )

PARAMETER	SYMBOL	CONDITION	MIN.	TYP.	MAX.	UNIT
Output Voltage	$V_{OUT}$	$V_{IN} = 7.0\text{V}$ , $I_{OUT} = 70\text{mA}$	4.75	5.00	5.25	V
Dropout Voltage	$\Delta V_{IO}$	$I_{OUT} = 100\text{mA}$	-	0.3	0.6	V
Input Voltage	$V_{IN}$		-	-	14	V
Operating Current	$I_{DD1}$	$V_{IN} = 7.0\text{V}$	-	20	30	$\mu\text{A}$
Load Regulation	$\frac{\Delta V_{OUT}}{\Delta I_{OUT}}$	$V_{IN} = 7.0\text{V}$ , $I_{OUT} = 1$ to $100\text{mA}$	-	120	160	mV
Line Regulation	$\frac{\Delta V_{OUT}}{\Delta V_{IN} \cdot V_{OUT}}$	$V_{IN} = 6.0$ to $12.0\text{V}$	-	0.1	-	%/V

## ■ MEASUREMENT CIRCUIT

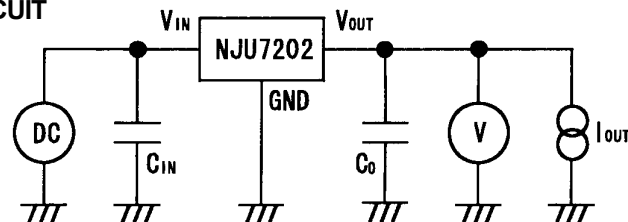

[CAUTION]  
The specifications on this databook are only given for information, without any guarantee as regards either mistakes or omissions. The application circuits in this databook are described only to show representative usages of the product and not intended for the guarantee or permission of any right including the industrial rights.