

Features

- High Performance, Low Power AVR[®]32 UC 32-Bit Microcontroller
 - Compact Single-Cycle RISC Instruction Set Including DSP Instruction Set
 - Read-Modify-Write Instructions and Atomic Bit Manipulation
 - Performing 1.49DMIPS/MHz
 - Up to 91 DMIPS Running at 66MHz from Flash (1 Wait-State)
 - Up to 54 DMIPS Running at 36MHz from Flash (0 Wait-State)
 - Memory Protection Unit
- Multi-Layer Bus System
 - High-Performance Data Transfers on Separate Buses for Increased Performance
 - 8 Peripheral DMA Channels (PDCA) Improves Speed for Peripheral Communication
 - 4 generic DMA Channels for High Bandwidth Data Paths
- Internal High-Speed Flash
 - 256KBytes, 128KBytes, 64KBytes versions
 - Single-Cycle Flash Access up to 36MHz
 - Prefetch Buffer Optimizing Instruction Execution at Maximum Speed
 - 4 ms Page Programming Time and 8ms Full-Chip Erase Time
 - 100,000 Write Cycles, 15-year Data Retention Capability
 - Flash Security Locks and User Defined Configuration Area
- Internal High-Speed SRAM
 - 64KBytes Single-Cycle Access at Full Speed, Connected to CPU Local Bus
 - 64KBytes on the Multi-Layer Bus System
- Interrupt Controller
 - Autovectored Low Latency Interrupt Service with Programmable Priority
- System Functions
 - Power and Clock Manager Including Internal RC Clock and One 32KHz Oscillator
 - Two Multipurpose Oscillators and Two Phase-Lock-Loop (PLL),
 - Watchdog Timer, Real-Time Clock Timer
- External Memories
 - Support SDRAM, SRAM, NandFlash (1-bit and 4-bit ECC), Compact Flash
 - Up to 66 MHz
- External Storage device support
 - MultiMediaCard (MMC), Secure-Digital (SD), SDIO V1.1
 - CE-ATA, FastSD, SmartMedia, Compact Flash
 - Memory Stick: Standard Format V1.40, PRO Format V1.00, Micro
 - IDE Interface
- One Advanced Encryption System (AES) for AT32UC3A3256S, AT32UC3A3128S and AT32UC3A364S
 - 256-, 192-, 128-bit Key Algorithm, Compliant with FIPS PUB 197 Specifications
 - Buffer Encryption/Decryption Capabilities
- Universal Serial Bus (USB)
 - High-Speed USB (480Mbit/s) Device/MiniHost with On-The-Go (OTG)
 - Flexible End-Point Configuration and Management with Dedicated DMA Channels
 - On-Chip Transceivers Including Pull-Ups
- One 8-channel 10-bit Analog-To-Digital Converter, multiplexed with Digital IOs.
- Two Three-Channel 16-bit Timer/Counter (TC)
- Four Universal Synchronous/Asynchronous Receiver/Transmitters (USART)
 - Independent Baudrate Generator, Support for SPI, IrDA and ISO7816 interfaces



AVR[®]32 32-Bit Microcontroller

AT32UC3A3256S
AT32UC3A3256
AT32UC3A3128S
AT32UC3A3128
AT32UC3A364S
AT32UC3A364

Summary

Preliminary

32072AS-AVR32-03/09



- Support for Hardware Handshaking, RS485 Interfaces and Modem Line
- Two Master/Slave Serial Peripheral Interfaces (SPI) with Chip Select Signals
- One Synchronous Serial Protocol Controller
 - Supports I2S and Generic Frame-Based Protocols
- Two Master/Slave Two-Wire Interface (TWI), 400kbit/s I2C-compatible
- On-Chip Debug System (JTAG interface)
 - Nexus Class 2+, Runtime Control, Non-Intrusive Data and Program Trace
- 110 General Purpose Input/Output (GPIOs)
 - Standard or High Speed mode
 - Toggle capability: up to 66MHz
- 144-pin TBGA and LQFP
- Single 3.3V Power Supply

1. Description

The AT32UC3A3 is a complete System-On-Chip microcontroller based on the AVR32 UC RISC processor running at frequencies up to 66MHz. AVR32 UC is a high-performance 32-bit RISC microprocessor core, designed for cost-sensitive embedded applications, with particular emphasis on low power consumption, high code density and high performance.

The processor implements a Memory Protection Unit (MPU) and a fast and flexible interrupt controller for supporting modern operating systems and real-time operating systems. Higher computation capabilities are achievable using a rich set of DSP instructions.

The AT32UC3A3 incorporates on-chip Flash and SRAM memories for secure and fast access.

The Peripheral Direct Memory Access Controller (PDCA) enables data transfers between peripherals and memories without processor involvement. The PDCA drastically reduces processing overhead when transferring continuous and large data streams.

The Direct Memory Access controller (DMACA) allows high bandwidth data flows between high speed peripherals (USB, External Memories, MMC, SDIO, ...) and through high speed internal features (AES, internal memories).

The Power Manager improves design flexibility and security: the on-chip Brown-Out Detector monitors the power supply, the CPU runs from the on-chip RC oscillator or from one of external oscillator sources, a Real-Time Clock and its associated timer keeps track of the time.

The Device includes two sets of three identical 16-bit Timer/Counter (TC) channels. Each channel can be independently programmed to perform frequency measurement, event counting, interval measurement, pulse generation, delay timing and pulse width modulation. 16-bit channels are combined to operate as 32-bit channels.

The AT32UC3A3 also features many communication interfaces for communication intensive applications like UART, SPI or TWI. Additionally, a flexible Synchronous Serial Controller (SSC) and an USB are available.

The SSC provides easy access to serial communication protocols and audio standards like I2S.

The High-Speed (480MBit/s) USB 2.0 Device interface supports several USB Classes at the same time thanks to the rich Endpoint configuration. The On-The-Go (OTG) Host interface allows device like a USB Flash disk or a USB printer to be directly connected to the processor.

AT32UC3A3 integrates a class 2+ Nexus 2.0 On-Chip Debug (OCD) System, with non-intrusive real-time trace, full-speed read/write memory access in addition to basic runtime control.

2. Blockdiagram

Figure 2-1. Blockdiagram

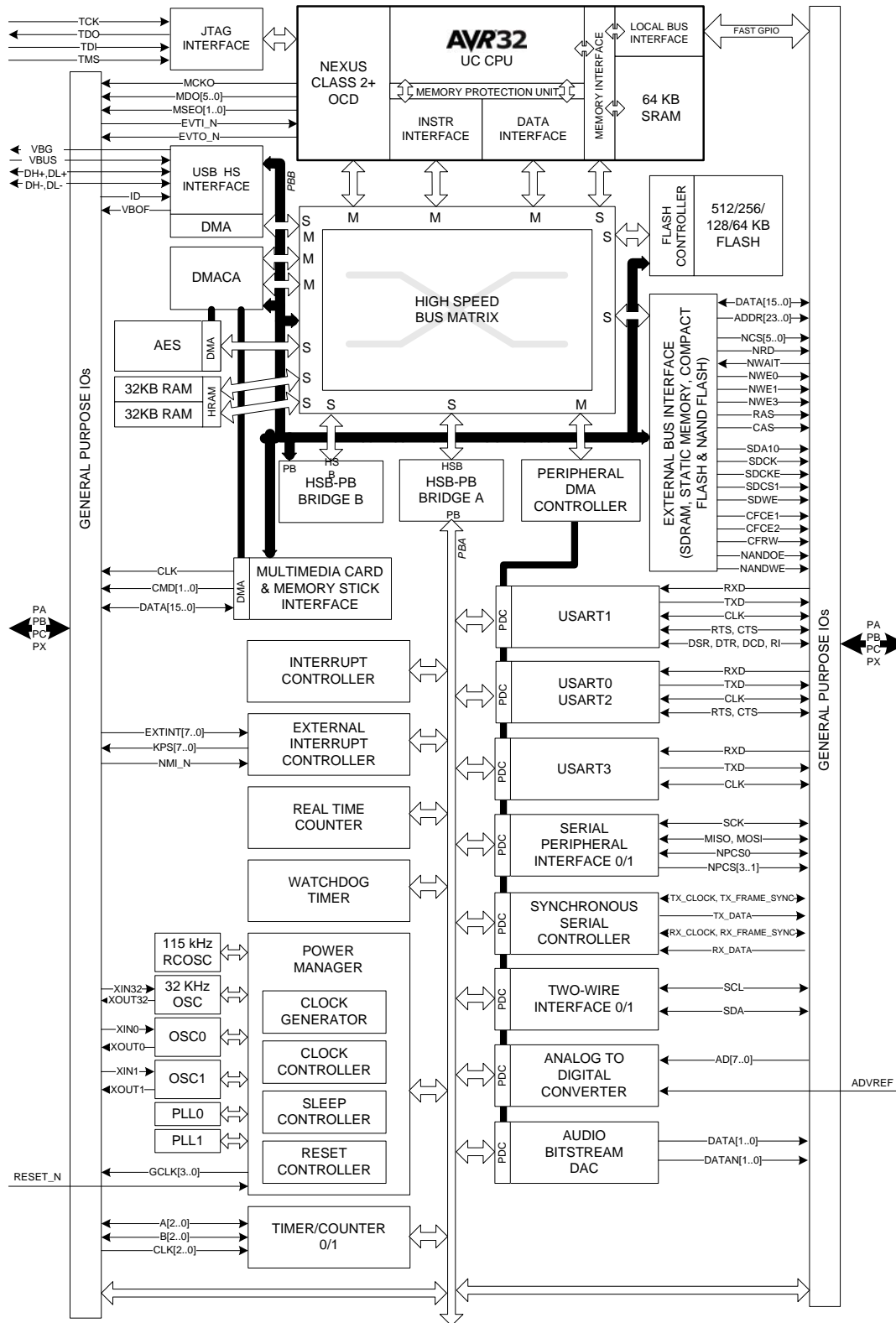

2.1 Processor and Architecture

2.1.1 AVR32 UC CPU

- 32-bit load/store AVR32A RISC architecture
 - 15 general-purpose 32-bit registers
 - 32-bit Stack Pointer, Program Counter and Link Register reside in register file
 - Fully orthogonal instruction set
 - Privileged and unprivileged modes enabling efficient and secure Operating Systems
 - Innovative instruction set together with variable instruction length ensuring industry leading code density
 - DSP extension with saturating arithmetic, and a wide variety of multiply instructions
- Three stage pipeline allows one instruction per clock cycle for most instructions
 - Byte, halfword, word and double word memory access
 - Multiple interrupt priority levels
- MPU allows for operating systems with memory protection

2.1.2 Debug and Test System

- IEEE1149.1 compliant JTAG and boundary scan
- Direct memory access and programming capabilities through JTAG interface
- Extensive On-Chip Debug features in compliance with IEEE-ISTO 5001-2003 (Nexus 2.0) Class 2+
 - Low-cost NanoTrace supported
- Auxiliary port for high-speed trace information
- Hardware support for six Program and two data breakpoints
- Unlimited number of software breakpoints supported
- Advanced Program, Data, Ownership and Watchpoint trace supported

2.1.3 Peripheral DMA Controller

- Transfers from/to peripheral to/from any memory space without intervention of the processor
- Next Pointer Support, forbids strong real-time constraints on buffer management
- Eight channels and 24 Handshake interfaces
 - Two for each USART
 - Two for each Serial Synchronous Controller (SSC)
 - Two for each Serial Peripheral Interface (SPI)
 - One for ADC
 - Four for each TWI Interface
 - Two for each Audio Bit Stream DAC

2.1.4 Bus System

- High Speed Bus (HSB) matrix with 7 Masters and 10 Slaves handled
 - Handles Requests from
 - Masters: the CPU (Instruction and Data Fetch), PDCA, CPU SAB, USBB, DMACA
 - Slaves: the internal Flash, internal SRAM, Peripheral Bus A, Peripheral Bus B, External Bus Interface (EBI), Advanced Encryption Standard (AES)
 - Round-Robin Arbitration (three modes supported: no default master, last accessed default master, fixed default master)
 - Burst breaking with Slot Cycle Limit
 - One address decoder provided per master
- Peripheral Bus A able to run on at divided bus speeds compared to the High Speed Bus

3. Signals Description

The following table gives details on the signal name classified by peripheral

Table 3-1. Signal Description List

Signal Name	Function	Type	Active Level	Comments
Power				
VDDIO	I/O Power Supply	Power		3.0 to 3.6 V
VDDANA	Analog Power Supply	Power		3.0 to 3.6 V
VDDIN	Voltage Regulator Input Supply	Power		2.7 to 3.6 V
ONREG	Voltage Regulator ON/OFF	Power Control	1	2.7 to 3.6 V
VDDCORE	Voltage Regulator Output for Digital Supply	Power Output		1.65 to 1.95V
GNDANA	Analog Ground	Ground		
GNDIO	I/O Ground	Ground		
GNDCORE	Digital Ground	Ground		
GNDPLL	PLL Ground	Ground		
Clocks, Oscillators, and PLL's				
XIN0, XIN1, XIN32	Crystal 0, 1, 32 Input	Analog		
XOUT0, XOUT1, XOUT32	Crystal 0, 1, 32 Output	Analog		
JTAG				
TCK	Test Clock	Input		
TDI	Test Data In	Input		
TDO	Test Data Out	Output		
TMS	Test Mode Select	Input		
Auxiliary Port - AUX				
MCKO	Trace Data Output Clock	Output		
MDO[5:0]	Trace Data Output	Output		
MSEO[1:0]	Trace Frame Control	Output		
EVTI_N	Event In	Output	Low	
EVTO_N	Event Out	Output	Low	
Power Manager - PM				

Table 3-1. Signal Description List

Signal Name	Function	Type	Active Level	Comments
GCLK[2:0]	Generic Clock Pins	Output		
RESET_N	Reset Pin	Input	Low	
DMA Controller - DMACA (optional)				
DMAACK[1:0]	DMA Acknowledge	Output		
DMARQ[1:0]	DMA Requests	Input		
External Interrupt Module - EIM				
EXTINT[7:0]	External Interrupt Pins	Input		
KPS0 - KPS7	Keypad Scan Pins	Output		
NMI_N	Non-Maskable Interrupt Pin	Input	Low	
General Purpose Input/Output pin - GPIOA, GPIOB, GPIOC, GPIOX				
PA[31:0]	Parallel I/O Controller GPIOA	I/O		
PB[11:0]	Parallel I/O Controller GPIOB	I/O		
PC[5:0]	Parallel I/O Controller GPIOC	I/O		
PX[59:0]	Parallel I/O Controller GPIO X	I/O		
External Bus Interface - EBI				
ADDR[23:0]	Address Bus	Output		
CAS	Column Signal	Output	Low	
CFCE1	Compact Flash 1 Chip Enable	Output	Low	
CFCE2	Compact Flash 2 Chip Enable	Output	Low	
CFRNW	Compact Flash Read Not Write	Output		
DATA[15:0]	Data Bus	I/O		
NANDOE	NAND Flash Output Enable	Output	Low	
NANDWE	NAND Flash Write Enable	Output	Low	
NCS[5:0]	Chip Select	Output	Low	
NRD	Read Signal	Output	Low	
NWAIT	External Wait Signal	Input	Low	
NWE0	Write Enable 0	Output	Low	
NWE1	Write Enable 1	Output	Low	

Table 3-1. Signal Description List

Signal Name	Function	Type	Active Level	Comments
RAS	Row Signal	Output	Low	
SDA10	SDRAM Address 10 Line	Output		
SDCK	SDRAM Clock	Output		
SDCKE	SDRAM Clock Enable	Output		
SDCS	SDRAM Chip Select	Output	Low	
SDWE	SDRAM Write Enable	Output	Low	
MultiMedia Card Interface - MCI				
CLK	Multimedia Card Clock	Output		
CMD[1:0]	Multimedia Card Command	I/O		
DATA[15:0]	Multimedia Card Data	I/O		
Serial Peripheral Interface - SPI0				
MISO	Master In Slave Out	I/O		
MOSI	Master Out Slave In	I/O		
NPCS[3:0]	SPI Peripheral Chip Select	I/O	Low	
SCK	Clock	Output		
Synchronous Serial Controller - SSC				
RX_CLOCK	SSC Receive Clock	I/O		
RX_DATA	SSC Receive Data	Input		
RX_FRAME_SYNC	SSC Receive Frame Sync	I/O		
TX_CLOCK	SSC Transmit Clock	I/O		
TX_DATA	SSC Transmit Data	Output		
TX_FRAME_SYNC	SSC Transmit Frame Sync	I/O		
Timer/Counter - TC0, TC1				
A0	Channel 0 Line A	I/O		
A1	Channel 1 Line A	I/O		
A2	Channel 2 Line A	I/O		
B0	Channel 0 Line B	I/O		
B1	Channel 1 Line B	I/O		

Table 3-1. Signal Description List

Signal Name	Function	Type	Active Level	Comments
B2	Channel 2 Line B	I/O		
CLK0	Channel 0 External Clock Input	Input		
CLK1	Channel 1 External Clock Input	Input		
CLK2	Channel 2 External Clock Input	Input		
Two-wire Interface - TWI0, TWI1				
SCL	Serial Clock	I/O		
SDA	Serial Data	I/O		
Universal Synchronous Asynchronous Receiver Transmitter - USART0, USART1, USART2, USART3				
CLK	Clock	I/O		
CTS	Clear To Send	Input		
DCD	Data Carrier Detect			Only USART1
DSR	Data Set Ready			Only USART1
DTR	Data Terminal Ready			Only USART1
RI	Ring Indicator			Only USART1
RTS	Request To Send	Output		
RXD	Receive Data	Input		
RXDN	Inverted Receive Data	Input	Low	
TXD	Transmit Data	Output		
TXDN	Inverted Transmit Data	Output	Low	
Analog to Digital Converter - ADC				
AD0 - AD7	Analog input pins	Analog input		
Audio Bitstream DAC (ABDAC)				
DATA0-DATA1	D/A Data out	Output		
DATAN0-DATAN1	D/A Data inverted out	Output		
Universal Serial Bus Device - USB				
FSDM	USB Full Speed Data -	Analog		
FSDP	USB Full Speed Data +	Analog		
HSDM	USB High Speed Data -	Analog		

Table 3-1. Signal Description List

Signal Name	Function	Type	Active Level	Comments
HSDP	USB High Speed Data +	Analog		
USB_VBIAS	USB VBIAS reference	Analog		Connect to the ground through a 6810ohms (+/- 0.5%) resistor
USB_VBUS	USB VBUS for OTG feature	Output		

4. Package and Pinout

4.1 Package

The device pins are multiplexed with peripheral functions as described in the Peripheral Multiplexing on I/O Line section.

Figure 4-1. TBGA144 Pinout (top view)

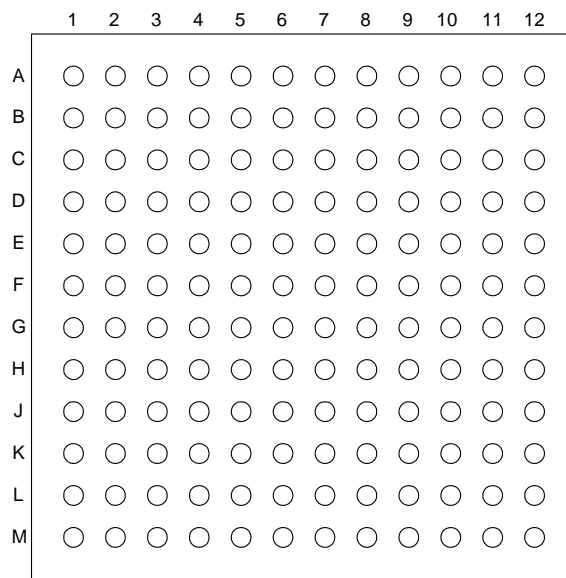

Table 4-1. BGA144 Package Pinout A1..M8

	1	2	3	4	5	6	7	8	9	10	11	12
A	PX40	PB00	PA28	PA27	PB03	PA29	PC02	PC04	PC05	DPHS	DMHS	USB_VBUS
B	PX10	PB11	PA31	PB02	VDDIO	PB04	PC03	VDDIO	USB_VBIAS	DMFS	GNDPLL	PA09
C	PX09	PX35	GNDIO	PB01	PX16	PX13	PA30	PB08	DPFS	GNDCORE	PA08	PA10
D	PX08	PX37	PX36	PX47	PX19	PX12	PB10	PA02	PA26	PA11	PB07	PB06
E	PX38	VDDIO	PX54	PX53	VDDIO	PX15	PB09	VDDIN	PA25	PA07	VDDCORE	PA12
F	PX39	PX07	PX06	PX49	PX48	GNDIO	GNDIO	PA06	PA04	PA05	PA13	PA16
G	PX00	PX05	PX59	PX50	PX51	GNDIO	GNDIO	PA23	PA24	PA03	PA00	PA01
H	PX01	VDDIO	PX58	PX57	VDDIO	PC01	PA17	VDDIO	PA21	PA22	VDDANA	PB05
J	PX04	PX02	PX34	PX56	PX55	PA14	PA15	PA19	PA20	TMS	TDO	RESET_N
K	PX03	PX44	GNDIO	PX46	PC00	PX17	PX52	PA18	PX27	GNDIO	PX29	TCK
L	PX11	GNDIO	PX45	PX20	VDDIO	PX18	PX43	ONREG	PX26	PX28	GNDANA	TDI
M	PX22	PX41	PX42	PX14	PX21	PX23	PX24	PX25	PX32	PX31	PX30	PX33

Figure 4-2. LQFP144 Pinout

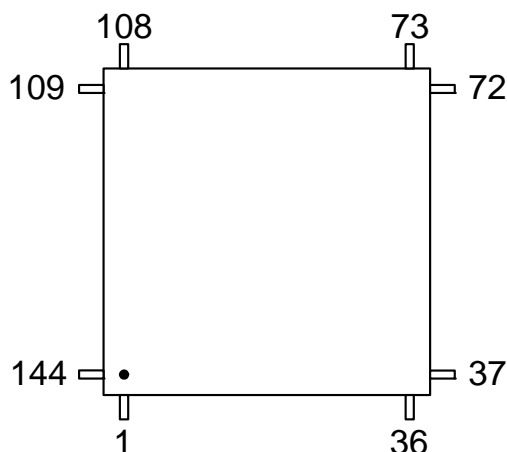

Table 4-2. Package Pinout

1	USB_VBUS	37	PX10	73	PX20	109	PA21
2	VDDIO	38	PX35	74	PX46	110	PA22
3	USB_VBIAS	39	PX47	75	PX50	111	PA23
4	GNDIO	40	PX15	76	PX57	112	PA24
5	DMHS	41	PX48	77	PX51	113	PA20
6	DPHS	42	PX53	78	PX56	114	PA19
7	GNDIO	43	PX49	79	PX55	115	PA18
8	DMFS	44	PX36	80	PX21	116	PA17
9	DPFS	45	PX37	81	VDDIO	117	GNDANA
10	VDDIO	46	PX54	82	GNDIO	118	VDDANA
11	PB08	47	GNDIO	83	PX17	119	PA25
12	PC05	48	VDDIO	84	PX18	120	PA26
13	PC04	49	PX09	85	PX23	121	PB05
14	PA30	50	PX08	86	PX24	122	PA00
15	PA02	51	PX38	87	PX52	123	PA01
16	PB10	52	PX39	88	PX43	124	PA05
17	PB09	53	PX06	89	PX27	125	PA03
18	PC02	54	PX07	90	PX26	126	PA04
19	PC03	55	PX00	91	PX28	127	PA06
20	GNDIO	56	PX59	92	PX25	128	PA16
21	VDDIO	57	PX58	93	PX32	129	PA13
22	PB04	58	PX05	94	PX29	130	VDDIO
23	PA29	59	PX01	95	PX33	131	GNDIO
24	PB03	60	PX04	96	PX30	132	PA12
25	PB02	61	PX34	97	PX31	133	PA07
26	PA27	62	PX02	98	PC00	134	PB06

Table 4-2. Package Pinout

27	PB01	63	PX03	99	PC01	135	PB07
28	PA28	64	VDDIO	100	PA14	136	PA11
29	PA31	65	GNDIO	101	PA15	137	PA08
30	PB00	66	PX44	102	GNDIO	138	PA10
31	PB11	67	PX11	103	VDDIO	139	PA09
32	PX16	68	PX14	104	TMS	140	GNDCORE
33	PX13	69	PX42	105	TDO	141	VDDCORE
34	PX12	70	PX45	106	RESET_N	142	VDDIN
35	PX19	71	PX41	107	TCK	143	ONREG
36	PX40	72	PX22	108	TDI	144	GNDPLL

4.2 Peripheral Multiplexing on I/O lines

Each GPIO line can be assigned to one of 4 peripheral functions; A, B, C, or D. The following table define how the I/O lines on the peripherals A, B, C, or D are multiplexed by the GPIO.

Table 4-3. GPIO Controller Function Multiplexing

BGA144	QFP144	PIN	GPIO Pin	Function A	Function B	Function C	Function D
G11	122	PA00	GPIO 0	USART0 - RTS	TC0 - CLK1	SPI1 - NPCS[3]	
G12	123	PA01	GPIO 1	USART0 - CTS	TC0 - A1	USART2 - RTS	
D8	15	PA02	GPIO 2	USART0 - CLK	TC0 - B1	SPI0 - NPCS[0]	
G10	125	PA03	GPIO 3	USART0 - RXD	EIC - EXTINT[4]	DAC - DATA[0]	
F9	126	PA04	GPIO 4	USART0 - TXD	EIC - EXTINT[5]	DAC - DATAN[0]	
F10	124	PA05	GPIO 5	USART1 - RXD	TC1 - CLK0	USB - USB_ID	
F8	127	PA06	GPIO 6	USART1 - TXD	TC1 - CLK1	USB - USB_VBOF	
E10	133	PA07	GPIO 7	SPI0 - NPCS[3]	DAC - DATAN[0]	USART1 - CLK	
C11	137	PA08	GPIO 8	SPI0 - SCK	DAC - DATA[0]	TC1 - B1	
B12	139	PA09	GPIO 9	SPI0 - NPCS[0]	EIC - EXTINT[6]	TC1 - A1	
C12	138	PA10	GPIO 10	SPI0 - MOSI	USB - USB_VBOF	TC1 - B0	
D10	136	PA11	GPIO 11	SPI0 - MISO	USB - USB_ID	TC1 - A2	
E12	132	PA12	GPIO 12	USART1 - CTS	SPI0 - NPCS[2]	TC1 - A0	
F11	129	PA13	GPIO 13	USART1 - RTS	SPI0 - NPCS[1]	EIC - EXTINT[7]]
J6	100	PA14	GPIO 14	SPI0 - NPCS[1]	TWIMS0 - TWALM	TWIMS1 - TWCK	
J7	101	PA15	GPIO 15	MCI - CMD[1]	SPI1 - SCK	TWIMS1 - TWD	
F12	128	PA16	GPIO 16	MCI - DATA[11]	SPI1 - MOSI	TC1 - CLK2	
H7	116	PA17	GPIO 17	MCI - DATA[10]	SPI1 - NPCS[1]	ADC - AD[7]	
K8	115	PA18	GPIO 18	MCI - DATA[9]	SPI1 - NPCS[2]	ADC - AD[6]	
J8	114	PA19	GPIO 19	MCI - DATA[8]	SPI1 - MISO	ADC - AD[5]	

Table 4-3. GPIO Controller Function Multiplexing

J9	113	PA20	GPIO 20	EIC - EXTINT[8]	SSC - RX_FRAME_SYNC	ADC - AD[4]	
H9	109	PA21	GPIO 21	ADC - AD[0]	EIC - EXTINT[0]	USB - USB_ID	
H10	110	PA22	GPIO 22	ADC - AD[1]	EIC - EXTINT[1]	USB - USB_VBOF	
G8	111	PA23	GPIO 23	ADC - AD[2]	EIC - EXTINT[2]	DAC - DATA[1]	
G9	112	PA24	GPIO 24	ADC - AD[3]	EIC - EXTINT[3]	DAC - DATAN[1]	
E9	119	PA25	GPIO 25	TWIMS0 - TWD	TWIMS1 - TWALM	USART1 - DCD	
D9	120	PA26	GPIO 26	TWIMS0 - TWCK	USART2 - CTS	USART1 - DSR	
A4	26	PA27	GPIO 27	MCI - CLK	SSC - RX_DATA	USART3 - RTS	MSI - SCLK
A3	28	PA28	GPIO 28	MCI - CMD[0]	SSC - RX_CLOCK	USART3 - CTS	MSI - BS
A6	23	PA29	GPIO 29	MCI - DATA[0]	USART3 - TXD	TC0 - CLK0	MSI - DATA[0]
C7	14	PA30	GPIO 30	MCI - DATA[1]	USART3 - CLK	DMACA - DMAACK[0]	MSI - DATA[1]
B3	29	PA31	GPIO 31	MCI - DATA[2]	USART2 - RXD	DMACA - DMARQ[0]	MSI - DATA[2]
A2	30	PB00	GPIO 32	MCI - DATA[3]	USART2 - TXD	ADC - TRIGGER	MSI - DATA[3]
C4	27	PB01	GPIO 33	MCI - DATA[4]	DAC - DATA[1]	EIC - SCAN[0]	MSI - INS
B4	25	PB02	GPIO 34	MCI - DATA[5]	DAC - DATAN[1]	EIC - SCAN[1]	
A5	24	PB03	GPIO 35	MCI - DATA[6]	USART2 - CLK	EIC - SCAN[2]	
B6	22	PB04	GPIO 36	MCI - DATA[7]	USART3 - RXD	EIC - SCAN[3]	
H12	121	PB05	GPIO 37	USB - USB_ID	TC0 - A0	EIC - SCAN[4]	
D12	134	PB06	GPIO 38	USB - USB_VBOF	TC0 - B0	EIC - SCAN[5]	
D11	135	PB07	GPIO 39	SPI1 - SCK	SSC - TX_CLOCK	EIC - SCAN[6]	
C8	11	PB08	GPIO 40	SPI1 - MISO	SSC - TX_DATA	EIC - SCAN[7]	
E7	17	PB09	GPIO 41	SPI1 - NPCS[0]	SSC - RX_DATA	EBI - NCS[4]	
D7	16	PB10	GPIO 42	SPI1 - MOSI	SSC - RX_FRAME_SYNC	EBI - NCS[5]	
B2	31	PB11	GPIO 43	USART1 - RXD	SSC - TX_FRAME_SYNC	PM - GCLK[1]	
K5	98	PC00	GPIO 45				
H6	99	PC01	GPIO 46				
A7	18	PC02	GPIO 47				
B7	19	PC03	GPIO 48				
A8	13	PC04	GPIO 49				
A9	12	PC05	GPIO 50				
G1	55	PX00	GPIO 51	EBI - DATA[10]	USART0 - RXD	USART1 - RI	
H1	59	PX01	GPIO 52	EBI - DATA[9]	USART0 - TXD	USART1 - DTR	

Table 4-3. GPIO Controller Function Multiplexing

J2	62	PX02	GPIO 53	EBI - DATA[8]	USART0 - CTS	PM - GCLK[0]	
K1	63	PX03	GPIO 54	EBI - DATA[7]	USART0 - RTS		
J1	60	PX04	GPIO 55	EBI - DATA[6]	USART1 - RXD		
G2	58	PX05	GPIO 56	EBI - DATA[5]	USART1 - TXD		
F3	53	PX06	GPIO 57	EBI - DATA[4]	USART1 - CTS		
F2	54	PX07	GPIO 58	EBI - DATA[3]	USART1 - RTS		
D1	50	PX08	GPIO 59	EBI - DATA[2]	USART3 - RXD		
C1	49	PX09	GPIO 60	EBI - DATA[1]	USART3 - TXD		
B1	37	PX10	GPIO 61	EBI - DATA[0]	USART2 - RXD		
L1	67	PX11	GPIO 62	EBI - NWE1	USART2 - TXD		
D6	34	PX12	GPIO 63	EBI - NWE0	USART2 - CTS		
C6	33	PX13	GPIO 64	EBI - NRD	USART2 - RTS		
M4	68	PX14	GPIO 65	EBI - NCS[1]		TC0 - A0	
E6	40	PX15	GPIO 66	EBI - ADDR[19]	USART3 - RTS	TC0 - B0	
C5	32	PX16	GPIO 67	EBI - ADDR[18]	USART3 - CTS	TC0 - A1	
K6	83	PX17	GPIO 68	EBI - ADDR[17]	DMACA - DMARQ[1]	TC0 - B1	
L6	84	PX18	GPIO 69	EBI - ADDR[16]	DMACA - DMAACK[1]	TC0 - A2	
D5	35	PX19	GPIO 70	EBI - ADDR[15]	EIC - SCAN[0]	TC0 - B2	
L4	73	PX20	GPIO 71	EBI - ADDR[14]	EIC - SCAN[1]	TC0 - CLK0	
M5	80	PX21	GPIO 72	EBI - ADDR[13]	EIC - SCAN[2]	TC0 - CLK1	
M1	72	PX22	GPIO 73	EBI - ADDR[12]	EIC - SCAN[3]	TC0 - CLK2	
M6	85	PX23	GPIO 74	EBI - ADDR[11]	EIC - SCAN[4]	SSC - TX_CLOCK	
M7	86	PX24	GPIO 75	EBI - ADDR[10]	EIC - SCAN[5]	SSC - TX_DATA	
M8	92	PX25	GPIO 76	EBI - ADDR[9]	EIC - SCAN[6]	SSC - RX_DATA	
L9	90	PX26	GPIO 77	EBI - ADDR[8]	EIC - SCAN[7]	SSC - RX_FRAME_SYN C	
K9	89	PX27	GPIO 78	EBI - ADDR[7]	SPI0 - MISO	SSC - TX_FRAME_SYNC	
L10	91	PX28	GPIO 79	EBI - ADDR[6]	SPI0 - MOSI	SSC - RX_CLOCK	
K11	94	PX29	GPIO 80	EBI - ADDR[5]	SPI0 - SCK		
M11	96	PX30	GPIO 81	EBI - ADDR[4]	SPI0 - NPCS[0]		
M10	97	PX31	GPIO 82	EBI - ADDR[3]	SPI0 - NPCS[1]		
M9	93	PX32	GPIO 83	EBI - ADDR[2]	SPI0 - NPCS[2]		
M12	95	PX33	GPIO 84	EBI - ADDR[1]	SPI0 - NPCS[3]		
J3	61	PX34	GPIO 85	EBI - ADDR[0]	SPI1 - MISO	PM - GCLK[0]	
C2	38	PX35	GPIO 86	EBI - DATA[15]	SPI1 - MOSI	PM - GCLK[1]	
D3	44	PX36	GPIO 87	EBI - DATA[14]	SPI1 - SCK	PM - GCLK[2]	
D2	45	PX37	GPIO 88	EBI - DATA[13]	SPI1 - NPCS[0]	PM - GCLK[3]	

Table 4-3. GPIO Controller Function Multiplexing

E1	51	PX38	GPIO 89	EBI - DATA[12]	SPI1 - NPCS[1]	USART1 - DCD	
F1	52	PX39	GPIO 90	EBI - DATA[11]	SPI1 - NPCS[2]	USART1 - DSR	
A1	36	PX40	GPIO 91	EBI - SDCS			
M2	71	PX41	GPIO 92	EBI - CAS			
M3	69	PX42	GPIO 93	EBI - RAS			
L7	88	PX43	GPIO 94	EBI - SDA10	USART1 - RI		
K2	66	PX44	GPIO 95	EBI - SDWE	USART1 - DTR		
L3	70	PX45	GPIO 96	EBI - SDCK			
K4	74	PX46	GPIO 97	EBI - SDCKE			
D4	39	PX47	GPIO 98	EBI - NANDOE	ADC - TRIGGER	MCI - DATA[11]	
F5	41	PX48	GPIO 99	EBI - ADDR[23]	USB - USB_VBOF	MCI - DATA[10]	
F4	43	PX49	GPIO 100	EBI - CFRNW	USB - USB_ID	MCI - DATA[9]	
G4	75	PX50	GPIO 101	EBI - CFCE2	TC1 - B2	MCI - DATA[8]	
G5	77	PX51	GPIO 102	EBI - CFCE1	DMACA - DMAACK[0]	MCI - DATA[15]	
K7	87	PX52	GPIO 103	EBI - NCS[3]	DMACA - DMARQ[0]	MCI - DATA[14]	
E4	42	PX53	GPIO 104	EBI - NCS[2]		MCI - DATA[13]	
E3	46	PX54	GPIO 105	EBI - NWAIT	USART3 - TXD	MCI - DATA[12]	
J5	79	PX55	GPIO 106	EBI - ADDR[22]	EIC - SCAN[3]	USART2 - RXD	
J4	78	PX56	GPIO 107	EBI - ADDR[21]	EIC - SCAN[2]	USART2 - TXD	
H4	76	PX57	GPIO 108	EBI - ADDR[20]	EIC - SCAN[1]	USART3 - RXD	
H3	57	PX58	GPIO 109	EBI - NCS[0]	EIC - SCAN[0]	USART3 - TXD	
G3	56	PX59	GPIO 110	EBI - NANDWE		MCI - CMD[1]	

4.2.1 Oscillator Pinout

Table 4-4. Oscillator Pinout

pin	pin	Pad	Oscillator pin
A7	18	PC02	xin0
A8	13	PC04	xin1
K5	98	PC00	xin32
B7	19	PC03	xout0
A9	12	PC05	xout1
H6	99	PC01	xout32

4.3 Signal Descriptions

The following table gives details on signal name classified by peripheral.

Table 4-5. Signal Description List

Signal Name	Function	Type	Active Level	Comments
Power				
VDDIO	I/O Power Supply	Power		3.0 to 3.6V
VDDANA	Analog Power Supply	Power		3.0 to 3.6V
VDDIN	Voltage Regulator Input Supply	Power		2.7 to 3.6V
ONREG	Voltage Regulator ON/OFF	Power Control	1	2.7 to 3.6 V
VDDCORE	Voltage Regulator Output for Digital Supply	Power Output		1.65 to 1.95 V
GNDANA	Analog Ground	Ground		
GNDIO	I/O Ground	Ground		
GNDCORE	Digital Ground	Ground		
GNDPLL	PLL Ground	Ground		
Clocks, Oscillators, and PLL's				
XIN0, XIN1, XIN32	Crystal 0, 1, 32 Input	Analog		
XOUT0, XOUT1, XOUT32	Crystal 0, 1, 32 Output	Analog		
JTAG				
TCK	Test Clock	Input		
TDI	Test Data In	Input		
TDO	Test Data Out	Output		
TMS	Test Mode Select	Input		
Auxiliary Port - AUX				
MCKO	Trace Data Output Clock	Output		
MDO[5:0]	Trace Data Output	Output		
MSEO[1:0]	Trace Frame Control	Output		
EVTI_N	Event In	Output	Low	
EVTO_N	Event Out	Output	Low	
Power Manager - PM				

Table 4-5. Signal Description List

Signal Name	Function	Type	Active Level	Comments
GCLK[2:0]	Generic Clock Pins	Output		
RESET_N	Reset Pin	Input	Low	
DMA Controller - DMACA (optional)				
DMAACK[1:0]	DMA Acknowledge	Output		
DMARQ[1:0]	DMA Requests	Input		
External Interrupt Module - EIM				
EXTINT[7:0]	External Interrupt Pins	Input		
KPS0 - KPS7	Keypad Scan Pins	Output		
NMI_N	Non-Maskable Interrupt Pin	Input	Low	
General Purpose Input/Output pin - GPIOA, GPIOB, GPIOC, GPIOX				
PA[31:0]	Parallel I/O Controller GPIO port A	I/O		
PB[11:0]	Parallel I/O Controller GPIO port B	I/O		
PC[5:0]	Parallel I/O Controller GPIO port C	I/O		
PX[59:0]	Parallel I/O Controller GPIO port X	I/O		
External Bus Interface - EBI				
ADDR[23:0]	Address Bus	Output		
CAS	Column Signal	Output	Low	
CFCE1	Compact Flash 1 Chip Enable	Output	Low	
CFCE2	Compact Flash 2 Chip Enable	Output	Low	
CFRNW	Compact Flash Read Not Write	Output		
DATA[15:0]	Data Bus	I/O		
NANDOE	NAND Flash Output Enable	Output	Low	
NANDWE	NAND Flash Write Enable	Output	Low	
NCS[5:0]	Chip Select	Output	Low	
NRD	Read Signal	Output	Low	
NWAIT	External Wait Signal	Input	Low	
NWE0	Write Enable 0	Output	Low	
NWE1	Write Enable 1	Output	Low	

Table 4-5. Signal Description List

Signal Name	Function	Type	Active Level	Comments
RAS	Row Signal	Output	Low	
SDA10	SDRAM Address 10 Line	Output		
SDCK	SDRAM Clock	Output		
SDCKE	SDRAM Clock Enable	Output		
SDCS	SDRAM Chip Select	Output	Low	
SDWE	SDRAM Write Enable	Output	Low	
MultiMedia Card Interface - MCI				
CLK	Multimedia Card Clock	Output		
CMD[1:0]	Multimedia Card Command	I/O		
DATA[15:0]	Multimedia Card Data	I/O		
Serial Peripheral Interface - SPI0				
MISO	Master In Slave Out	I/O		
MOSI	Master Out Slave In	I/O		
NPCS[3:0]	SPI Peripheral Chip Select	I/O	Low	
SCK	Clock	Output		
Synchronous Serial Controller - SSC				
RX_CLOCK	SSC Receive Clock	I/O		
RX_DATA	SSC Receive Data	Input		
RX_FRAME_SYNC	SSC Receive Frame Sync	I/O		
TX_CLOCK	SSC Transmit Clock	I/O		
TX_DATA	SSC Transmit Data	Output		
TX_FRAME_SYNC	SSC Transmit Frame Sync	I/O		
Timer/Counter - TC0, TC1				
A0	Channel 0 Line A	I/O		
A1	Channel 1 Line A	I/O		
A2	Channel 2 Line A	I/O		
B0	Channel 0 Line B	I/O		
B1	Channel 1 Line B	I/O		

Table 4-5. Signal Description List

Signal Name	Function	Type	Active Level	Comments
B2	Channel 2 Line B	I/O		
CLK0	Channel 0 External Clock Input	Input		
CLK1	Channel 1 External Clock Input	Input		
CLK2	Channel 2 External Clock Input	Input		
Two-wire Interface - TWI0, TWI1				
SCL	Serial Clock	I/O		
SDA	Serial Data	I/O		
Universal Synchronous Asynchronous Receiver Transmitter - USART0, USART1, USART2, USART3				
CLK	Clock	I/O		
CTS	Clear To Send	Input		
DCD	Data Carrier Detect			Only USART1
DSR	Data Set Ready			Only USART1
DTR	Data Terminal Ready			Only USART1
RI	Ring Indicator			Only USART1
RTS	Request To Send	Output		
RXD	Receive Data	Input		
RXDN	Inverted Receive Data	Input	Low	
TXD	Transmit Data	Output		
TXDN	Inverted Transmit Data	Output	Low	
Analog to Digital Converter - ADC				
AD0 - AD7	Analog input pins	Analog input		
Audio Bitstream DAC (ABDAC)				
DATA0-DATA1	D/A Data out	Output		
DATAN0-DATAN1	D/A Data inverted out	Output		
Universal Serial Bus Device - USB				
FSDM	USB Full Speed Data -	Analog		
FSDP	USB Full Speed Data +	Analog		
HSDM	USB High Speed Data -	Analog		

Table 4-5. Signal Description List

Signal Name	Function	Type	Active Level	Comments
HSDP	USB High Speed Data +	Analog		
USB_VBIAS	USB VBIAS reference	Analog		Connect to the ground through a 6810 ohms (+/- 0.5%) resistor
USB_VBUS	USB VBUS for OTG feature	Output		

4.3.1 JTAG Pins

TMS and TDI pins have pull-up resistors. TDO pin is an output, driven at up to VDDIO, and has no pull-up resistor.

4.3.2 RESET_N Pin

The RESET_N pin is a schmitt input and integrates a permanent pull-up resistor to VDDIO. As the product integrates a power-on reset cell, the RESET_N pin can be left unconnected in case no reset from the system needs to be applied to the product.

4.3.3 TWI Pins

When these pins are used for TWI, the pins are open-drain outputs with slew-rate limitation and inputs with inputs with spike filtering. When used as GPIO pins or used for other peripherals, the pins have the same characteristics as other GPIO pins.

4.3.4 GPIO Pins

All the I/O lines integrate a programmable pull-up resistor. Programming of this pull-up resistor is performed independently for each I/O line through the I/O Controller. After reset, I/O lines default as inputs with pull-up resistors disabled, except when indicated otherwise in the column "Reset State" of the I/O Controller multiplexing tables.

4.4 Power Considerations

4.4.1 Power Supplies

The AT32UC3A3 has several types of power supply pins:

- **VDDIO:** Powers I/O lines. Voltage is 3.3V nominal
- **VDDANA:** Powers the ADC Voltage and provides the ADVREF voltage is 3.3V nominal
- **VDDIN:** Input voltage for the voltage regulator. Voltage is 3.3V nominal
- **VDDCORE:** Output voltage from regulator for filtering purpose and provides the supply to the core, memories, and peripherals. Voltage is 1.8V nominal

The ground pins GNDCORE are common to VDDCORE and VDDIN. The ground pin for VDDANA is GNDANA. The ground pin for VDDIO is GNDIO.

Refer to Electrical Characteristics chapter for power consumption on the various supply pins.

4.4.2 Voltage Regulator

The AT32UC3A3 embeds a voltage regulator that converts from 3.3V to 1.8V with a load of up to 100 mA. The regulator takes its input voltage from VDDIN, and supplies the output voltage on VDDCORE and powers the core, memories and peripherals.

Adequate output supply decoupling is mandatory for VDDCORE to reduce ripple and avoid oscillations.

The best way to achieve this is to use two capacitors in parallel between VDDCORE and GNDCORE:

- One external 470pF (or 1nF) NPO capacitor (C_{OUT1}) should be connected as close to the chip as possible.
- One external 2.2μF (or 3.3μF) X7R capacitor (C_{OUT2}).

Adequate input supply decoupling is mandatory for VDDIN in order to improve startup stability and reduce source voltage drop.

The input decoupling capacitor should be placed close to the chip, e.g., two capacitors can be used in parallel (100nF NPO and 4.7μF X7R).

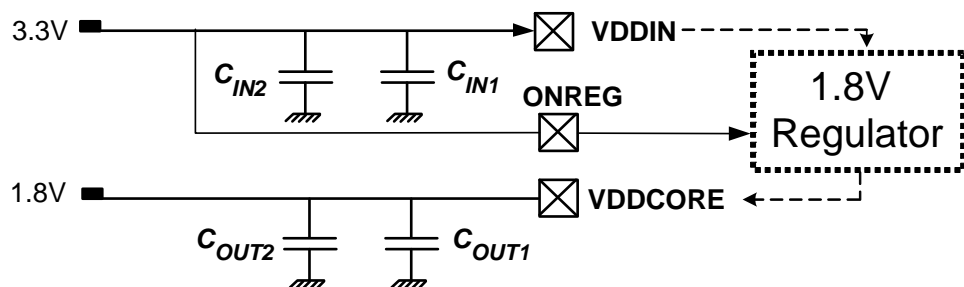

ONREG input must be tied to VDDIN.

5. Power Considerations

5.1 Power Supplies

The AT32UC3A3 has several types of power supply pins:

- **VDDIO:** Powers I/O lines. Voltage is 3.3V nominal
- **VDDANA:** Powers the ADC Voltage and provides the ADVREF voltage is 3.3V nominal
- **VDDIN:** Input voltage for the voltage regulator. Voltage is 3.3V nominal
- **VDDCORE:** Output voltage from regulator for filtering purpose and provides the supply to the core, memories, and peripherals. Voltage is 1.8V nominal

The ground pins GNDCORE are common to VDDCORE and VDDIN. The ground pin for VDDANA is GNDANA. The ground pin for VDDIO is GNDIO

Refer to Electrical Characteristics chapter for power consumption on the various supply pins.

5.2 Voltage Regulator

The AT32UC3A3 embeds a voltage regulator that converts from 3.3V to 1.8V with a load of up to 100 mA. The regulator takes its input voltage from VDDIN, and supplies the output voltage on VDDCORE and powers the core, memories and peripherals.

Adequate output supply decoupling is mandatory for VDDCORE to reduce ripple and avoid oscillations.

The best way to achieve this is to use two capacitors in parallel between VDDCORE and GNDCORE:

- One external 470pF (or 1nF) NPO capacitor (COUT1) should be connected as close to the chip as possible.
- One external 2.2μF (or 3.3μF) X7R capacitor (COUT2).

Adequate input supply decoupling is mandatory for VDDIN in order to improve startup stability and reduce source voltage drop.

The input decoupling capacitor should be placed close to the chip, e.g., two capacitors can be used in parallel (100nF NPO and 4.7μF X7R).

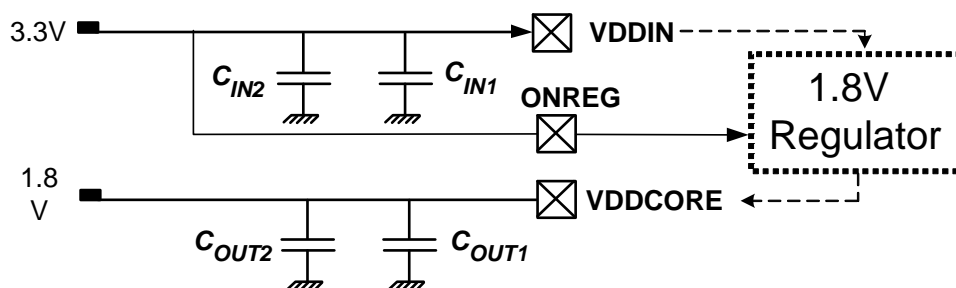

ONREG input must be tied to VDDIN.

6. I/O Line Considerations

6.1 JTAG Pins

TMS and TDI pins have pull-up resistors. TDO pin is an output, driven at up to VDDIO, and has no pull-up resistor.

6.2 RESET_N Pin

The RESET_N pin is a schmitt input and integrates a permanent pull-up resistor to VDDIO. As the product integrates a power-on reset cell, the RESET_N pin can be left unconnected in case no reset from the system needs to be applied to the product.

6.3 TWI Pins

When these pins are used for TWI, the pins are open-drain outputs with slew-rate limitation and inputs with inputs with spike filtering. When used as GPIO pins or used for other peripherals, the pins have the same characteristics as other GPIO pins.

6.4 GPIO Pins

All the I/O lines integrate a programmable pull-up resistor. Programming of this pull-up resistor is performed independently for each I/O line through the I/O Controller. After reset, I/O lines default as inputs with pull-up resistors disabled, except when indicated otherwise in the column “Reset State” of the I/O Controller multiplexing tables.

7. Memories

7.1 Embedded Memories

- Internal High-Speed Flash
 - 256KBytes (AT32UC3A3256/S)
 - 128Kbytes (AT32UC3A3128/S)
 - 64 Kbytes (AT32UC3A364/S)
 - 0 wait state access at up to 36MHz in worst case conditions
 - 1 wait state access at up to 66MHz in worst case conditions
 - Pipelined Flash architecture, allowing burst reads from sequential Flash locations, hiding penalty of 1 wait state access
 - Pipelined Flash architecture typically reduces the cycle penalty of 1 wait state operation to only 15% compared to 0 wait state operation
 - 100 000 write cycles, 15-year data retention capability
 - Sector lock capabilities, Bootloader protection, Security Bit
 - 32 fuses, preserved during Chip Erase
 - User page for data to be preserved during Chip Erase
- Internal High-Speed SRAM
 - 64KBytes, Single-cycle access at full speed on CPU Local Bus and accessible through the High Speed Bud (HSB) matrix
 - 2x32KBytes, accessible independently through the High Speed Bud (HSB) matrix

7.2 Physical Memory Map

The System Bus is implemented as a bus matrix. All system bus addresses are fixed, and they are never remapped in any way, not even in boot.

Note that AVR32UC CPU uses unsegmented translation, as described in the AVR32 Architecture Manual.

The 32-bit physical address space is mapped as follows:

Table 7-1. AT32UC3A3 Physical Memory Map

Device	Start Address	Size	Size	Size
		AT32UC3A3256	AT32UC3A3128	AT32UC3A364
Embedded CPU SRAM	0x00000000	64KByte	64KByte	64KByte
Embedded Flash	0x80000000	256KByte	128KByte	64KByte
EBI SRAM CS0	0xC0000000	16MByte	16MByte	16MByte
EBI SRAM CS2	0xC8000000	16MByte	16MByte	16MByte
EBI SRAM CS3	0xCC000000	16MByte	16MByte	16MByte
EBI SRAM CS4	0xD8000000	16MByte	16MByte	16MByte
EBI SRAM CS5	0xDC000000	16MByte	16MByte	16MByte
EBI SRAM CS1 /SDRAM CS0	0xD0000000	128MByte	128MByte	128MByte
USB Data	0xE0000000	64KByte	64KByte	64KByte
Embedded System SRAM 0	0xFF000000	32KByte	32KByte	32KByte

Table 7-1. AT32UC3A3 Physical Memory Map

Device	Start Address	Size	Size	Size
		AT32UC3A3256	AT32UC3A3128	AT32UC3A364
Embedded System SRAM 1	0xFF008000	32KByte	32KByte	32KByte
HSB-PB Bridge A	0xFFFF0000	64KByte	64KByte	64KByte
HSB-PB Bridge B	0xFFFE0000	64KByte	64KByte	64KByte

7.3 Peripheral Address Map

Table 7-2. Peripheral Address Mapping

Address	Peripheral Name	Bus
0xFF100000	DMACA DMA Controller - DMACA	
0xFF200000	RESERVED	
0xFFFD0000	AES Advanced Encryption Standard - AES	
0xFFFE0000	USB USB 2.0 OTG Interface - USB	
0xFFFE1000	HMATRIX HSB Matrix - HMATRIX	
0xFFFE1400	FLASHC Flash Controller - FLASHC	
0xFFFE1C00	SMC Static Memory Controller - SMC	
0xFFFE2000	SDRAMC SDRAM Controller - SDRAMC	
0xFFFE2400	ECCHRS Error code corrector Hamming and Reed Solomon - ECCHRS	
0xFFFE2800	BUSMON Bus Monitor module - BUSMON	
0xFFFE4000	MCI Multimedia Card Interface - MCI	
0xFFFE8000	MSI Memory Stick Interface - MSI	
0xFFFF0000	PDMA Peripheral DMA Controller - PDMA	
0xFFFF0800	INTC Interrupt controller - INTC	

Table 7-2. Peripheral Address Mapping

0xFFFF0C00	PM	Power Manager - PM
0xFFFF0D00	RTC	Real Time Counter - RTC
0xFFFF0D30	WDT	Watchdog Timer - WDT
0xFFFF0D80	EIC	External Interrupt Controller - EIC
0xFFFF1000	GPIO	General Purpose Input/Output Controller - GPIO
0xFFFF1400	USART0	Universal Synchronous/Asynchronous Receiver/Transmitter - USART0
0xFFFF1800	USART1	Universal Synchronous/Asynchronous Receiver/Transmitter - USART1
0xFFFF1C00	USART2	Universal Synchronous/Asynchronous Receiver/Transmitter - USART2
0xFFFF2000	USART3	Universal Synchronous/Asynchronous Receiver/Transmitter - USART3
0xFFFF2400	SPI0	Serial Peripheral Interface - SPI0
0xFFFF2800	SPI1	Serial Peripheral Interface - SPI1
0xFFFF2C00	TWIM0	Two-wire Master Interface - TWIM0
0xFFFF3000	TWIM1	Two-wire Master Interface - TWIM1
0xFFFF3400	SSC	Synchronous Serial Controller - SSC
0xFFFF3800	TC0	Timer/Counter - TC0
0xFFFF3C00	ADC	Analog to Digital Converter - ADC
0xFFFF4000	DAC	Audio Bitstream DAC - DAC
0xFFFF4400	TC1	Timer/Counter - TC1
0xFFFF4800	RESERVED	

Table 7-2. Peripheral Address Mapping

0xFFFF4c00	RESERVED	
0xFFFF5000	TWIS0	Two-wire Slave Interface - TWIS0
0xFFFF5400	TWIS1	Two-wire Slave Interface - TWIS1

7.4 CPU Local Bus Mapping

Some of the registers in the GPIO module are mapped onto the CPU local bus, in addition to being mapped on the Peripheral Bus. These registers can therefore be reached both by accesses on the Peripheral Bus, and by accesses on the local bus.

Mapping these registers on the local bus allows cycle-deterministic toggling of GPIO pins since the CPU and GPIO are the only modules connected to this bus. Also, since the local bus runs at CPU speed, one write or read operation can be performed per clock cycle to the local bus-mapped GPIO registers.

The following GPIO registers are mapped on the local bus:

Table 7-3. Local Bus Mapped GPIO Registers

Port	Register	Mode	Local Bus Address	Access
A	Output Driver Enable Register (ODER)	WRITE	0x40000040	Write-only
		SET	0x40000044	Write-only
		CLEAR	0x40000048	Write-only
		TOGGLE	0x4000004C	Write-only
	Output Value Register (OVR)	WRITE	0x40000050	Write-only
		SET	0x40000054	Write-only
		CLEAR	0x40000058	Write-only
		TOGGLE	0x4000005C	Write-only
Pin Value Register (PVR)	-	0x40000060	Read-only	
B	Output Driver Enable Register (ODER)	WRITE	0x40000240	Write-only
		SET	0x40000244	Write-only
		CLEAR	0x40000248	Write-only
		TOGGLE	0x4000024C	Write-only
	Output Value Register (OVR)	WRITE	0x40000250	Write-only
		SET	0x40000254	Write-only
		CLEAR	0x40000258	Write-only
		TOGGLE	0x4000025C	Write-only
	Pin Value Register (PVR)	-	0x40000260	Read-only

8. Peripherals

8.1 Clock Connections

8.1.1 Timer/Counters

Each Timer/Counter channel can independently select an internal or external clock source for its counter:

Table 8-1. Timer/Counter clock connections

Source	Name	Connection
Internal	TIMER_CLOCK1	32 KHz clock
	TIMER_CLOCK2	PBA Clock / 2
	TIMER_CLOCK3	PBA Clock / 8
	TIMER_CLOCK4	PBA Clock / 32
	TIMER_CLOCK5	PBA Clock / 128
External	XC0	See Table 8.2 on page 29
	XC1	
	XC2	

8.2 Peripheral Multiplexing on I/O lines

Each GPIO line can be assigned to one of 4 peripheral functions; A, B, C or D. The following table define how the I/O lines on the peripherals A, B, C or D are multiplexed by the GPIO.

Table 8-2. GPIO Controller Function Multiplexing

BGA144	QFP144	PIN	GPIO Pin	Function A	Function B	Function C	Function D
G11	122	PA00	GPIO 0	USART0 - RTS	TC0 - CLK1	SPI1 - NPCS[3]	
G12	123	PA01	GPIO 1	USART0 - CTS	TC0 - A1	USART2 - RTS	
D8	15	PA02	GPIO 2	USART0 - CLK	TC0 - B1	SPI0 - NPCS[0]	
G10	125	PA03	GPIO 3	USART0 - RXD	EIC - EXTINT[4]	DAC - DATA[0]	
F9	126	PA04	GPIO 4	USART0 - TXD	EIC - EXTINT[5]	DAC - DATAN[0]	
F10	124	PA05	GPIO 5	USART1 - RXD	TC1 - CLK0	USB - USB_ID	
F8	127	PA06	GPIO 6	USART1 - TXD	TC1 - CLK1	USB - USB_VBOF	
E10	133	PA07	GPIO 7	SPI0 - NPCS[3]	DAC - DATAN[0]	USART1 - CLK	
C11	137	PA08	GPIO 8	SPI0 - SCK	DAC - DATA[0]	TC1 - B1	
B12	139	PA09	GPIO 9	SPI0 - NPCS[0]	EIC - EXTINT[6]	TC1 - A1	
C12	138	PA10	GPIO 10	SPI0 - MOSI	USB - USB_VBOF	TC1 - B0	
D10	136	PA11	GPIO 11	SPI0 - MISO	USB - USB_ID	TC1 - A2	
E12	132	PA12	GPIO 12	USART1 - CTS	SPI0 - NPCS[2]	TC1 - A0	
F11	129	PA13	GPIO 13	USART1 - RTS	SPI0 - NPCS[1]	EIC - EXTINT[7]	

Table 8-2. GPIO Controller Function Multiplexing

J6	100	PA14	GPIO 14	SPI0 - NPCS[1]	TWIMS0 - TWALM	TWIMS1 - TWCK	
J7	101	PA15	GPIO 15	MCI - CMD[1]	SPI1 - SCK	TWIMS1 - TWD	
F12	128	PA16	GPIO 16	MCI - DATA[11]	SPI1 - MOSI	TC1 - CLK2	
H7	116	PA17	GPIO 17	MCI - DATA[10]	SPI1 - NPCS[1]	ADC - AD[7]	
K8	115	PA18	GPIO 18	MCI - DATA[9]	SPI1 - NPCS[2]	ADC - AD[6]	
J8	114	PA19	GPIO 19	MCI - DATA[8]	SPI1 - MISO	ADC - AD[5]	
J9	113	PA20	GPIO 20	NMI	SSC - RX_FRAME_SYNC	ADC - AD[4]	
H9	109	PA21	GPIO 21	ADC - AD[0]	EIC - EXTINT[0]	USB - USB_ID	
H10	110	PA22	GPIO 22	ADC - AD[1]	EIC - EXTINT[1]	USB - USB_VBOF	
G8	111	PA23	GPIO 23	ADC - AD[2]	EIC - EXTINT[2]	DAC - DATA[1]	
G9	112	PA24	GPIO 24	ADC - AD[3]	EIC - EXTINT[3]	DAC - DATAN[1]	
E9	119	PA25	GPIO 25	TWIMS0 - TWD	TWIMS1 - TWALM	USART1 - DCD	
D9	120	PA26	GPIO 26	TWIMS0 - TWCK	USART2 - CTS	USART1 - DSR	
A4	26	PA27	GPIO 27	MCI - CLK	SSC - RX_DATA	USART3 - RTS	MSI - SCLK
A3	28	PA28	GPIO 28	MCI - CMD[0]	SSC - RX_CLOCK	USART3 - CTS	MSI - BS
A6	23	PA29	GPIO 29	MCI - DATA[0]	USART3 - TXD	TC0 - CLK0	MSI - DATA[0]
C7	14	PA30	GPIO 30	MCI - DATA[1]	USART3 - CLK	DMACA - DMAACK[0]	MSI - DATA[1]
B3	29	PA31	GPIO 31	MCI - DATA[2]	USART2 - RXD	DMACA - DMARQ[0]	MSI - DATA[2]
A2	30	PB00	GPIO 32	MCI - DATA[3]	USART2 - TXD	ADC - TRIGGER	MSI - DATA[3]
C4	27	PB01	GPIO 33	MCI - DATA[4]	DAC - DATA[1]	EIC - SCAN[0]	MSI - INS
B4	25	PB02	GPIO 34	MCI - DATA[5]	DAC - DATAN[1]	EIC - SCAN[1]	
A5	24	PB03	GPIO 35	MCI - DATA[6]	USART2 - CLK	EIC - SCAN[2]	
B6	22	PB04	GPIO 36	MCI - DATA[7]	USART3 - RXD	EIC - SCAN[3]	
H12	121	PB05	GPIO 37	USB - USB_ID	TC0 - A0	EIC - SCAN[4]	
D12	134	PB06	GPIO 38	USB - USB_VBOF	TC0 - B0	EIC - SCAN[5]	
D11	135	PB07	GPIO 39	SPI1 - SCK	SSC - TX_CLOCK	EIC - SCAN[6]	
C8	11	PB08	GPIO 40	SPI1 - MISO	SSC - TX_DATA	EIC - SCAN[7]	
E7	17	PB09	GPIO 41	SPI1 - NPCS[0]	SSC - RX_DATA	EBI - NCS[4]	
D7	16	PB10	GPIO 42	SPI1 - MOSI	SSC - RX_FRAME_SYNC	EBI - NCS[5]	
B2	31	PB11	GPIO 43	USART1 - RXD	SSC - TX_FRAME_SYNC	PM - GCLK[1]	
K5	98	PC00	GPIO 45				

Table 8-2. GPIO Controller Function Multiplexing

H6	99	PC01	GPIO 46				
A7	18	PC02	GPIO 47				
B7	19	PC03	GPIO 48				
A8	13	PC04	GPIO 49				
A9	12	PC05	GPIO 50				
G1	55	PX00	GPIO 51	EBI - DATA[10]	USART0 - RXD	USART1 - RI	
H1	59	PX01	GPIO 52	EBI - DATA[9]	USART0 - TXD	USART1 - DTR	
J2	62	PX02	GPIO 53	EBI - DATA[8]	USART0 - CTS	PM - GCLK[0]	
K1	63	PX03	GPIO 54	EBI - DATA[7]	USART0 - RTS		
J1	60	PX04	GPIO 55	EBI - DATA[6]	USART1 - RXD		
G2	58	PX05	GPIO 56	EBI - DATA[5]	USART1 - TXD		
F3	53	PX06	GPIO 57	EBI - DATA[4]	USART1 - CTS		
F2	54	PX07	GPIO 58	EBI - DATA[3]	USART1 - RTS		
D1	50	PX08	GPIO 59	EBI - DATA[2]	USART3 - RXD		
C1	49	PX09	GPIO 60	EBI - DATA[1]	USART3 - TXD		
B1	37	PX10	GPIO 61	EBI - DATA[0]	USART2 - RXD		
L1	67	PX11	GPIO 62	EBI - NWE1	USART2 - TXD		
D6	34	PX12	GPIO 63	EBI - NWE0	USART2 - CTS		
C6	33	PX13	GPIO 64	EBI - NRD	USART2 - RTS		
M4	68	PX14	GPIO 65	EBI - NCS[1]		TC0 - A0	
E6	40	PX15	GPIO 66	EBI - ADDR[19]	USART3 - RTS	TC0 - B0	
C5	32	PX16	GPIO 67	EBI - ADDR[18]	USART3 - CTS	TC0 - A1	
K6	83	PX17	GPIO 68	EBI - ADDR[17]	DMACA - DMARQ[1]	TC0 - B1	
L6	84	PX18	GPIO 69	EBI - ADDR[16]	DMACA - DMAACK[1]	TC0 - A2	
D5	35	PX19	GPIO 70	EBI - ADDR[15]	EIC - SCAN[0]	TC0 - B2	
L4	73	PX20	GPIO 71	EBI - ADDR[14]	EIC - SCAN[1]	TC0 - CLK0	
M5	80	PX21	GPIO 72	EBI - ADDR[13]	EIC - SCAN[2]	TC0 - CLK1	
M1	72	PX22	GPIO 73	EBI - ADDR[12]	EIC - SCAN[3]	TC0 - CLK2	
M6	85	PX23	GPIO 74	EBI - ADDR[11]	EIC - SCAN[4]	SSC - TX_CLOCK	
M7	86	PX24	GPIO 75	EBI - ADDR[10]	EIC - SCAN[5]	SSC - TX_DATA	
M8	92	PX25	GPIO 76	EBI - ADDR[9]	EIC - SCAN[6]	SSC - RX_DATA	
L9	90	PX26	GPIO 77	EBI - ADDR[8]	EIC - SCAN[7]	SSC - RX_FRAME_SYN C	
K9	89	PX27	GPIO 78	EBI - ADDR[7]	SPI0 - MISO	SSC - TX_FRAME_SYN C	
L10	91	PX28	GPIO 79	EBI - ADDR[6]	SPI0 - MOSI	SSC - RX_CLOCK	

Table 8-2. GPIO Controller Function Multiplexing

K11	94	PX29	GPIO 80	EBI - ADDR[5]	SPI0 - SCK		
M11	96	PX30	GPIO 81	EBI - ADDR[4]	SPI0 - NPCS[0]		
M10	97	PX31	GPIO 82	EBI - ADDR[3]	SPI0 - NPCS[1]		
M9	93	PX32	GPIO 83	EBI - ADDR[2]	SPI0 - NPCS[2]		
M12	95	PX33	GPIO 84	EBI - ADDR[1]	SPI0 - NPCS[3]		
J3	61	PX34	GPIO 85	EBI - ADDR[0]	SPI1 - MISO	PM - GCLK[0]	
C2	38	PX35	GPIO 86	EBI - DATA[15]	SPI1 - MOSI	PM - GCLK[1]	
D3	44	PX36	GPIO 87	EBI - DATA[14]	SPI1 - SCK	PM - GCLK[2]	
D2	45	PX37	GPIO 88	EBI - DATA[13]	SPI1 - NPCS[0]	PM - GCLK[3]	
E1	51	PX38	GPIO 89	EBI - DATA[12]	SPI1 - NPCS[1]	USART1 - DCD	
F1	52	PX39	GPIO 90	EBI - DATA[11]	SPI1 - NPCS[2]	USART1 - DSR	
A1	36	PX40	GPIO 91	EBI - SDCS			
M2	71	PX41	GPIO 92	EBI - CAS			
M3	69	PX42	GPIO 93	EBI - RAS			
L7	88	PX43	GPIO 94	EBI - SDA10	USART1 - RI		
K2	66	PX44	GPIO 95	EBI - SDWE	USART1 - DTR		
L3	70	PX45	GPIO 96	EBI - SDCK			
K4	74	PX46	GPIO 97	EBI - SDCKE			
D4	39	PX47	GPIO 98	EBI - NANDOE	ADC - TRIGGER	MCI - DATA[11]	
F5	41	PX48	GPIO 99	EBI - ADDR[23]	USB - USB_VBOF	MCI - DATA[10]	
F4	43	PX49	GPIO 100	EBI - CFRNW	USB - USB_ID	MCI - DATA[9]	
G4	75	PX50	GPIO 101	EBI - CFCE2	TC1 - B2	MCI - DATA[8]	
G5	77	PX51	GPIO 102	EBI - CFCE1	DMACA - DMAACK[0]	MCI - DATA[15]	
K7	87	PX52	GPIO 103	EBI - NCS[3]	DMACA - DMARQ[0]	MCI - DATA[14]	
E4	42	PX53	GPIO 104	EBI - NCS[2]		MCI - DATA[13]	
E3	46	PX54	GPIO 105	EBI - NWAIT	USART3 - TXD	MCI - DATA[12]	
J5	79	PX55	GPIO 106	EBI - ADDR[22]	EIC - SCAN[3]	USART2 - RXD	
J4	78	PX56	GPIO 107	EBI - ADDR[21]	EIC - SCAN[2]	USART2 - TXD	
H4	76	PX57	GPIO 108	EBI - ADDR[20]	EIC - SCAN[1]	USART3 - RXD	
H3	57	PX58	GPIO 109	EBI - NCS[0]	EIC - SCAN[0]	USART3 - TXD	
G3	56	PX59	GPIO 110	EBI - NANDWE		MCI - CMD[1]	

8.3 Oscillator Pinout

Table 8-3. Oscillator Pinout

pin	pin	Pad	Oscillator pin
A7	18	PC02	xin0
A8	13	PC04	xin1

Table 8-3. Oscillator Pinout

K5	98	PC00	xin32
B7	19	PC03	xout0
A9	12	PC05	xout1
H6	99	PC01	xout32

8.4 Peripheral overview

8.4.1 Power Manager

- Controls integrated oscillators and PLLs
- Generates clocks and resets for digital logic
- Supports 2 crystal oscillators 4MHz-16MHz
- Supports 2 PLLs 48-150MHz
- Supports 32KHz ultra-low power oscillator
- Integrated low-power RC oscillator
- On-the fly frequency change of CPU, HSB, PBA, and PBB clocks
- Sleep modes allow simple disabling of logic clocks, PLLs, and oscillators
- Module-level clock gating through maskable peripheral clocks
- Wake-up from internal or external interrupts
- Generic clocks with wide frequency range provided
- Automatic identification of reset sources
- Controls brownout detector (BOD), RC oscillator, and bandgap voltage reference through control and calibration registers

8.4.2 Real Time Counter

- 32-bit real-time counter with 16-bit prescaler
- Clocked from RC oscillator or 32KHz oscillator
- Long delays
 - Max timeout 272years
- High resolution: Max count frequency 16KHz
- Extremely low power consumption
- Available in all sleep modes except Static
- Interrupt on wrap

8.4.3 Watchdog Timer

- Watchdog timer counter with 32-bit prescaler
- Clocked from the system RC oscillator (RCSYS)

8.4.4 Interrupt Controller

- Autovector low latency interrupt service with programmable priority
 - 4 priority levels for regular, maskable interrupts
 - One Non-Maskable Interrupt

- Up to 64 groups of interrupts with up to 32 interrupt requests in each

8.4.5 External Interrupts Controller

- Dedicated interrupt request for each interrupt
- Individually maskable interrupts
- Interrupt on rising or falling edge
- Interrupt on high or low level
- Asynchronous interrupts for sleep modes without clock
- Filtering of interrupt lines
- Maskable NMI interrupt
- Keypad scan support
-

8.4.6 Flash Controller

- Controls flash block with dual read ports allowing staggered reads.
- Supports 0 and 1 wait state bus access.
- Allows interleaved burst reads for systems with one wait state, outputting one 32-bit word per clock cycle.
- 32-bit HSB interface for reads from flash array and writes to page buffer.
- 32-bit PB interface for issuing commands to and configuration of the controller.
- 16 lock bits, each protecting a region consisting of (total number of pages in the flash block / 16) pages.
- Regions can be individually protected or unprotected.
- Additional protection of the Boot Loader pages.
- Supports reads and writes of general-purpose NVM bits.
- Supports reads and writes of additional NVM pages.
- Supports device protection through a security bit.
- Dedicated command for chip-erase, first erasing all on-chip volatile memories before erasing flash and clearing security bit.
- Interface to Power Manager for power-down of flash-blocks in sleep mode.

8.4.7 HSB Bus Matrix

- User Interface on peripheral bus
- Configurable Number of Masters (Up to sixteen)
- Configurable Number of Slaves (Up to sixteen)
- One Decoder for Each Master
- Three Different Memory Mappings for Each Master (Internal and External boot, Remap)
- One Remap Function for Each Master
- Programmable Arbitration for Each Slave
 - Round-Robin
 - Fixed Priority
- Programmable Default Master for Each Slave
 - No Default Master
 - Last Accessed Default Master
 - Fixed Default Master

- One Cycle Latency for the First Access of a Burst
- Zero Cycle Latency for Default Master
- One Special Function Register for Each Slave (Not dedicated)

8.4.8 External Bus Interface

- Optimized for application memory space support
- Integrates three external memory controllers:
 - Static Memory Controller (SMC)
 - SDRAM Controller (SDRAMC)
 - Error Corrected Code (ECC) controller
- Additional logic for NAND Flash/SmartMedia™ and CompactFlash™ support
 - NAND Flash support: 8-bit as well as 16-bit devices are supported
 - CompactFlash support: all modes (Attribute Memory, Common Memory, I/O, True IDE) are supported but the signals _IOIS16 (I/O and True IDE modes) and _ATA SEL (True IDE mode) are not handled.
- Optimized external bus:16-bit data bus
 - Up to 24-bit Address Bus, Up to 8-Mbytes Addressable
 - Optimized pin multiplexing to reduce latencies on external memories
- Up to 6 Chip Selects, Configurable Assignment:
 - Static Memory Controller on Chip Select 0
 - SDRAM Controller or Static Memory Controller on Chip Select 1
 - Static Memory Controller on Chip Select 2, Optional NAND Flash support
 - Static Memory Controller on Chip Select 3, Optional NAND Flash support
 - Static Memory Controller on Chip Select 4, Optional CompactFlash™ support
 - Static Memory Controller on Chip Select 5, Optional CompactFlash™ support

8.4.9 Static Memory Controller

- 6 chip selects available
- 64-Mbytes address space per chip select
- 8- or 16-bit data bus
- Word, halfword, byte transfers
- Byte write or byte select lines
- Programmable setup, pulse and hold time for read signals per chip select
- Programmable setup, pulse and hold time for write signals per chip select
- Programmable data float time per chip select
- Compliant with LCD module
- External wait request
- Automatic switch to slow clock mode
- Asynchronous read in page mode supported: page size ranges from 4 to 32 bytes

8.4.10 SDRAM Controller

- 128-Mbytes address space
- Numerous configurations supported
 - 2K, 4K, 8K row address memory parts
 - SDRAM with two or four internal banks
 - SDRAM with 16-bit data path
- Programming facilities
 - Word, halfword, byte access
 - Automatic page break when memory boundary has been reached
 - Multibank ping-pong access

- Timing parameters specified by software
- Automatic refresh operation, refresh rate is programmable
- Automatic update of DS, TCR and PASR parameters (mobile SDRAM devices)
- Energy-saving capabilities
 - Self-refresh, power-down, and deep power-down modes supported
 - Supports mobile SDRAM devices
- Error detection
 - Refresh error interrupt
- SDRAM power-up initialization by software
- CAS latency of one, two, and three supported
- Auto Precharge command not used

8.4.11 Peripheral DMA Controller

- 8 channels
- Generates transfers to/from peripherals such as USART, SSC and SPI
- Two address pointers/counters per channel allowing double buffering
- Performance monitors to measure average and maximum transfer latency

8.4.12 DMA Controller

- 2 HSB Master Interfaces
- 4 Channels
- Software and Hardware Handshaking Interfaces
 - 9 Hardware Handshaking Interfaces
- Memory/Non-Memory Peripherals to Memory/Non-Memory Peripherals Transfer
- Single-block DMA Transfer
- Multi-block DMA Transfer
 - Linked Lists
 - Auto-Reloading
 - Contiguous Blocks
- DMA Controller is Always the Flow Controller
- Additional Features
 - Scatter and Gather Operations
 - Channel Locking
 - Bus Locking
 - FIFO Mode
 - Pseudo Fly-by Operation

8.4.13 General-Purpose Input/Output Controller

Each I/O line of the GPIO features:

- Configurable pin-change, rising-edge or falling-edge interrupt on any I/O line
- A glitch filter providing rejection of pulses shorter than one clock cycle
- Input visibility and output control
- Multiplexing of up to four peripheral functions per I/O line
- Programmable internal pull-up resistor

Serial Peripheral Interface

- Compatible with an embedded 32-bit microcontroller
- Supports communication with serial external devices
 - Four chip selects with external decoder support allow communication with up to 15 peripherals

- Serial memories, such as DataFlash and 3-wire EEPROMs
- Serial peripherals, such as ADCs, DACs, LCD controllers, CAN controllers and Sensors
- External co-processors
- Master or Slave Serial Peripheral Bus Interface
 - 4 - to 16-bit programmable data length per chip select
 - Programmable phase and polarity per chip select
 - Programmable transfer delays between consecutive transfers and between clock and data per chip select
 - Programmable delay between consecutive transfers
 - Selectable mode fault detection
- Connection to Peripheral DMA Controller channel capabilities optimizes data transfers
 - One channel for the receiver, one channel for the transmitter
 - Next buffer support
 - Four character FIFO in reception

8.4.14 Two-Wire Slave Interface

- Compatible with I²C standard
 - 100 and 400 kbit/s transfer speeds
 - 7 and 10-bit and General Call addressing
- Compatible with SMBus standard
 - Hardware Packet Error Checking (CRC) generation and verification with ACK response
 - SMBALERT interface
 - 25 ms clock low timeout delay
 - 25 ms slave cumulative clock low extend time
- Compatible with PMBus
- DMA interface for reducing CPU load
- Arbitrary transfer lengths, including 0 data bytes
- Optional clock stretching if transmit or receive buffers not ready for data transfer
- 32-bit Peripheral Bus interface for configuration of the interface

8.4.15 Two-Wire Master Interface

- Compatible with I²C standard
 - Multi-master support
 - 100 and 400 kbit/s transfer speeds
 - 7- and 10-bit and General Call addressing
- Compatible with SMBus standard
 - Hardware Packet Error Checking (CRC) generation and verification with ACK control
 - SMBus ALERT interface
 - 25 ms clock low timeout delay
 - 10 ms master cumulative clock low extend time
 - 25 ms slave cumulative clock low extend time

- Compatible with PMBus
- Compatible with Atmel Two-Wire Interface Serial Memories
- DMA interface for reducing CPU load
- Arbitrary transfer lengths, including 0 data bytes
- Optional clock stretching if transmit or receive buffers not ready for data transfer

8.4.16 Synchronous Serial Controller

- Provides serial synchronous communication links used in audio and telecom applications
- Independent receiver and transmitter, common clock divider
- Interfaced with two Peripheral DMA Controller channels to reduce processor overhead
- Configurable frame sync and data length
- Receiver and transmitter can be configured to start automatically or on detection of different events on the frame sync signal
- Receiver and transmitter include a data signal, a clock signal and a frame synchronization signal

8.4.17 Universal Synchronous Asynchronous Receiver Transmitter

- Programmable Baud Rate Generator
- 5- to 9-bit Full-duplex Synchronous or Asynchronous Serial Communications
 - 1, 1.5 or 2 Stop Bits in Asynchronous Mode or 1 or 2 Stop Bits in Synchronous Mode
 - Parity Generation and Error Detection
 - Framing Error Detection, Overrun Error Detection
 - MSB- or LSB-first
 - Optional Break Generation and Detection
 - By 8 or by 16 Over-sampling Receiver Frequency
 - Optional Hardware Handshaking RTS-CTS
 - Optional Modem Signal Management DTR-DSR-DCD-RI
 - Receiver Time-out and Transmitter Timeguard
 - Optional Multidrop Mode with Address Generation and Detection
- RS485 with Driver Control Signal
- ISO7816, T = 0 or T = 1 Protocols for Interfacing with Smart Cards
 - NACK Handling, Error Counter with Repetition and Iteration Limit
- IrDA Modulation and Demodulation
 - Communication at up to 115.2 Kbps
- SPI Mode
 - Master or Slave
 - Serial Clock Programmable Phase and Polarity
 - SPI Serial Clock (CLK) Frequency up to Internal Clock Frequency CLK_USART/4
- LIN Mode
 - Compliant with LIN 1.3 and LIN 2.0 specifications
 - Master or Slave
 - Processing of frames with up to 256 data bytes
 - Response Data length can be configurable or defined automatically by the Identifier
 - Self synchronization in Slave node configuration
 - Automatic processing and verification of the “Synch Break” and the “Synch Field”
 - The “Synch Break” is detected even if it is partially superimposed with a data byte
 - Automatic Identifier parity calculation/sending and verification
 - Parity sending and verification can be disabled
 - Automatic Checksum calculation/sending and verification
 - Checksum sending and verification can be disabled
 - Support both “Classic” and “Enhanced” checksum types

- Full LIN error checking and reporting
- Frame Slot Mode: the Master allocates slots to the scheduled frames automatically.
- Generation of the Wakeup signal
- Test Modes
 - Remote Loopback, Local Loopback, Automatic Echo
- Supports Connection of Two Peripheral DMA Controller Channels (PDCA)
 - Offers Buffer Transfer without Processor Intervention

8.4.18 USB On-The-Go Interface

- Compatible with the USB 2.0 specification
- Supports High (480Mbps), Full (12Mbps) and Low (1.5Mbps) speed communication and On-The-Go
- nine pipes/endpoints
- 2368 of Embedded Dual-Port RAM (DPRAM) for Pipes/Endpoints
- Up to 2 memory banks per Pipe/Endpoint (Not for Control Pipe/Endpoint)
- Flexible Pipe/Endpoint configuration and management with dedicated DMA channels
- On-Chip UTMI transceiver including Pull-Ups/Pull-downs
- On-Chip OTG pad including VBUS analog comparator

8.4.19 Timer/Counter

- Three 16-bit Timer Counter channels
- A wide range of functions including:
 - Frequency measurement
 - Event counting
 - Interval measurement
 - Pulse generation
 - Delay timing
 - Pulse width modulation
 - Up/down capabilities
- Each channel is user-configurable and contains:
 - Three external clock inputs
 - Five internal clock inputs
 - Two multi-purpose input/output signals
- Internal interrupt signal
- Two global registers that act on all three TC channels

8.4.20 Analog-to-Digital Converter

- Integrated multiplexer offering up to eight independent analog inputs
- Individual enable and disable of each channel
- Hardware or software trigger
 - External trigger pin
 - Timer counter outputs (corresponding TIOA trigger)
- PDC support
- Possibility of ADC timings configuration
- Sleep mode and conversion sequencer
 - Automatic wakeup on trigger and back to sleep mode after conversions of all enabled channels

8.4.21 HSB Bus Performance Monitor

- Allows performance monitoring of High Speed Bus master interfaces
 - Up to 4 masters can be monitored
 - Peripheral Bus access to monitor registers
- The following is monitored
 - Data transfer cycles
 - Bus stall cycles
 - Maximum access latency for a single transfer
- Automatic handling of event overflow

8.4.22 Multimedia Card Interface

- Compatible with Multimedia Card specification version 4.2
- Compatible with SD Memory Card specification version 2.0
- Compatible with SDIO specification version 1.1
- Compatible with CE-ATA specification 1.1
- Cards clock rate up to master clock divided by two
- High Speed mode support
- Embedded power management to slow down clock rate when not used
- Supports 2 Slots
 - Each slot for either a MultiMediaCard bus (up to 30 cards) or an SD Memory Card
- Support for stream, block and multi-block data read and write
- Supports connection to DMA Controller
 - Minimizes processor intervention for large buffer transfers
- Built in FIFO (from 16 to 256 bytes) with large memory aperture supporting incremental access
- Support for CE-ATA completion signal disable command
- Protection against unexpected modification on-the-Fly of the configuration registers

8.4.23 Error Corrected Code Controller

- Hardware Error Corrected Code Generation with two methods :
 - Hamming code detection and correction by software (ECC-H)
 - Reed-Solomon code detection by hardware, correction by hardware or software (ECC-RS)
- Supports NAND Flash and SmartMedia™ devices with 8- or 16-bit data path for ECC-H, and with 8-bit data path for ECC-RS
- Supports NAND Flash and SmartMedia™ with page sizes of 512, 1056, 2112, and 4224 bytes (specified by software)
- ECC_H supports :
 - One bit correction per page of 512,1024,2048, or 4096 bytes
 - One bit correction per sector of 512 bytes of data for a page size of 512, 1024, 2048, or 4096 bytes
 - One bit correction per sector of 256 bytes of data for a page size of 512, 1024, 2048, or 4096 bytes
- ECC_RS supports :
 - 4 errors correction per sector of 512 bytes of data for a page size of 512, 1024, 2048, and 4096 bytes with 8-bit data path

8.4.24 Advanced Encryption Standard

- Compliant with *FIPS Publication 197, Advanced Encryption Standard (AES)*
- 128-bit/192-bit/256-bit cryptographic key
- 12/14/16 clock cycles encryption/decryption processing time with a 128-bit/192-bit/256-bit cryptographic key
- Support of the five standard modes of operation specified in the *NIST Special Publication 800-38A, Recommendation for Block Cipher Modes of Operation - Methods and Techniques*:
 - Electronic Code Book (ECB)
 - Cipher Block Chaining (CBC)
 - Cipher Feedback (CFB)
 - Output Feedback (OFB)
 - Counter (CTR)
- 8-, 16-, 32-, 64- and 128-bit data size possible in CFB mode
- Last output data mode allows optimized Message Authentication Code (MAC) generation
- Hardware counter measures against differential power analysis attacks
- Connection to DMA Controller capabilities optimizes data transfers for all operating modes

8.4.25 Audio Bitstream DAC

- Digital Stereo DAC
- Oversampled D/A conversion architecture
 - Oversampling ratio fixed 128x
 - FIR equalization filter
 - Digital interpolation filter: Comb4
 - 3rd Order Sigma-Delta D/A converters
- Digital bitstream outputs
- Parallel interface
- Connected to DMA Controller for background transfer without CPU intervention

8.4.26 On-Chip Debug

- Debug interface in compliance with IEEE-ISTO 5001-2003 (Nexus 2.0) Class 2+
- JTAG access to all on-chip debug functions
- Advanced program, data, ownership, and watchpoint trace supported
- NanoTrace JTAG-based trace access
- Auxiliary port for high-speed trace information
- Hardware support for 6 program and 2 data breakpoints
- Unlimited number of software breakpoints supported
- Automatic CRC check of memory regions

8.4.27 JTAG and Boundary Scan

- IEEE1149.1 compliant JTAG Interface
- Boundary-Scan Chain for board-level testing
- Direct memory access and programming capabilities through JTAG interface
- On-Chip Debug access in compliance with IEEE-ISTO 5001-2003 (Nexus 2.0)
-

9. Boot Sequence

This chapter summarizes the boot sequence of the AT32UC3A3. The behavior after power-up is controlled by the Power Manager. For specific details, refer to [Section 8. "Power Manager \(PM\)" on page 36](#).

9.1 Starting of Clocks

After power-up, the device will be held in a reset state by the Power-On Reset circuitry, until the power has stabilized throughout the device. Once the power has stabilized, the device will use the internal RC Oscillator as clock source.

On system start-up, the PLLs are disabled. All clocks to all modules are running. No clocks have a divided frequency, all parts of the system receives a clock with the same frequency as the internal RC Oscillator.

9.2 Fetching of Initial Instructions

After reset has been released, the AVR32 UC CPU starts fetching instructions from the reset address, which is 0x8000_0000. This address points to the first address in the internal Flash.

The code read from the internal Flash is free to configure the system to use for example the PLLs, to divide the frequency of the clock routed to some of the peripherals, and to gate the clocks to unused peripherals.

10. Electrical Characteristics

10.1 Absolute Maximum Ratings*

Operating Temperature	-40°C to +85°C
Storage Temperature	-60°C to +150°C
Voltage on Input Pin with respect to Ground	-0.3V to 3.6V
Maximum Operating Voltage (VDDCORE)	1.95V
Maximum Operating Voltage (VDDIO).....	3.6V
Total DC Output Current on all I/O Pin for TQFP144 packag	370 mA
for TBGA144 package	370 mA

*NOTICE: Stresses beyond those listed under “Absolute Maximum Ratings” may cause permanent damage to the device. This is a stress rating only and functional operation of the device at these or other conditions beyond those indicated in the operational sections of this specification is not implied. Exposure to absolute maximum rating conditions for extended periods may affect device reliability.

10.2 DC Characteristics

The following characteristics are applicable to the operating temperature range: $T_A = -40^{\circ}\text{C}$ to 85°C , unless otherwise specified and are certified for a junction temperature up to $T_J = 100^{\circ}\text{C}$.

Symbol	Parameter	Condition	Min.	Typ.	Max.	Units
V_{VDDIO}	DC Supply Peripheral I/Os		3.0		3.6	V
V_{IL}	Input Low-level Voltage		-0.3		+0.8	V
V_{IH}	Input High-level Voltage		2.0		$V_{VDDIO} + 0.3$	V
V_{OL}	Output Low-level Voltage	$I_{OL} = -2\text{mA}$ for Pin drive x1 $I_{OL} = -4\text{mA}$ for Pin drive x2 $I_{OL} = -8\text{mA}$ for Pin drive x3			0.4	V
V_{OH}	Output High-level Voltage	$I_{OL} = 2\text{mA}$ for Pin drive x1 $I_{OL} = 4\text{mA}$ for Pin drive x2 $I_{OL} = 8\text{mA}$ for Pin drive x3	$V_{VDDIO} - 0.4$			V
I_{LEAK}	Input Leakage Current	Pullup resistors disabled				μA
C_{IN}	Input Capacitance			7		pF
R_{PULLUP}	Pull-up Resistance		9	15	25	Ohm
I_O	Output Current Pin drive x1 Pin drive x2 Pin drive x3 See Table 10-1				2.0 4.0 8.0	mA
I_{SC}	Static Current	On $V_{VDDIN} = 3.3\text{V}$, CPU in static mode	$T_A = 25^{\circ}\text{C}$		TBD	μA
			$T_A = 85^{\circ}\text{C}$		TBD	μA

Table 10-1. Pins drive capabilities

PIN	Drive	PIN	Drive	PIN	Drive
PA00	x3	PB05	x1	PX24	x2
PA01	x1	PB06	x1	PX25	x2
PA02	x1	PB07	x3	PX26	x2
PA03	x1	PB08	x2	PX27	x2
PA04	x1	PB09	x2	PX28	x2
PA05	x1	PB10	x2	PX29	x2
PA06	x1	PB11	x1	PX30	x2
PA07	x1	PC00	x1	PX31	x2
PA08	x3	PC01	x1	PX32	x2
PA09	x2	PC02	x1	PX33	x2
PA10	x2	PC03	x1	PX34	x2
PA11	x2	PC04	x1	PX35	x2
PA12	x1	PC05	x1	PX36	x2
PA13	x1	PX00	x2	PX37	x2
PA14	x1	PX01	x2	PX38	x2
PA15	x1	PX02	x2	PX39	x2
PA16	x1	PX03	x2	PX40	x2
PA17	x1	PX04	x2	PX41	x2
PA18	x1	PX05	x2	PX42	x2
PA19	x1	PX06	x2	PX43	x2
PA20	x1	PX07	x2	PX44	x2
PA21	x1	PX08	x2	PX45	x3
PA22	x1	PX09	x2	PX46	x2
PA23	x1	PX10	x2	PX47	x2
PA24	x1	PX11	x2	PX48	x2
PA25	x1	PX12	x2	PX49	x2
PA26	x1	PX13	x2	PX50	x2
PA27	x2	PX14	x2	PX51	x2
PA28	x1	PX15	x2	PX52	x2
PA29	x1	PX16	x2	PX53	x2
PA30	x1	PX17	x2	PX54	x2
PA31	x1	PX18	x2	PX55	x2
PB00	x1	PX19	x2	PX56	x2
PB01	x1	PX20	x2	PX57	x2
PB02	x1	PX21	x2	PX58	x2
PB03	x1	PX22	x2	PX59	x2
PB04	x1	PX23	x2		

10.3 Regulator characteristics

10.3.1 Electrical characteristics

Symbol	Parameter	Condition	Min.	Typ.	Max.	Units
V_{VDDIN}	Supply voltage (input)		2.7	3.3	3.6	V
$V_{VDDCORE}$	Supply voltage (output)		1.81	1.85	1.89	V
I_{OUT}	Maximum DC output current with $V_{VDDIN} = 3.3V$				100	mA
	Maximum DC output current with $V_{VDDIN} = 2.7V$				90	mA

10.3.2 Decoupling requirements

Symbol	Parameter	Condition	Typ.	Techno.	Units
C_{IN1}	Input Regulator Capacitor 1		1	NPO	nF
C_{IN2}	Input Regulator Capacitor 2		4.7	X7R	uF
C_{OUT1}	Output Regulator Capacitor 1		470	NPO	pF
C_{OUT2}	Output Regulator Capacitor 2		2.2	X7R	uF

10.3.3 BOD

Table 10-2. BODLEVEL Values

BODLEVEL Value	Typ.	Units.
111111b	1.58	V
101000b	1.62	V
100000b	1.67	V
011000b	1.77	V
000000b	1.92	V

The values in [Table 10-2](#) describes the values of the BODLEVEL in the flash FGPFR1 register.

10.4 Power Consumption

The values in [Table 10-3](#) and [Table 10-4 on page 48](#) are measured values of power consumption with operating conditions as follows:

- $V_{DDIO} = 3.3V$
- $T_A = 25^{\circ}C, T_A = 85^{\circ}C$
- I/Os are configured in input, pull-up enabled.

Figure 10-1. Measurement setup

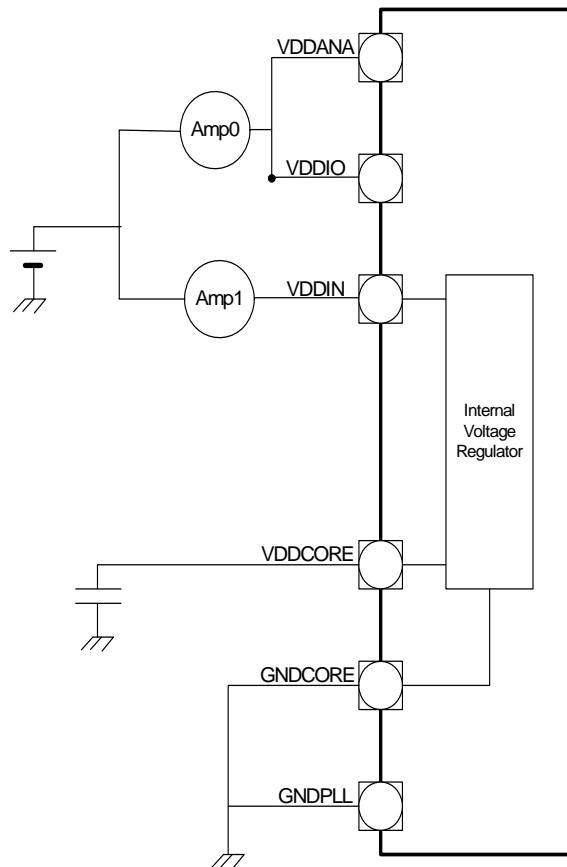

These figures represent the power consumption measured on the power supplies.

Table 10-3. Power Consumption for Different Modes⁽¹⁾

Mode	Conditions		Consumption Typ.	Unit
Active	CPU running from flash. CPU clocked from PLL0 at f MHz Voltage regulator is on. XIN0 : external clock. ⁽¹⁾ XIN1 stopped. XIN32 stopped PLL0 running All peripheral clocks activated. GPIOs on internal pull-up. JTAG unconnected with ext pull-up.	f = 12 MHz	10	mA
		f = 24 MHz	18	mA
		f = 36MHz	27	mA
		f = 50 MHz	34	mA
		f = 60 MHz	42	mA
Static	Typ : Ta = 25 °C CPU is in static mode GPIOs on internal pull-up. All peripheral clocks de-activated. DM and DP pins connected to ground. XIN0,Xin1 and XIN2 are stopped	on Amp0	0	uA
		on Amp1	<100	uA

1. Core frequency is generated from XIN0 using the PLL so that 140 MHz < fpll0 < 160 MHz and 10 MHz < fxin0 < 12MHz

Table 10-4. Power Consumption by Peripheral in Active Mode

Peripheral	Consumption	Unit
GPIO	37	μA/MHz
SMC	10	
SDRAMC	4	
ADC	18	
EBI	31	
INTC	25	
TWI	14	
PDCA	30	
RTC	7	
SPI	13	
SSC	13	
TC	10	
USART	35	

10.5 Clock Characteristics

These parameters are given in the following conditions:

- V_{DCCORE} = 1.8V

- Ambient Temperature = 25°C

10.5.1 CPU/HSB Clock Characteristics

Table 10-5. Core Clock Waveform Parameters

Symbol	Parameter	Conditions	Min	Max	Units
$1/(t_{CPCPU})$	CPU Clock Frequency			66	MHz
t_{CPCPU}	CPU Clock Period		15.5		ns

10.5.2 PBA Clock Characteristics

Table 10-6. PBA Clock Waveform Parameters

Symbol	Parameter	Conditions	Min	Max	Units
$1/(t_{CPPBA})$	PBA Clock Frequency			66	MHz
t_{CPPBA}	PBA Clock Period		15.5		ns

10.5.3 PBB Clock Characteristics

Table 10-7. PBB Clock Waveform Parameters

Symbol	Parameter	Conditions	Min	Max	Units
$1/(t_{CPPBB})$	PBB Clock Frequency			66	MHz
t_{CPPBB}	PBB Clock Period		15.5		ns

10.5.4 XIN Clock Characteristics

Table 10-8. XIN Clock Electrical Characteristics

Symbol	Parameter	Conditions	Min	Max	Units
$1/(t_{CPXIN})$	XIN Clock Frequency		3	24	MHz
t_{CPXIN}	XIN Clock Period		20.0		ns
t_{CHXIN}	XIN Clock High Half-period		$0.4 \times t_{CPXIN}$	$0.6 \times t_{CPXIN}$	
t_{CLXIN}	XIN Clock Low Half-period		$0.4 \times t_{CPXIN}$	$0.6 \times t_{CPXIN}$	
C_{IN}	XIN Input Capacitance	(1)		TBD	pF
R_{IN}	XIN Pulldown Resistor	(1)		TBD	k Ω

Note: 1. These characteristics apply only when the Main Oscillator is in bypass mode (i.e., when MOSCEN = 0 and OSCBYPASS = 1 in the CKGR_MOR register.)

10.6 Crystal Oscillator Characteristics

The following characteristics are applicable to the operating temperature range: $T_A = -40^\circ\text{C}$ to 85°C and worst case of power supply, unless otherwise specified.

10.6.1 32 KHz Oscillator Characteristics

Table 10-9. 32 KHz Oscillator Characteristics

Symbol	Parameter	Conditions	Min	Typ	Max	Unit
$1/(t_{CP32KHz})$	Crystal Oscillator Frequency			32 768		Hz
C_L	Equivalent Load Capacitance		6		12.5	pF
	Duty Cycle		TBD		TBD	%
t_{ST}	Startup Time	$R_S = \text{TBD } k\Omega, C_L = \text{TBD } \mu F^{(1)}$			TBD	ms

Note: 1. R_S is the equivalent series resistance, C_L is the equivalent load capacitance.

10.6.2 Main Oscillators Characteristics

Table 10-10. Main Oscillator Characteristics

Symbol	Parameter	Conditions	Min	Typ	Max	Unit
$1/(t_{CPMAIN})$	Crystal Oscillator Frequency		3		16	MHz
C_{L1}, C_{L2}	Internal Load Capacitance ($C_{L1} = C_{L2}$)			12		pF
C_L	Equivalent Load Capacitance			TBD		pF
	Duty Cycle		40	50	60	%
t_{ST}	Startup Time				TBD	ms
I_{OSC}	Current Consumption	Active mode @TBD MHz			TBD	μA
		Standby mode @TBD V			TBD	μA

Notes: 1. C_S is the shunt capacitance

10.6.3 PLL Characteristics

Table 10-11. Phase Lock Loop Characteristics

Symbol	Parameter	Conditions	Min	Typ	Max	Unit
F_{OUT}	Output Frequency		80		240	MHz
F_{IN}	Input Frequency		TBD		TBD	MHz
I_{PLL}	Current Consumption	active mode			TBD	mA
		standby mode			TBD	μA

Note: 1. Startup time depends on PLL RC filter. A calculation tool is provided by Atmel.

10.7 ADC Characteristics

Table 10-12. Channel Conversion Time and ADC Clock

Parameter	Conditions	Min	Typ	Max	Units
ADC Clock Frequency	10-bit resolution mode			5	MHz
ADC Clock Frequency	8-bit resolution mode			8	MHz
Startup Time	Return from Idle Mode			20	μs
Track and Hold Acquisition Time		600			ns
Conversion Time	ADC Clock = 5 MHz			2	μs
Conversion Time	ADC Clock = 8 MHz			1.25	μs
Throughput Rate	ADC Clock = 5 MHz			384 ⁽¹⁾	kSPS
Throughput Rate	ADC Clock = 8 MHz			533 ⁽²⁾	kSPS

- Notes:
1. Corresponds to 13 clock cycles at 5 MHz: 3 clock cycles for track and hold acquisition time and 10 clock cycles for conversion.
 2. Corresponds to 15 clock cycles at 8 MHz: 5 clock cycles for track and hold acquisition time and 10 clock cycles for conversion.

Table 10-13. Analog Inputs

Parameter	Min	Typ	Max	Units
Input Voltage Range	0		V _{DDANA}	
Input Leakage Current		TBD		μA
Input Capacitance		17		pF

Table 10-14. Transfer Characteristics

Parameter	Conditions	Min	Typ	Max	Units
Resolution			10		Bit
Absolute Accuracy	f=5MHz			0.8	LSB
Integral Non-linearity	f=5MHz		0.35	0.5	LSB
Differential Non-linearity	f=5MHz		0.3	0.5	LSB
Offset Error	f=5MHz	-0.5		0.5	LSB
Gain Error	f=5MHz	-0.5		0.5	LSB

10.8 USB Transceiver Characteristics

10.8.1 Electrical Characteristics

Table 10-15. Electrical Parameters

Symbol	Parameter	Conditions	Min	Typ	Max	Unit
Input Levels						
V_{IL}	Low Level				TBD	V
V_{IH}	High Level		TBD			V
V_{DI}	Differential Input Sensivity	$ (D+) - (D-) $	TBD			V
V_{CM}	Differential Input Common Mode Range		TBD		TBD	V
C_{IN}	Transceiver capacitance	Capacitance to ground on each line			TBD	pF
I	Hi-Z State Data Line Leakage	$0V < V_{IN} < 3.3V$	TBD		TBD	μA
R_{EXT}	Recommended External USB Series Resistor	In series with each USB pin with $\pm 5\%$		TBD		Ω
Output Levels						
V_{OL}	Low Level Output	Measured with R_L of 1.425 k Ω tied to 3.6V	TBD		TBD	V
V_{OH}	High Level Output	Measured with R_L of 14.25 k Ω tied to GND	TBD		TBD	V
V_{CRS}	Output Signal Crossover Voltage		TBD		TBD	V

10.8.2 Switching Characteristics

Table 10-16. In Low Speed

Symbol	Parameter	Conditions	Min	Typ	Max	Unit
t_{FR}	Transition Rise Time	$C_{LOAD} = 400$ pF	TBD		TBD	ns
t_{FE}	Transition Fall Time	$C_{LOAD} = 400$ pF	TBD		TBD	ns
t_{FRFM}	Rise/Fall time Matching	$C_{LOAD} = 400$ pF	TBD		TBD	%

Table 10-17. In Full Speed

Symbol	Parameter	Conditions	Min	Typ	Max	Unit
t_{FR}	Transition Rise Time	$C_{LOAD} = 50$ pF	TBD		TBD	ns
t_{FE}	Transition Fall Time	$C_{LOAD} = 50$ pF	TBD		TBD	ns
t_{FRFM}	Rise/Fall time Matching		TBD		TBD	%

10.9 EBI Timings

These timings are given for worst case process, T = 85-C, VDDCORE = 1.65V, VDDIO = 3V and 40 pF load capacitance.

Table 10-18. SMC Clock Signal.

Symbol	Parameter	Max ⁽¹⁾	Units
1/(t _{CPSMC})	SMC Controller Clock Frequency	1/(t _{cpu})	MHz

Note: 1. The maximum frequency of the SMC interface is the same as the max frequency for the HSB.

Table 10-19. SMC Read Signals with Hold Settings

Symbol	Parameter	Min	Units
NRD Controlled (READ_MODE = 1)			
SMC ₁	Data Setup before NRD High	12	ns
SMC ₂	Data Hold after NRD High	0	
SMC ₃	NRD High to NBS0/A0 Change ⁽¹⁾	nrd hold length * t _{CPSMC} - 1.3	
SMC ₄	NRD High to NBS1 Change ⁽¹⁾	nrd hold length * t _{CPSMC} - 1.3	
SMC ₅	NRD High to NBS2/A1 Change ⁽¹⁾	nrd hold length * t _{CPSMC} - 1.3	
SMC ₇	NRD High to A2 - A23 Change ⁽¹⁾	nrd hold length * t _{CPSMC} - 1.3	
SMC ₈	NRD High to NCS Inactive ⁽¹⁾	(nrd hold length - ncs rd hold length) * t _{CPSMC} - 2.3	
SMC ₉	NRD Pulse Width	nrd pulse length * t _{CPSMC} - 1.4	
NRD Controlled (READ_MODE = 0)			
SMC ₁₀	Data Setup before NCS High	11.5	ns
SMC ₁₁	Data Hold after NCS High	0	
SMC ₁₂	NCS High to NBS0/A0 Change ⁽¹⁾	ncs rd hold length * t _{CPSMC} - 2.3	
SMC ₁₃	NCS High to NBS0/A0 Change ⁽¹⁾	ncs rd hold length * t _{CPSMC} - 2.3	
SMC ₁₄	NCS High to NBS2/A1 Change ⁽¹⁾	ncs rd hold length * t _{CPSMC} - 2.3	
SMC ₁₆	NCS High to A2 - A23 Change ⁽¹⁾	ncs rd hold length * t _{CPSMC} - 4	
SMC ₁₇	NCS High to NRD Inactive ⁽¹⁾	ncs rd hold length - nrd hold length) * t _{CPSMC} - 1.3	
SMC ₁₈	NCS Pulse Width	ncs rd pulse length * t _{CPSMC} - 3.6	

Note: 1. hold length = total cycle duration - setup duration - pulse duration. "hold length" is for "ncs rd hold length" or "nrd hold length".

Table 10-20. SMC Read Signals with no Hold Settings

Symbol	Parameter	Min	Units
NRD Controlled (READ_MODE = 1)			
SMC ₁₉	Data Setup before NRD High	13.7	ns
SMC ₂₀	Data Hold after NRD High	1	
NRD Controlled (READ_MODE = 0)			
SMC ₂₁	Data Setup before NCS High	13.3	ns
SMC ₂₂	Data Hold after NCS High	0	

Table 10-21. SMC Write Signals with Hold Settings

Symbol	Parameter	Min	Units
NRD Controlled (READ_MODE = 1)			
SMC ₂₃	Data Out Valid before NWE High	$(nwe \text{ pulse length} - 1) * t_{CPSMC} - 0.9$	ns
SMC ₂₄	Data Out Valid after NWE High ⁽¹⁾	$nwe \text{ hold length} * t_{CPSMC} - 6$	
SMC ₂₅	NWE High to NBS0/A0 Change ⁽¹⁾	$nwe \text{ hold length} * t_{CPSMC} - 1.9$	
SMC ₂₆	NWE High to NBS1 Change ⁽¹⁾	$nwe \text{ hold length} * t_{CPSMC} - 1.9$	
SMC ₂₉	NWE High to A1 Change ⁽¹⁾	$nwe \text{ hold length} * t_{CPSMC} - 1.9$	
SMC ₃₁	NWE High to A2 - A23 Change ⁽¹⁾	$nwe \text{ hold length} * t_{CPSMC} - 1.7$	
SMC ₃₂	NWE High to NCS Inactive ⁽¹⁾	$(nwe \text{ hold length} - ncs \text{ wr hold length}) * t_{CPSMC} - 2.9$	
SMC ₃₃	NWE Pulse Width	$nwe \text{ pulse length} * t_{CPSMC} - 0.9$	
NRD Controlled (READ_MODE = 0)			
SMC ₃₄	Data Out Valid before NCS High	$(ncs \text{ wr pulse length} - 1) * t_{CPSMC} - 4.6$	ns
SMC ₃₅	Data Out Valid after NCS High ⁽¹⁾	$ncs \text{ wr hold length} * t_{CPSMC} - 5.8$	
SMC ₃₆	NCS High to NWE Inactive ⁽¹⁾	$(ncs \text{ wr hold length} - nwe \text{ hold length}) * t_{CPSMC} - 0.6$	

Note: 1. hold length = total cycle duration - setup duration - pulse duration. "hold length" is for "ncs wr hold length" or "nwe hold length"

Table 10-22. SMC Write Signals with No Hold Settings (NWE Controlled only).

Symbol	Parameter	Min	Units
SMC ₃₇	NWE Rising to A2-A25 Valid	5.4	ns
SMC ₃₈	NWE Rising to NBS0/A0 Valid	5	
SMC ₃₉	NWE Rising to NBS1 Change	5	
SMC ₄₀	NWE Rising to A1/NBS2 Change	5	
SMC ₄₁	NWE Rising to NBS3 Change	5	
SMC ₄₂	NWE Rising to NCS Rising	5.1	
SMC ₄₃	Data Out Valid before NWE Rising	$(nwe\ pulse\ length - 1) * t_{CPSMC} - 1.2$	
SMC ₄₄	Data Out Valid after NWE Rising	5	
SMC ₄₅	NWE Pulse Width	$nwe\ pulse\ length * t_{CPSMC} - 0.9$	

Figure 10-2. SMC Signals for NCS Controlled Accesses.

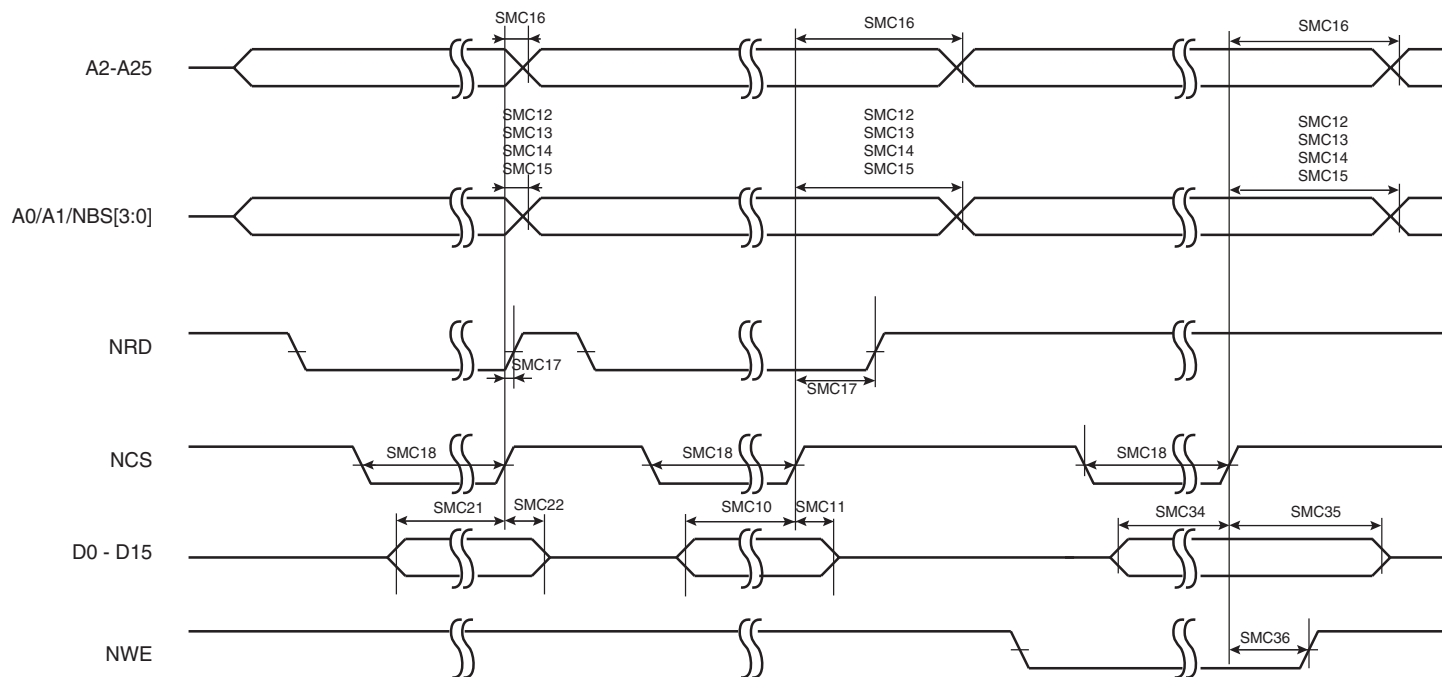
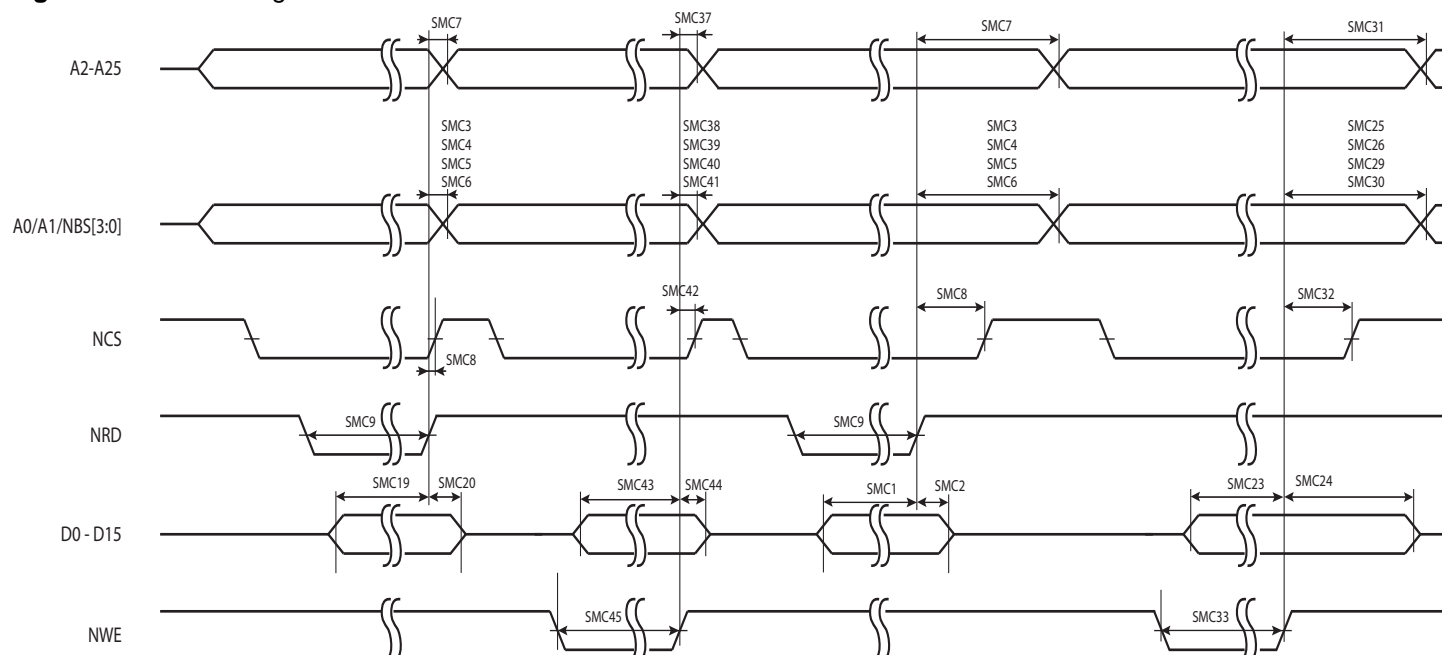

Figure 10-3. SMC Signals for NRD and NRW Controlled Accesses.



10.9.1 SDRAM Signals

These timings are given for 10 pF load on SDCK and 40 pF on other signals.

Table 10-23. SDRAM Clock Signal.

Symbol	Parameter	Max ⁽¹⁾	Units
$1/(t_{CPDCK})$	SDRAM Controller Clock Frequency	$1/(t_{cpCPU})$	MHz

Note: 1. The maximum frequency of the SDRAMC interface is the same as the max frequency for the HSB.

Table 10-24. SDRAM Clock Signal.

Symbol	Parameter	Min	Units
SDRAMC ₁	SDCKE High before SDCK Rising Edge	7.4	ns
SDRAMC ₂	SDCKE Low after SDCK Rising Edge	3.2	
SDRAMC ₃	SDCKE Low before SDCK Rising Edge	7	
SDRAMC ₄	SDCKE High after SDCK Rising Edge	2.9	
SDRAMC ₅	SDCS Low before SDCK Rising Edge	7.5	
SDRAMC ₆	SDCS High after SDCK Rising Edge	1.6	
SDRAMC ₇	RAS Low before SDCK Rising Edge	7.2	
SDRAMC ₈	RAS High after SDCK Rising Edge	2.3	
SDRAMC ₉	SDA10 Change before SDCK Rising Edge	7.6	
SDRAMC ₁₀	SDA10 Change after SDCK Rising Edge	1.9	

Table 10-24. SDRAM Clock Signal.

Symbol	Parameter	Min	Units
SDRAMC ₁₁	Address Change before SDCK Rising Edge	6.2	ns
SDRAMC ₁₂	Address Change after SDCK Rising Edge	2.2	
SDRAMC ₁₃	Bank Change before SDCK Rising Edge	6.3	
SDRAMC ₁₄	Bank Change after SDCK Rising Edge	2.4	
SDRAMC ₁₅	CAS Low before SDCK Rising Edge	7.4	
SDRAMC ₁₆	CAS High after SDCK Rising Edge	1.9	
SDRAMC ₁₇	DQM Change before SDCK Rising Edge	6.4	
SDRAMC ₁₈	DQM Change after SDCK Rising Edge	2.2	
SDRAMC ₁₉	D0-D15 in Setup before SDCK Rising Edge	9	
SDRAMC ₂₀	D0-D15 in Hold after SDCK Rising Edge	0	
SDRAMC ₂₃	SDWE Low before SDCK Rising Edge	7.6	
SDRAMC ₂₄	SDWE High after SDCK Rising Edge	1.8	
SDRAMC ₂₅	D0-D15 Out Valid before SDCK Rising Edge	7.1	
SDRAMC ₂₆	D0-D15 Out Valid after SDCK Rising Edge	1.5	

Figure 10-4. SDRAMC Signals relative to SDCK.

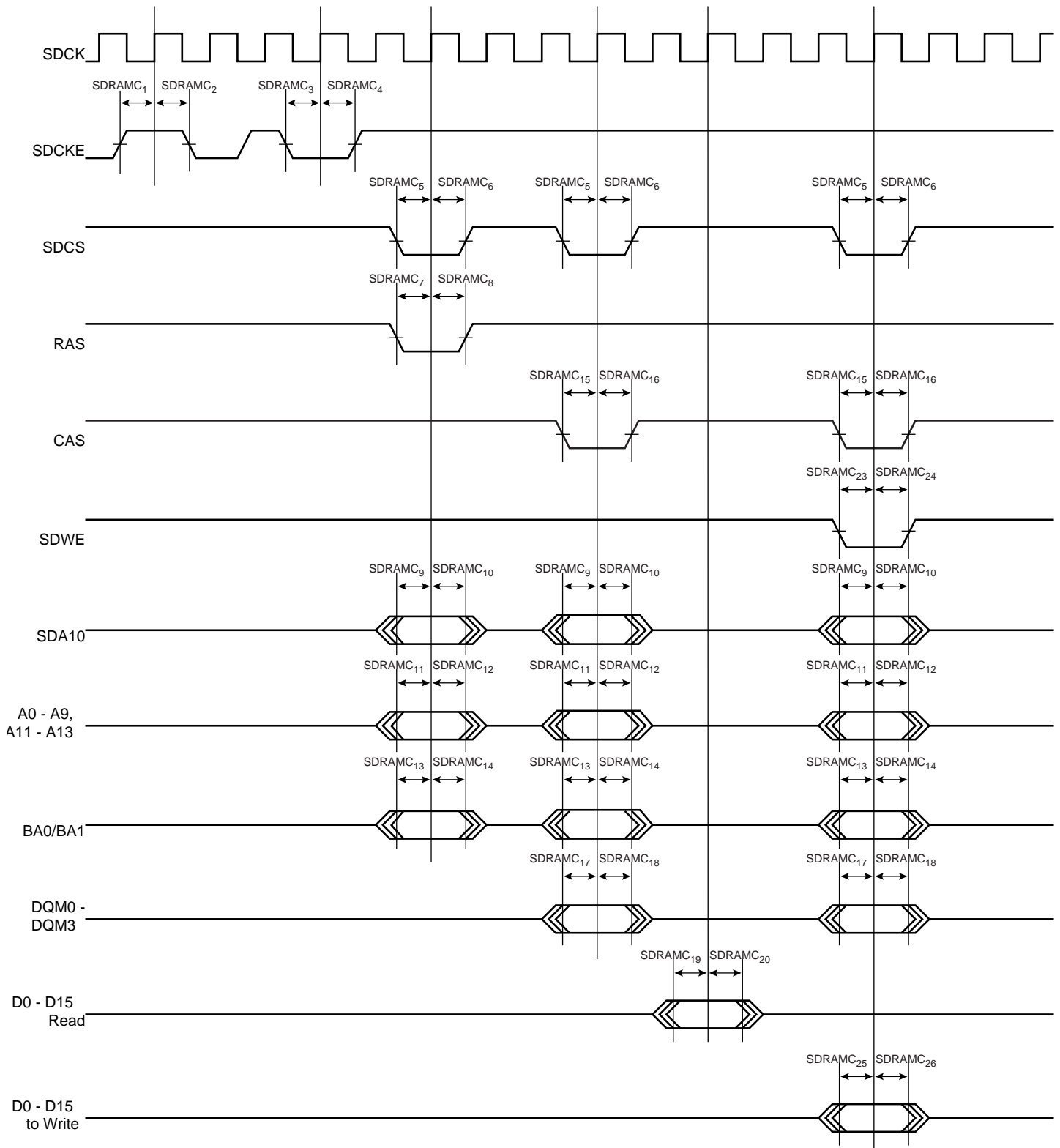

10.10 JTAG Timings

10.10.1 JTAG Interface Signals

Table 10-25. JTAG Interface Timing specification

Symbol	Parameter	Conditions	Min	Max	Units
JTAG ₀	TCK Low Half-period	(1)	6		ns
JTAG ₁	TCK High Half-period	(1)	3		ns
JTAG ₂	TCK Period	(1)	9		ns
JTAG ₃	TDI, TMS Setup before TCK High	(1)	1		ns
JTAG ₄	TDI, TMS Hold after TCK High	(1)	0		ns
JTAG ₅	TDO Hold Time	(1)	4		ns
JTAG ₆	TCK Low to TDO Valid	(1)		6	ns
JTAG ₇	Device Inputs Setup Time	(1)			ns
JTAG ₈	Device Inputs Hold Time	(1)			ns
JTAG ₉	Device Outputs Hold Time	(1)			ns
JTAG ₁₀	TCK to Device Outputs Valid	(1)			ns

Note: 1. V_{DDIO} from 3.0V to 3.6V, maximum external capacitor = 40pF

Figure 10-5. JTAG Interface Signals

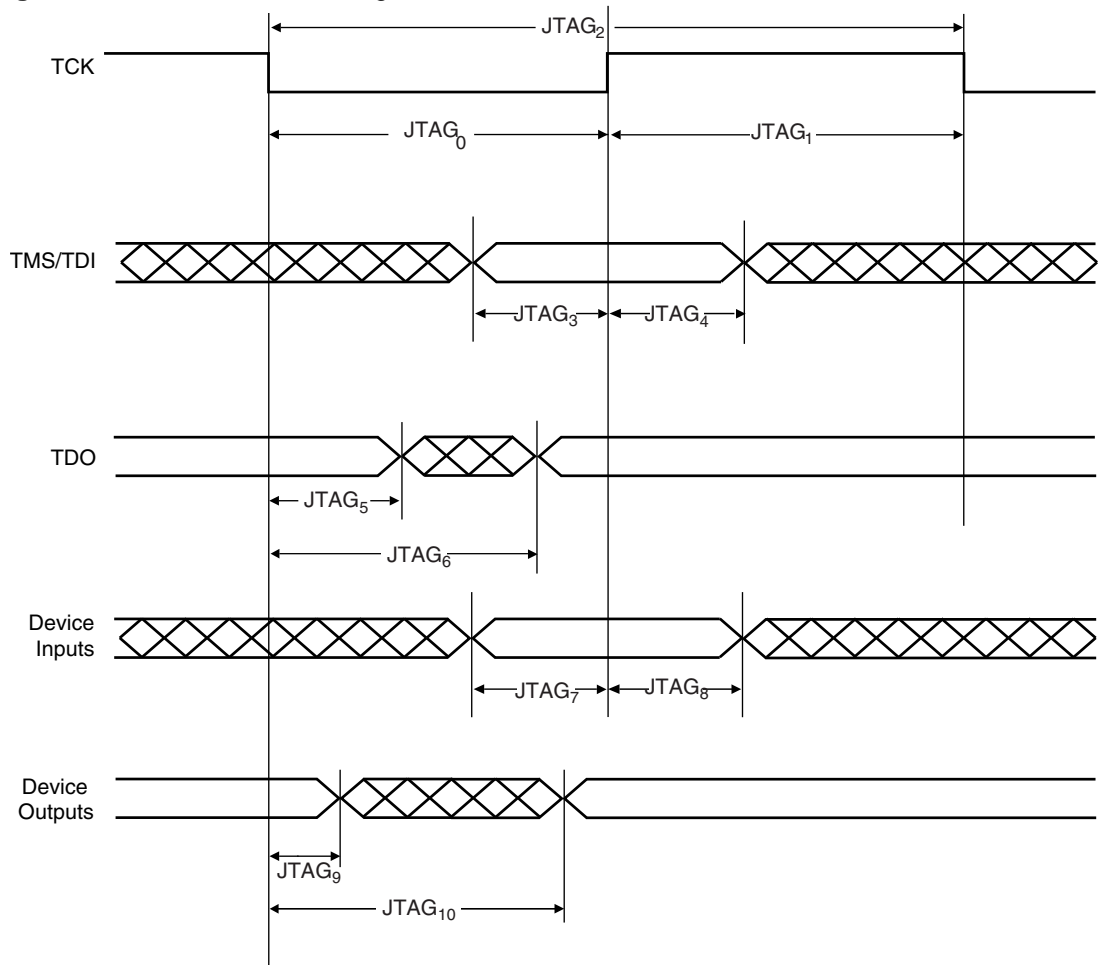

10.11 SPI Characteristics

Figure 10-6. SPI Master mode with (CPOL = NCPHA = 0) or (CPOL= NCPHA= 1)

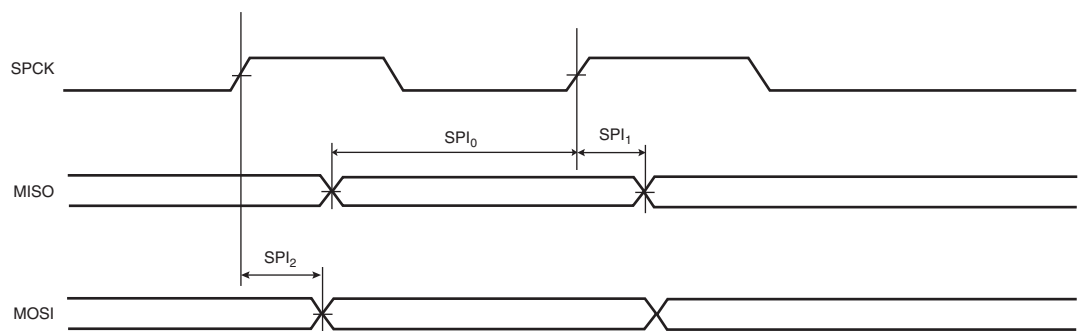

Figure 10-7. SPI Master mode with (CPOL=0 and NCPHA=1) or (CPOL=1 and NCPHA=0)

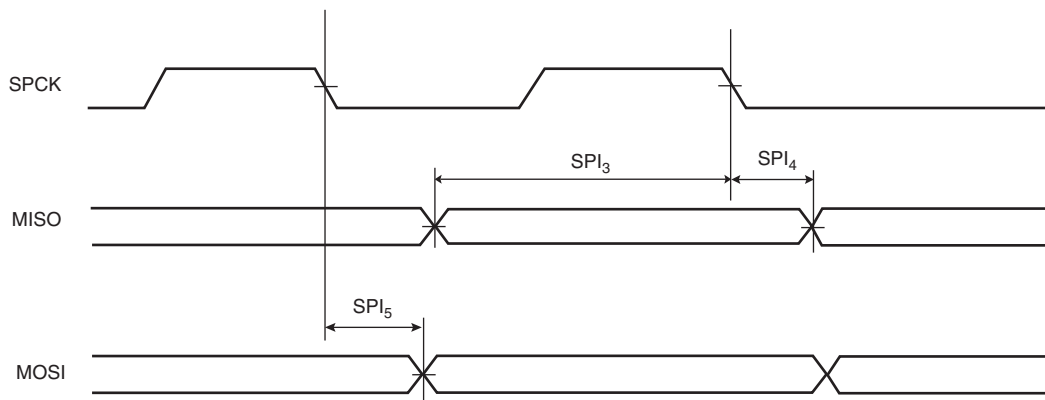

Figure 10-8. SPI Slave mode with (CPOL=0 and NCPHA=1) or (CPOL=1 and NCPHA=0)

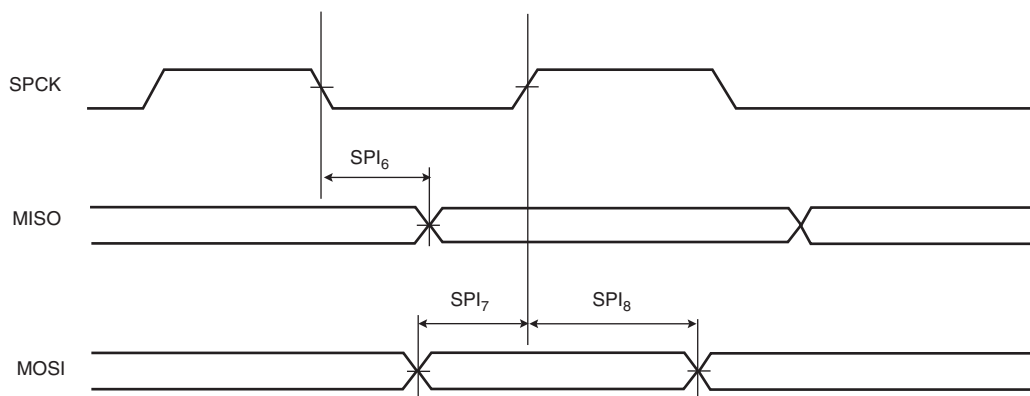

Figure 10-9. SPI Slave mode with (CPOL = NCPHA = 0) or (CPOL= NCPHA= 1)

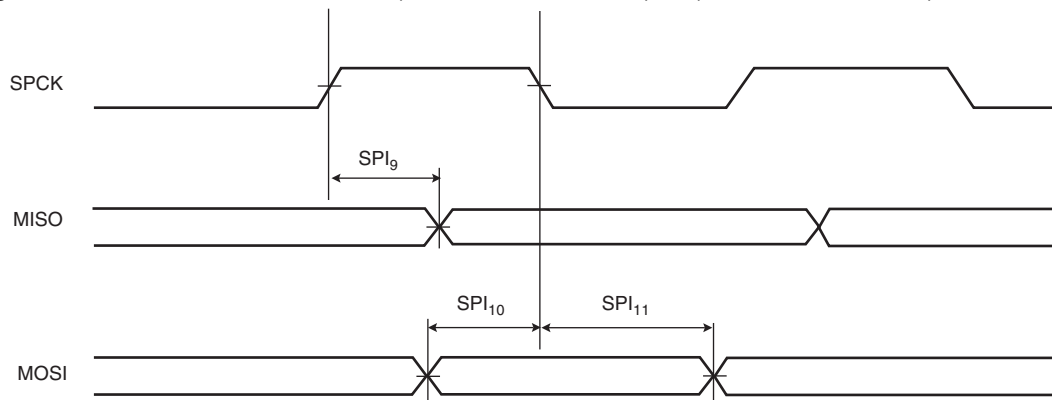

Table 10-26. SPI Timings

Symbol	Parameter	Conditions	Min	Max	Units
SPI ₀	MISO Setup time before SPCK rises (master)	3.3V domain ⁽¹⁾	22 + (t _{CPMCK})/2 ⁽²⁾		ns
SPI ₁	MISO Hold time after SPCK rises (master)	3.3V domain ⁽¹⁾	0		ns
SPI ₂	SPCK rising to MOSI Delay (master)	3.3V domain ⁽¹⁾		7	ns
SPI ₃	MISO Setup time before SPCK falls (master)	3.3V domain ⁽¹⁾	22 + (t _{CPMCK})/2 ⁽²⁾		ns
SPI ₄	MISO Hold time after SPCK falls (master)	3.3V domain ⁽¹⁾	0		ns
SPI ₅	SPCK falling to MOSI Delay (master)	3.3V domain ⁽¹⁾		7	ns
SPI ₆	SPCK falling to MISO Delay (slave)	3.3V domain ⁽¹⁾		26.5	ns
SPI ₇	MOSI Setup time before SPCK rises (slave)	3.3V domain ⁽¹⁾	0		ns
SPI ₈	MOSI Hold time after SPCK rises (slave)	3.3V domain ⁽¹⁾	1.5		ns
SPI ₉	SPCK rising to MISO Delay (slave)	3.3V domain ⁽¹⁾		27	ns
SPI ₁₀	MOSI Setup time before SPCK falls (slave)	3.3V domain ⁽¹⁾	0		ns
SPI ₁₁	MOSI Hold time after SPCK falls (slave)	3.3V domain ⁽¹⁾	1		ns

Notes: 1. 3.3V domain: V_{VDDIO} from 3.0V to 3.6V, maximum external capacitor = 40 pF.
 2. t_{CPMCK}: Master Clock period in ns.

10.12 MACB Characteristics

Table 10-27. Ethernet MAC Signals

Symbol	Parameter	Conditions	Min (ns)	Max (ns)
EMAC ₁	Setup for EMDIO from EMDC rising	Load: 20pF ⁽²⁾		
EMAC ₂	Hold for EMDIO from EMDC rising	Load: 20pF ⁽²⁾		
EMAC ₃	EMDIO toggling from EMDC falling	Load: 20pF ⁽²⁾		

Notes: 1. f: MCK frequency (MHz)
 2. V_{VDDIO} from 3.0V to 3.6V, maximum external capacitor = 20 pF

Table 10-28. Ethernet MAC MII Specific Signals

Symbol	Parameter	Conditions	Min (ns)	Max (ns)
EMAC ₄	Setup for ECOL from ETXCK rising	Load: 20pF ⁽¹⁾	3	
EMAC ₅	Hold for ECOL from ETXCK rising	Load: 20pF ⁽¹⁾	0	
EMAC ₆	Setup for ECRS from ETXCK rising	Load: 20pF ⁽¹⁾	3	
EMAC ₇	Hold for ECRS from ETXCK rising	Load: 20pF ⁽¹⁾	0	
EMAC ₈	ETXER toggling from ETXCK rising	Load: 20pF ⁽¹⁾		15
EMAC ₉	ETXEN toggling from ETXCK rising	Load: 20pF ⁽¹⁾		15
EMAC ₁₀	ETX toggling from ETXCK rising	Load: 20pF ⁽¹⁾		15
EMAC ₁₁	Setup for ERX from ERXCK	Load: 20pF ⁽¹⁾	1	

Table 10-28. Ethernet MAC MII Specific Signals

Symbol	Parameter	Conditions	Min (ns)	Max (ns)
EMAC ₁₂	Hold for ERX from ERXCK	Load: 20pF ⁽¹⁾	1.5	
EMAC ₁₃	Setup for ERXER from ERXCK	Load: 20pF ⁽¹⁾	1	
EMAC ₁₄	Hold for ERXER from ERXCK	Load: 20pF ⁽¹⁾	0.5	
EMAC ₁₅	Setup for ERXDV from ERXCK	Load: 20pF ⁽¹⁾	1.5	
EMAC ₁₆	Hold for ERXDV from ERXCK	Load: 20pF ⁽¹⁾	1	

Note: 1. V_{VDDIO} from 3.0V to 3.6V, maximum external capacitor = 20 pF

Figure 10-10. Ethernet MAC MII Mode

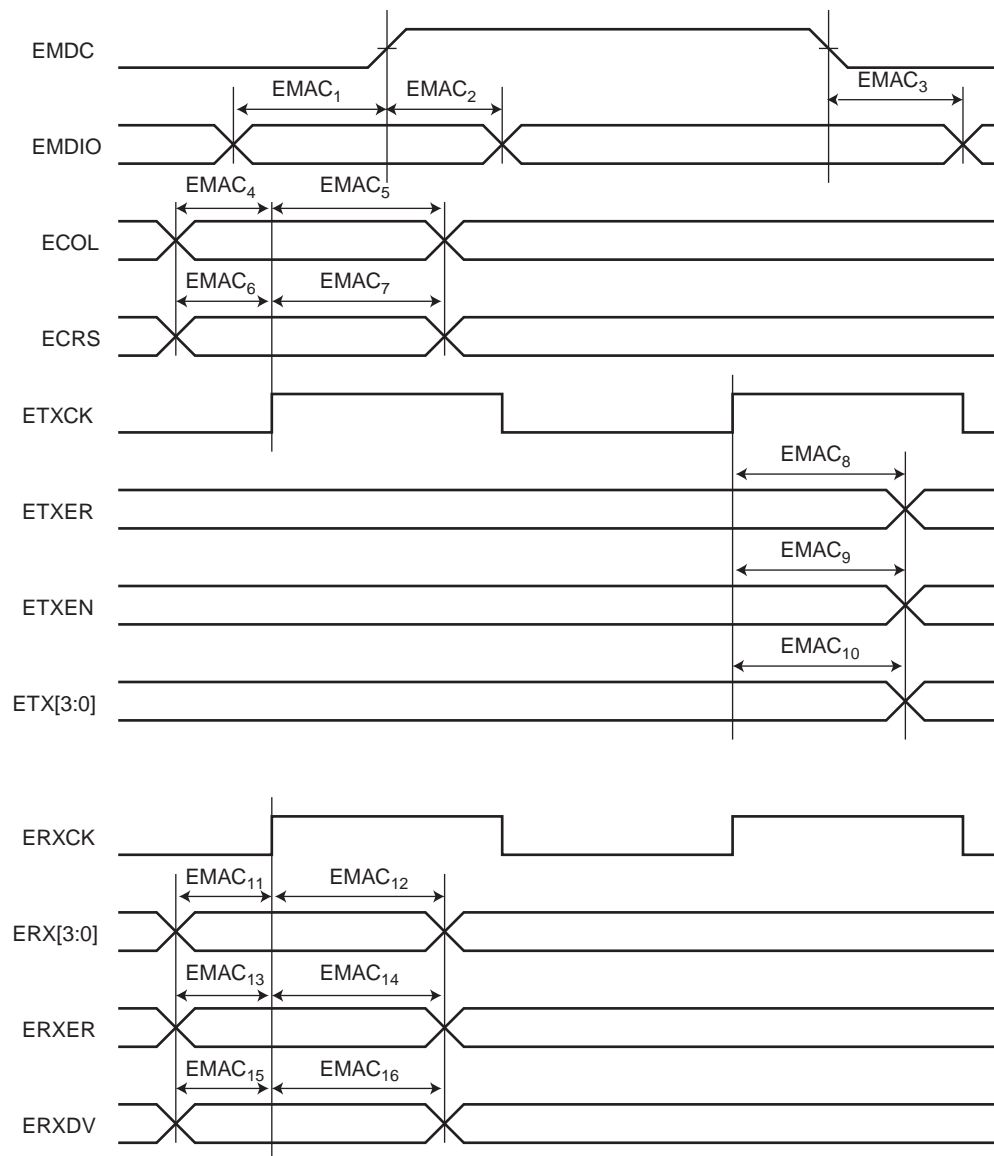
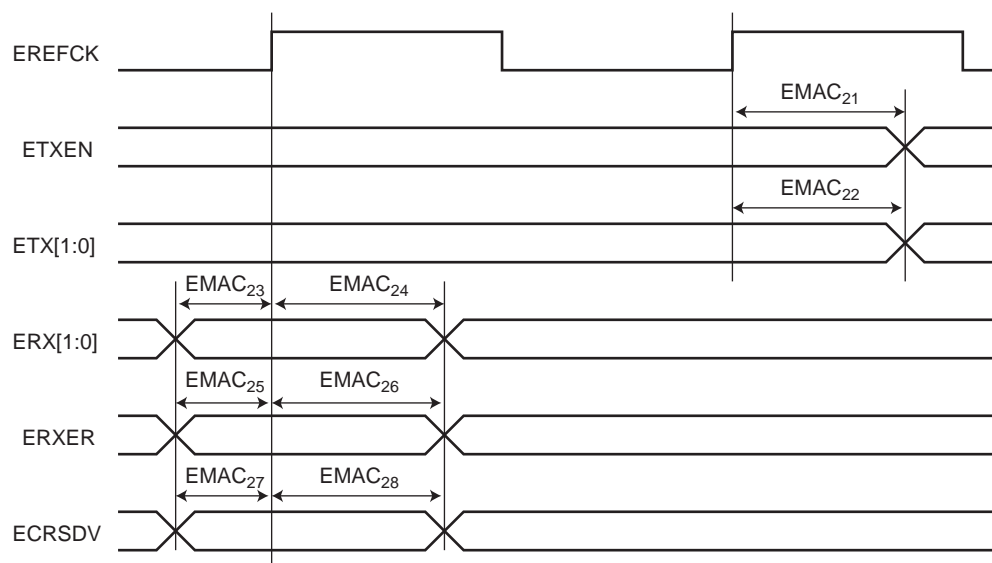

Table 10-29. Ethernet MAC RMII Specific Signals

Symbol	Parameter	Min (ns)	Max (ns)
EMAC ₂₁	ETXEN toggling from EREFCK rising	7	14.5
EMAC ₂₂	ETX toggling from EREFCK rising	7	14.7
EMAC ₂₃	Setup for ERX from EREFCK	1.5	
EMAC ₂₄	Hold for ERX from EREFCK	0	
EMAC ₂₅	Setup for ERXER from EREFCK	1.5	
EMAC ₂₆	Hold for ERXER from EREFCK	0	
EMAC ₂₇	Setup for ECRSDV from EREFCK	1.5	
EMAC ₂₈	Hold for ECRSDV from EREFCK	0	

Figure 10-11. Ethernet MAC RMII Mode



10.13 Flash Characteristics

The following table gives the device maximum operating frequency depending on the field FWS of the Flash FSR register. This field defines the number of wait states required to access the Flash Memory.

Table 10-30. Flash Wait States

FWS	Read Operations	Maximum Operating Frequency (MHz)
0	1 cycle	36
1	2 cycles	66

11. Mechanical Characteristics

11.1 Thermal Considerations

11.1.1 Thermal Data

Table 11-1 summarizes the thermal resistance data depending on the package.

Table 11-1. Thermal Resistance Data

Symbol	Parameter	Condition	Package	Typ	Unit
θ_{JA}	Junction-to-ambient thermal resistance	Still Air	TQFP144	TBD	°C/W
θ_{JC}	Junction-to-case thermal resistance		TQFP144	TBD	
θ_{JA}	Junction-to-ambient thermal resistance	Still Air	TBGA144	TBD	°C/W
θ_{JC}	Junction-to-case thermal resistance		TBGA144	TBD	

11.1.2 Junction Temperature

The average chip-junction temperature, T_J , in °C can be obtained from the following:

1. $T_J = T_A + (P_D \times \theta_{JA})$
2. $T_J = T_A + (P_D \times (\theta_{HEATSINK} + \theta_{JC}))$

where:

- θ_{JA} = package thermal resistance, Junction-to-ambient (°C/W), provided in [Table 11-1 on page 65](#).
- θ_{JC} = package thermal resistance, Junction-to-case thermal resistance (°C/W), provided in [Table 11-1 on page 65](#).
- $\theta_{HEAT\ SINK}$ = cooling device thermal resistance (°C/W), provided in the device datasheet.
- P_D = device power consumption (W) estimated from data provided in the section "[Regulator characteristics](#)" on [page 46](#).
- T_A = ambient temperature (°C).

From the first equation, the user can derive the estimated lifetime of the chip and decide if a cooling device is necessary or not. If a cooling device is to be fitted on the chip, the second equation should be used to compute the resulting average chip-junction temperature T_J in °C.

11.2 Package Drawings

Figure 11-1. TBGA 144 package drawing

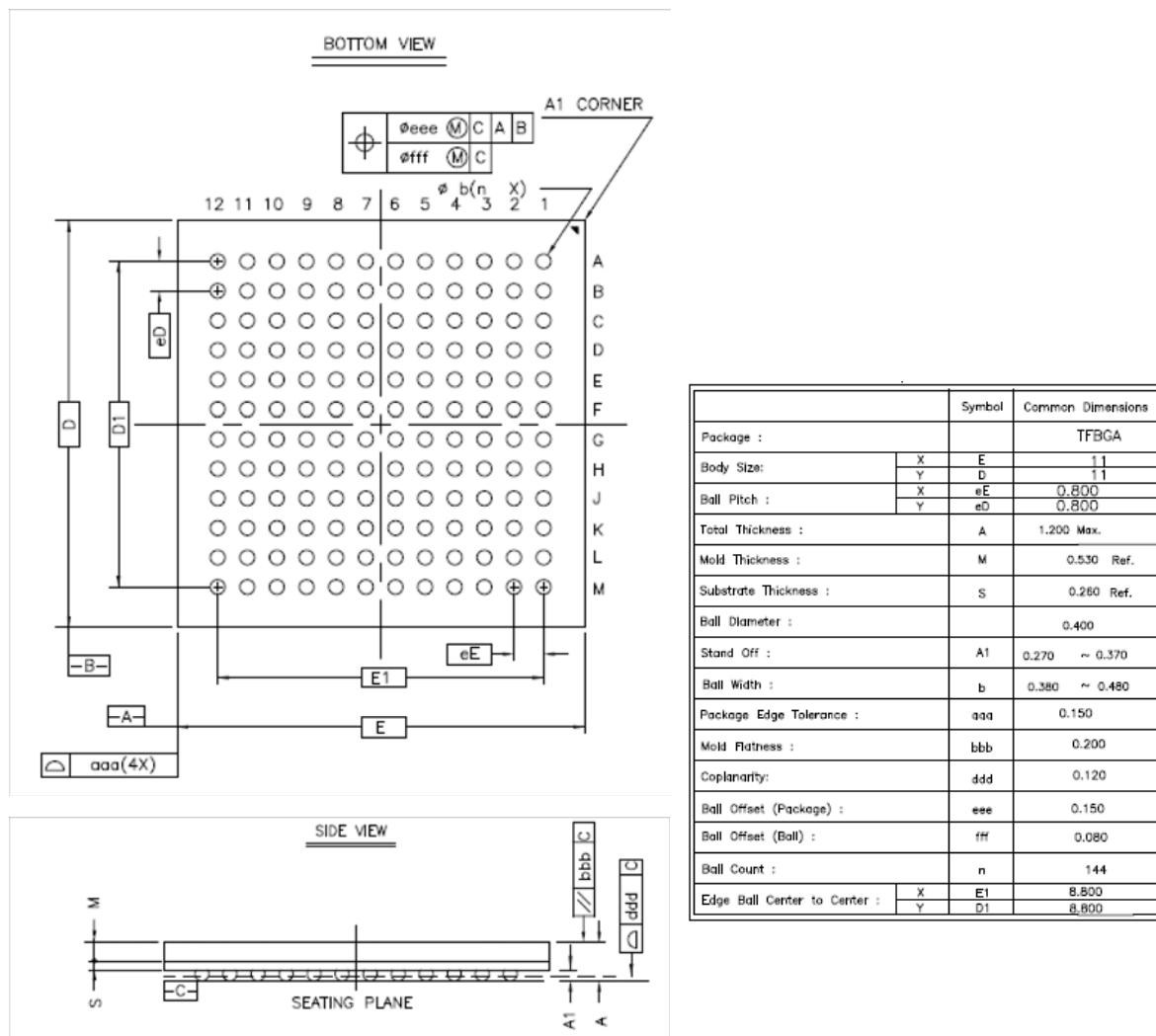
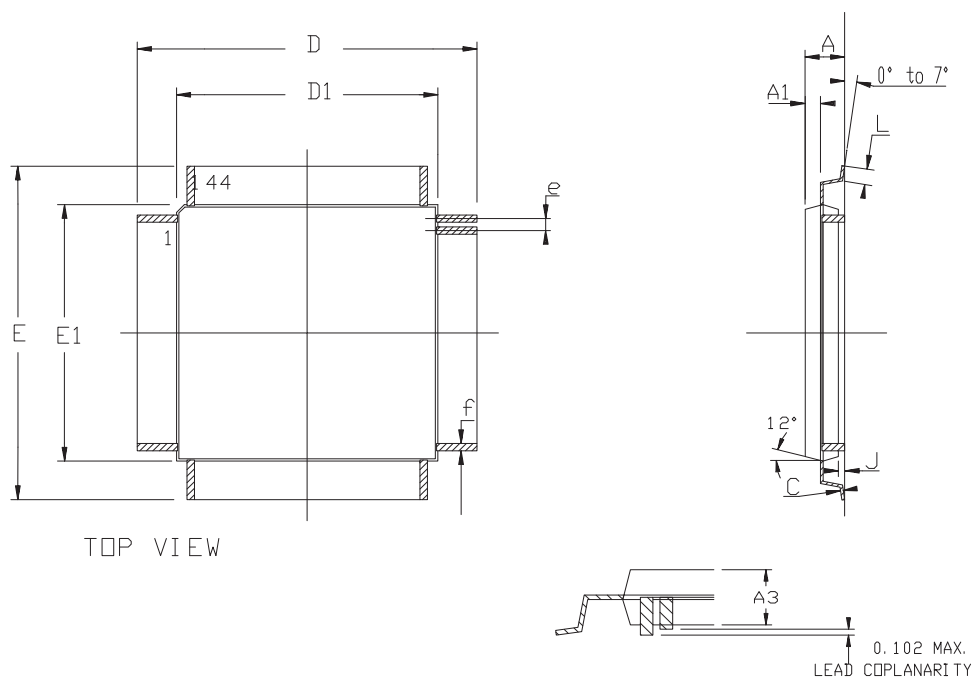

Figure 11-2. LQFP-144 package drawing



	MM		INCH	
	Min	Max	Min	Max
A	-	1.60	-	.063
C	0.09	0.20	.004	.008
A3	1.35	1.45	.053	.057
D	21.90	22.10	.862	.870
D1	19.90	20.10	.783	.791
E	21.90	22.10	.862	.870
E1	19.90	20.10	.783	.791
J	0.05	0.15	.002	.006
L	0.45	0.75	.018	.030
e	0.50 BSC		.0197 BSC	
f	0.22 BSC		.009 BSC	

Table 11-2. Device and Package Maximum Weight

TBD	mg
-----	----

Table 11-3. Package Characteristics

Moisture Sensitivity Level	TBD
----------------------------	-----

Table 11-4. Package Reference

JEDEC Drawing Reference	MS-026
JESD97 Classification	E3

Table 11-5. Device and Package Maximum Weight

TBD	mg
-----	----

11.3 Soldering Profile

Table 11-6 gives the recommended soldering profile from J-STD-20.

Table 11-6. Soldering Profile

Profile Feature	Green Package
Average Ramp-up Rate (217°C to Peak)	TBD
Preheat Temperature 175°C ±25°C	TBD
Temperature Maintained Above 217°C	TBD
Time within 5°C of Actual Peak Temperature	TBD
Peak Temperature Range	TBD
Ramp-down Rate	TBD
Time 25°C to Peak Temperature	TBD

Note: It is recommended to apply a soldering temperature higher than 250°C. A maximum of three reflow passes is allowed per component.

12. Ordering Information

Device	Ordering Code	Package	Conditioning	Temperature Operating Range
AT32UC3A3256S	AT32UC3A3256S-ALUT	144 lead LQFP	Tray	Industrial (-40-C to 85-C)
	AT32UC3A3256S-ALUR	144 lead LQFP	Reels	Industrial (-40-C to 85-C)
	AT32UC3A3256S-CTUT	144 balls TBGA	Tray	Industrial (-40-C to 85-C)
	AT32UC3A3256S-CTUR	144 balls TBGA	Reels	Industrial (-40-C to 85-C)
AT32UC3A3256	AT32UC3A3256-ALUT	144 lead LQFP	Tray	Industrial (-40-C to 85-C)
	AT32UC3A3256-ALUR	144 lead LQFP	Reels	Industrial (-40-C to 85-C)
	AT32UC3A3256-CTUT	144 balls TBGA	Tray	Industrial (-40-C to 85-C)
	AT32UC3A3256-CTUR	144 balls TBGA	Reels	Industrial (-40-C to 85-C)
AT32UC3A3128S	AT32UC3A3128S-ALUT	144 lead LQFP	Tray	Industrial (-40-C to 85-C)
	AT32UC3A3128S-ALUR	144 lead LQFP	Reels	Industrial (-40-C to 85-C)
	AT32UC3A3128S-CTUT	144 balls TBGA	Tray	Industrial (-40-C to 85-C)
	AT32UC3A3128S-CTUR	144 balls TBGA	Reels	Industrial (-40-C to 85-C)
AT32UC3A3128	AT32UC3A3128-ALUT	144 lead LQFP	Tray	Industrial (-40-C to 85-C)
	AT32UC3A3128-ALUR	144 lead LQFP	Reels	Industrial (-40-C to 85-C)
	AT32UC3A3128-CTUT	144 balls TBGA	Tray	Industrial (-40-C to 85-C)
	AT32UC3A3128-CTUR	144 balls TBGA	Reels	Industrial (-40-C to 85-C)
AT32UC3A364S	AT32UC3A364S-ALUT	144 lead LQFP	Tray	Industrial (-40-C to 85-C)
	AT32UC3A364S-ALUR	144 lead LQFP	Reels	Industrial (-40-C to 85-C)
	AT32UC3A364S-CTUT	144 balls TBGA	Tray	Industrial (-40-C to 85-C)
	AT32UC3A364S-CTUR	144 balls TBGA	Reels	Industrial (-40-C to 85-C)
AT32UC3A364	AT32UC3A364-ALUT	144 lead LQFP	Tray	Industrial (-40-C to 85-C)
	AT32UC3A364-ALUR	144 lead LQFP	Reels	Industrial (-40-C to 85-C)
	AT32UC3A364-CTUT	144 balls TBGA	Tray	Industrial (-40-C to 85-C)
	AT32UC3A364-CTUR	144 balls TBGA	Reels	Industrial (-40-C to 85-C)

13. Errata

13.1 Rev. E

13.1.1 Processor and Architecture

1. **LDM instruction with PC in the register list and without ++ increments Rp**

For LDM with PC in the register list: the instruction behaves as if the ++ field is always set, ie the pointer is always updated. This happens even if the ++ field is cleared. Specifically, the increment of the pointer is done in parallel with the testing of R12.

Fix/Workaround

None.

13.1.2 ADC

1. **Sleep Mode activation needs additional A to D conversion**

If the ADC sleep mode is activated when the ADC is idle the ADC will not enter sleep mode before after the next AD conversion.

Fix/Workaround

Activate the sleep mode in the mode register and then perform an AD conversion.

13.1.3 SPI

1. **SPI Bad Serial Clock Generation on 2nd chip_select when SCBR = 1, CPOL=1 and NCPHA=0**

When multiple CS are in use, if one of the baudrate equals to 1 and one of the others doesn't equal to 1, and CPOL=1 and CPHA=0, then an additional pulse will be generated on SCK.

Fix/workaround

When multiple CS are in use, if one of the baudrate equals 1, the other must also equal 1 if CPOL=1 and CPHA=0.

2. **SPI Disable does not work in Slave mode**

Fix/workaround

Read the last received data then perform a Software reset.

13.2 Rev. D

13.2.1 Processor and Architecture

1. **LDM instruction with PC in the register list and without ++ increments Rp**

For LDM with PC in the register list: the instruction behaves as if the ++ field is always set, ie the pointer is always updated. This happens even if the ++ field is cleared. Specifically, the increment of the pointer is done in parallel with the testing of R12.

Fix/Workaround

None.

2. **RETE instruction does not clear SREG[L] from interrupts.**

The RETE instruction clears SREG[L] as expected from exceptions.

Fix/Workaround



When using the STCOND instruction, clear SREG[L] in the stacked value of SR before returning from interrupts with RETE.

3. Exceptions when system stack is protected by MPU

RETS behaves incorrectly when MPU is enabled and MPU is configured so that system stack is not readable in unprivileged mode.

Fix/Workaround

Workaround 1: Make system stack readable in unprivileged mode,
or

Workaround 2: Return from supervisor mode using rete instead of rets. This requires :

1. Changing the mode bits from 001b to 110b before issuing the instruction.

Updating the mode bits to the desired value must be done using a single mtsr instruction so it is done atomically. Even if this step is described in general as not safe in the UC technical reference guide, it is safe in this very specific case.

2. Execute the RETE instruction.

4. Multiply instructions do not work on RevD.

All the multiply instructions do not work.

Fix/Workaround

Do not use the multiply instructions.

13.2.2 ADC

1. Sleep Mode activation needs additional A to D conversion

If the ADC sleep mode is activated when the ADC is idle the ADC will not enter sleep mode before after the next AD conversion.

Fix/Workaround

Activate the sleep mode in the mode register and then perform an AD conversion.

13.2.3 SPI

1. SPI Bad Serial Clock Generation on 2nd chip_select when SCBR = 1, CPOL=1 and NCPHA=0

When multiple CS are in use, if one of the baudrate equals to 1 and one of the others doesn't equal to 1, and CPOL=1 and CPHA=0, then an additional pulse will be generated on SCK.

Fix/workaround

When multiple CS are in use, if one of the baudrate equals 1, the other must also equal 1 if CPOL=1 and CPHA=0.

2. SPI Disable does not work in Slave mode

Fix/workaround

Read the last received data then perform a Software reset.

13.2.4 TWI

1. TWIM Version Register is zero

TWIM Version Register (VR) is zero instead of 0x100.

Fix/Workaround

None.

14. Datasheet Revision History

Please note that the referring page numbers in this section are referred to this document. The referring revision in this section are referring to the document revision.

14.1 Rev. A – 03/09

1. Initial revision.

Table of Contents

	Features	1
1	Description	3
2	Blockdiagram	4
	2.1 Processor and Architecture	5
3	Signals Description	6
4	Package and Pinout	11
	4.1 Package	11
	4.2 Peripheral Multiplexing on I/O lines	13
	4.3 Signal Descriptions	17
	4.4 Power Considerations	22
5	Power Considerations	23
	5.1 Power Supplies	23
	5.2 Voltage Regulator	23
6	I/O Line Considerations	24
	6.1 JTAG Pins	24
	6.2 RESET_N Pin	24
	6.3 TWI Pins	24
	6.4 GPIO Pins	24
7	Memories	25
	7.1 Embedded Memories	25
	7.2 Physical Memory Map	25
	7.3 Peripheral Address Map	26
	7.4 CPU Local Bus Mapping	28
8	Peripherals	29
	8.1 Clock Connections	29
	8.2 Peripheral Multiplexing on I/O lines	29
	8.3 Oscillator Pinout	32
	8.4 Peripheral overview	34
9	Boot Sequence	43
	9.1 Starting of Clocks	43
	9.2 Fetching of Initial Instructions	43

10	<i>Electrical Characteristics</i>	44
10.1	Absolute Maximum Ratings*	44
10.2	DC Characteristics	44
10.3	Regulator characteristics	46
10.4	Power Consumption	46
10.5	Clock Characteristics	48
10.6	Crystal Oscillator Characteristis	49
10.7	ADC Characteristics	51
10.8	USB Transceiver Characteristics	52
10.9	EBI Timings	53
10.10	JTAG Timings	59
10.11	SPI Characteristics	60
10.12	MACB Characteristics	62
10.13	Flash Characteristics	64
11	<i>Mechanical Characteristics</i>	65
11.1	Thermal Considerations	65
11.2	Package Drawings	66
11.3	Soldering Profile	68
12	<i>Ordering Information</i>	69
13	<i>Errata</i>	70
13.1	Rev. E	70
13.2	Rev. D	70
14	<i>Datasheet Revision History</i>	72
14.1	Rev. A – 03/09	72
	<i>Table of Contents</i>	<i>i</i>



Headquarters

Atmel Corporation
2325 Orchard Parkway
San Jose, CA 95131
USA
Tel: 1(408) 441-0311
Fax: 1(408) 487-2600

International

Atmel Asia
Unit 1-5 & 16, 19/F
BEA Tower, Millennium City 5
418 Kwun Tong Road
Kwun Tong, Kowloon
Hong Kong
Tel: (852) 2245-6100
Fax: (852) 2722-1369

Atmel Europe
Le Krebs
8, Rue Jean-Pierre Timbaud
BP 309
78054 Saint-Quentin-en-
Yvelines Cedex
France
Tel: (33) 1-30-60-70-00
Fax: (33) 1-30-60-71-11

Atmel Japan
9F, Tonetsu Shinkawa Bldg.
1-24-8 Shinkawa
Chuo-ku, Tokyo 104-0033
Japan
Tel: (81) 3-3523-3551
Fax: (81) 3-3523-7581

Product Contact

Web Site
www.atmel.com

Technical Support
avr32@atmel.com

Sales Contact
www.atmel.com/contacts

Literature Requests
www.atmel.com/literature

Disclaimer: The information in this document is provided in connection with Atmel products. No license, express or implied, by estoppel or otherwise, to any intellectual property right is granted by this document or in connection with the sale of Atmel products. **EXCEPT AS SET FORTH IN ATMEL'S TERMS AND CONDITIONS OF SALE LOCATED ON ATMEL'S WEB SITE, ATMEL ASSUMES NO LIABILITY WHATSOEVER AND DISCLAIMS ANY EXPRESS, IMPLIED OR STATUTORY WARRANTY RELATING TO ITS PRODUCTS INCLUDING, BUT NOT LIMITED TO, THE IMPLIED WARRANTY OF MERCHANTABILITY, FITNESS FOR A PARTICULAR PURPOSE, OR NON-INFRINGEMENT. IN NO EVENT SHALL ATMEL BE LIABLE FOR ANY DIRECT, INDIRECT, CONSEQUENTIAL, PUNITIVE, SPECIAL OR INCIDENTAL DAMAGES (INCLUDING, WITHOUT LIMITATION, DAMAGES FOR LOSS OF PROFITS, BUSINESS INTERRUPTION, OR LOSS OF INFORMATION) ARISING OUT OF THE USE OR INABILITY TO USE THIS DOCUMENT, EVEN IF ATMEL HAS BEEN ADVISED OF THE POSSIBILITY OF SUCH DAMAGES.** Atmel makes no representations or warranties with respect to the accuracy or completeness of the contents of this document and reserves the right to make changes to specifications and product descriptions at any time without notice. Atmel does not make any commitment to update the information contained herein. Unless specifically provided otherwise, Atmel products are not suitable for, and shall not be used in, automotive applications. Atmel's products are not intended, authorized, or warranted for use as components in applications intended to support or sustain life.

© 2009 Atmel Corporation. All rights reserved. Atmel®, logo and combinations thereof, AVR® and others are registered trademarks or trademarks of Atmel Corporation or its subsidiaries. Other terms and product names may be trademarks of others.