

TOSHIBA Bipolar Linear Integrated Circuit Silicon Monolithic

TA7267BP

Full-Bridge Driver (H-Switch) for DC Motor (Driver for Switching between Forward and Reverse Rotation)

The TA7267BP is a Bridge Driver for brushed DC Motor Rotation control.

Forward Rotation, Reverse Rotation, Stop and Braking operations are available.

It's designed for Loading and Reel Motor driver for VCR and Tape Deck, and any other consumer and industrial applications.

TA7267BP have Operation Supply Voltage terminal and Motor Driving Supply Voltage terminal independently, therefore Servo control operation is applicable.

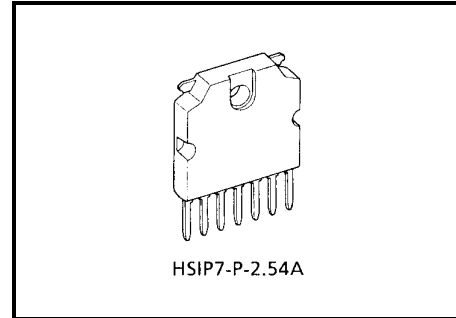

Weight: 2.15 g (typ.)

Features

- Output current up to 1.0 A (AVE.), and 3.0 A (PEAK)
- Four different modes (forward rotation, reverse rotation, stop, and brake) are supported.
- Built-in overcurrent protection and thermal shutdown circuit
- Operating voltage range: V_{CC} (opr.) = 6 to 18 V, V_S (opr.) = 0 to 18 V
- No malfunction occurs even if V_{CC} is higher than V_S or Vice versa.

The TA7267BP is Sn plated product including Pb.

The following conditions apply to solderability:

*Solderability

1. Use of Sn-37Pb solder bath
 - *solder bath temperature = 230°C
 - *dipping time = 5 seconds
 - *number of times = once
 - *use of R-type flux
2. Use of Sn-3.0Ag-0.5Cu solder bath
 - *solder bath temperature = 245°C
 - *dipping time = 5 seconds
 - *the number of times = once
 - *use of R-type flux

Block Diagram

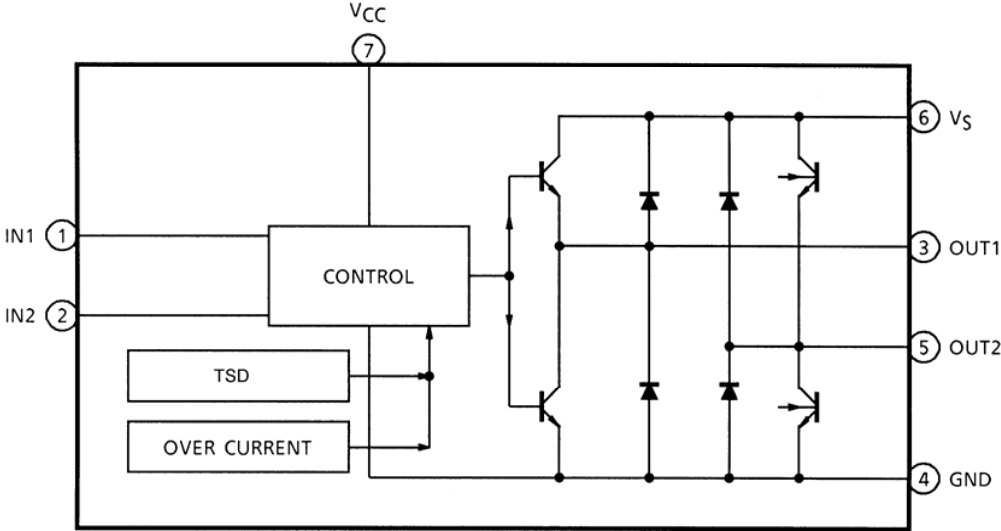

Pin Function

Pin No.	Symbol	Functional Description
1	IN1	Input terminal
2	IN2	Input terminal
3	OUT1	Output terminal
4	GND	GND terminal
5	OUT2	Output terminal
6	V _S	Voltage supply terminal
7	V _{CC}	Voltage supply terminal

Internal Circuit

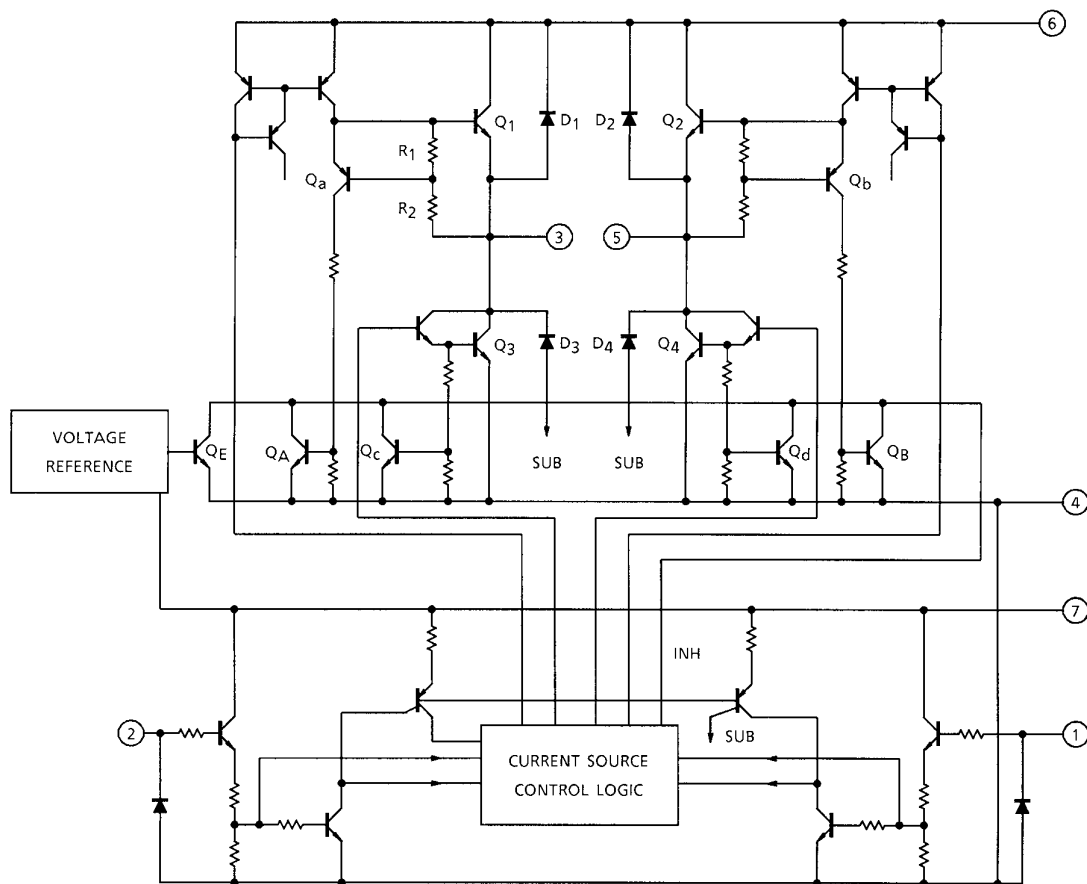

Function

IN1	IN2	OUT1	OUT2	Mode
1	1	L	L	Brake
0	1	L	H	CW/CCW
1	0	H	L	CCW/CW
0	0	High impedance		Stop

Absolute Maximum Ratings (Ta = 25°C)

Characteristics		Symbol	Rating	Unit
Supply voltage	PEAK	V _{CC} (max)	25	V
	OPERATE	V _{CC} (opr.)	18	
Output current	PEAK	I _O (PEAK)	3.0	A
	AVE.	I _O (AVE.)	1.0	
Power dissipation (Tc = 25°C)		P _D	12.5	W
Operating temperature		T _{opr}	-30 to 75	°C
Storage temperature		T _{stg}	-55 to 150	°C

Electrical Characteristics (unless otherwise specified, Ta = 25°C)

Characteristics		Symbol	Test circuit	Test condition	Min	Typ.	Max	Unit
Supply current		I _{CC1}	—	V _{CC} = 18 V, Output OFF Stop mode	—	1.8	3.5	mA
		I _{CC2}		V _{CC} = 18 V, Output OFF CW/CCW mode	—	8.3	12	
		I _{CC3}		V _{CC} = 18 V, Brake mode	—	8.5	13	
Saturation voltage		Upper	—	V _{CC} = 18 V, I _O = 0.1 A	—	—	1.1	V
		Lower			—	—	1.0	
		Upper		V _{CC} = 18 V, I _O = 1.0 A	—	1.2	1.5	
		Lower			—	1.05	1.4	
Output transistor leakage current		Upper	—	V _S = 25 V	—	—	50	μA
		Lower			—	—	50	
Input voltage 1, 2		V _{IN} (H)	—	T _j = 25°C, pin (1) and pin (2)	3.0	—	—	V
		V _{IN} (L)			—	—	0.8	
Input current 1, 2		I _{IN1, 2}	—	T _j = 25°C, pin (1) and pin (2)	—	1	30	μA
Diode forward voltage		V _F U	—	I _F = 1 A	—	2.0	—	V
		V _F L			—	1.3	—	
Limiting current		I _{SC}	—	—	—	2.5	—	A

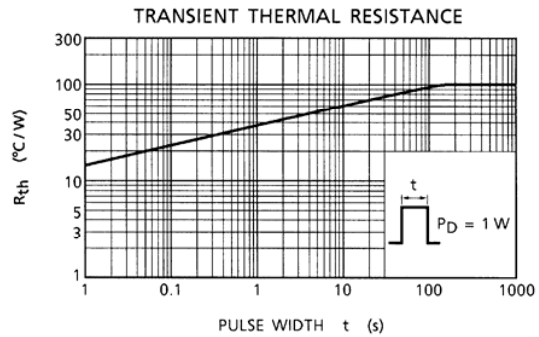
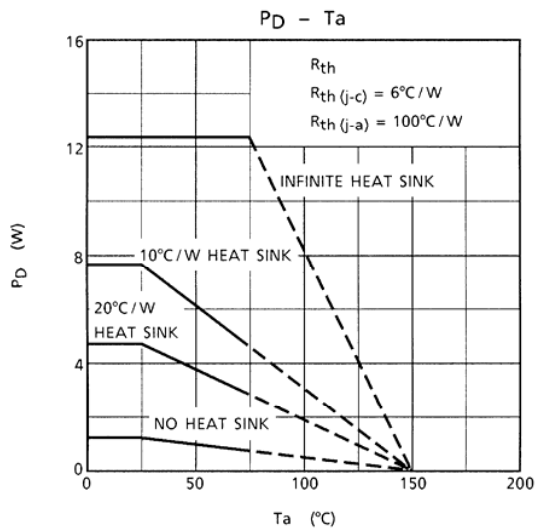

Test Circuit

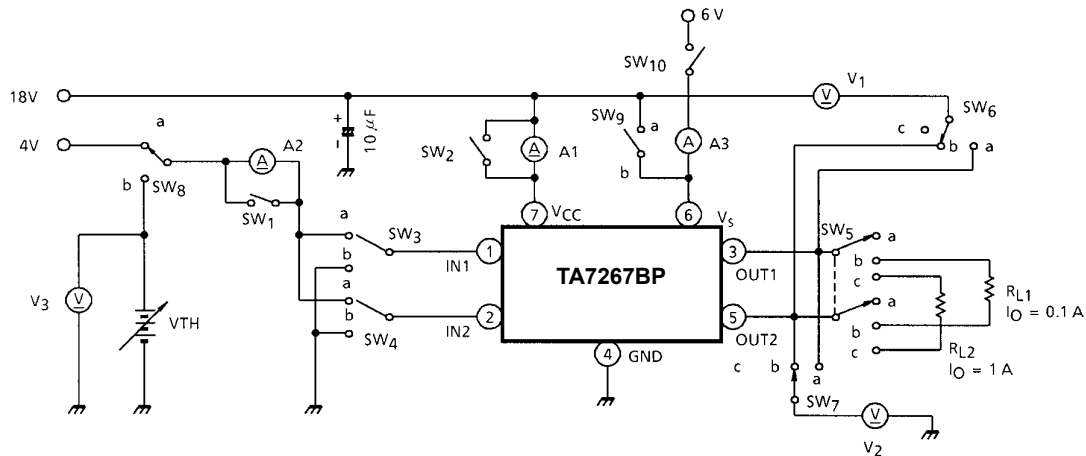

Test Method

Charac- Teristics	SW ₁	SW ₂	SW ₃	SW ₄	SW ₅	SW ₆	SW ₇	SW ₈	SW ₉	Test Meter
I _{CC1}	CLOSE	OPEN	b	b	a	c	c	a	a	A1 Use
I _{CC2}	CLOSE	OPEN	a	b	a	c	c	a	a	
I _{CC2}	CLOSE	OPEN	b	a	a	c	c	a	a	
I _{CC3}	CLOSE	OPEN	a	a	a	c	c	a	a	
V _{S1 U}	CLOSE	CLOSE	b	a	b	a	c	a	a	V ₁ Use, I _O = 0.1 A
V _{S1 U}	CLOSE	CLOSE	a	b	b	b	c	a	a	V ₂ Use, I _O = 0.1 A
V _{S1 L}	CLOSE	CLOSE	b	a	b	c	b	a	a	
V _{S1 L}	CLOSE	CLOSE	a	b	b	c	a	a	a	
V _{S2 U}	CLOSE	CLOSE	b	a	c	a	c	a	a	V ₁ Use, I _O = 1 A
V _{S2 U}	CLOSE	CLOSE	a	b	c	b	c	a	a	
V _{S2 L}	CLOSE	CLOSE	b	a	c	c	b	a	a	V ₂ Use, I _O = 1 A
V _{S2 L}	CLOSE	CLOSE	a	b	c	c	a	a	a	
V _{TH1}	CLOSE	CLOSE	a	b	b	c	c	b	a	V ₃ Use function check
V _{TH2}	CLOSE	CLOSE	b	a	b	c	c	b	a	
I _{SC}	CLOSE	CLOSE	a	b	b	c	c	a	b	A3 Use, SW ₁₀ = close
I _{IN1}	OPEN	CLOSE	a	b	b	c	c	a	a	A2 Use
I _{IN2}	OPEN	CLOSE	b	a	b	c	c	a	a	

Notes When Using The TA7267BP

The full bridge driver, TA7267BP, is an IC specifically developed to control rotation switching in brush motors. This IC has been carefully designed and strengthened to withstand counter-electromotive force or start up rush current, which are problems in driving brush motors.

However, as with other power ICs, application circuits must be designed not to apply surge voltage or excess current that exceeds the standard values.

In addition, when designing PCBs, make sure the wiring pattern does not cause oscillation, which can result in equipment malfunction or destruction of the IC.

The following are notes on TA7267BP use. These should be reflected at the design stage.

1. Maximum voltage and current

The maximum supply voltage (pins (6) and (7)) for TA7267BP is 25 V.

Operating supply voltage is in the range of 6 ~ 18 V. No voltage exceeding this range should be applied to pins (6) or (7).

The maximum current is 1.0 A (AVE.) or 3.0 A (PEAK). The circuit should be designed so that rush current at startup does not exceed peak current, and average current at steady operation does not exceed 1.0 A.

2. External diodes

As the block diagram shows, TA7267BP has internal diodes. The lower two diodes, which are the IC's internal parasitic diodes, have a relatively large capacitance. However, when a motor with a large reactance such as a core motor is driven, the upper two diodes may be damaged by the motor's counter-electromotive force.

In such a case, connect external diodes in parallel.

The lower diodes should not be subjected to high current. Therefore, in such cases as brake operation, external diodes should be connected.

3. PCB design

The following points concern the TA7267BP pattern design around the power supply line (pins (6) and (7)) and the pattern design of the GND (pin (4)).

- a. Ensure that the bypass capacitor between pin (6), pin (7), and GND does not share impedance with other lines.
- b. The GND line should not be shared by other circuits.
- c. The capacitance of the bypass capacitor should be as large as possible.

4. Oscillation remedies

To prevent noise from sparks when using brush motors, a capacitor may be connected between both pins. When using TA7267BP, the capacitor is connected between output pins (3) and (5). This may cause oscillation.

Therefore, avoid connecting the capacitor where possible. If connection is necessary to overcome noise, connect resistors in series as shown in the technical data.

The values for the capacitor and resistors must be determined according to the motor. However, recommended values are about 0.1 μ F and 33 Ω .

Application Note

(1) Input circuit

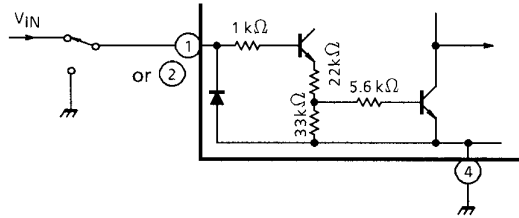

Figure 1

Input circuit is shown in Figure1. It's a "High Active" type.

If a voltage above specified $V_{IN(H)}$ value fed into input terminal that means "Logic 1", and the voltage less than $V_{IN(L)}$ or connect to GND means "Logic 0".

And the circuit have a hysteresis for stable operation. (See Figure 2)

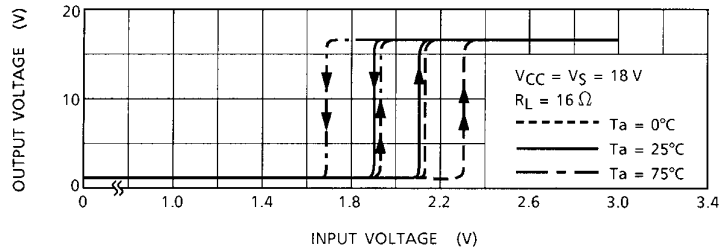

Figure 2 $V_{IN} - V_{OUT}$ characteristics

(2) Basic application circuit

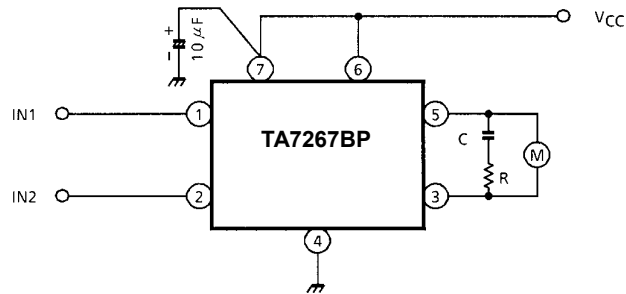

Figure 3

Note 1: Figure 3 shows the basic application circuit.

Optimum values of the C, R depend on the inherent constant of a motor and parasitic C, R values around the circuit.

Note 2: Utmost care is necessary in the design of the output, V_{CC} , V_M , and GND lines since the IC may be destroyed by short-circuiting between outputs, air contamination faults, or faults due to improper grounding, or by short-circuiting between contiguous pins.

Note 3: Be careful when switching the input because rush current may occur.

When switching, stop mode should be entered or current limitation resistor R should be inserted.

Note 4: The IC functions cannot be guaranteed when turning power on or off.

Before using the IC for application, check that there are no problems.

(3) Additional diode

- i) If the braking operation is so loose, connect a additional diode between each output to GND. (See Figure 4)
- ii) If the back electromotive pulse generated in output coil is so strong. Internally connected back electromotive suppression diode may be damaged by this pulse. In such a case connect a additional diode between each output to V_{CC} . (See Figure 5)

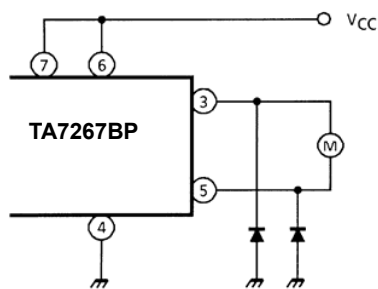

Figure 4

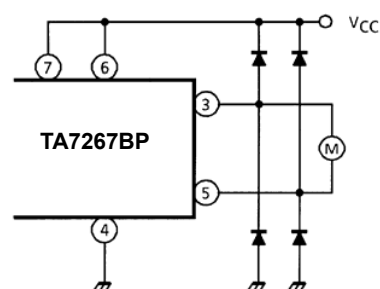
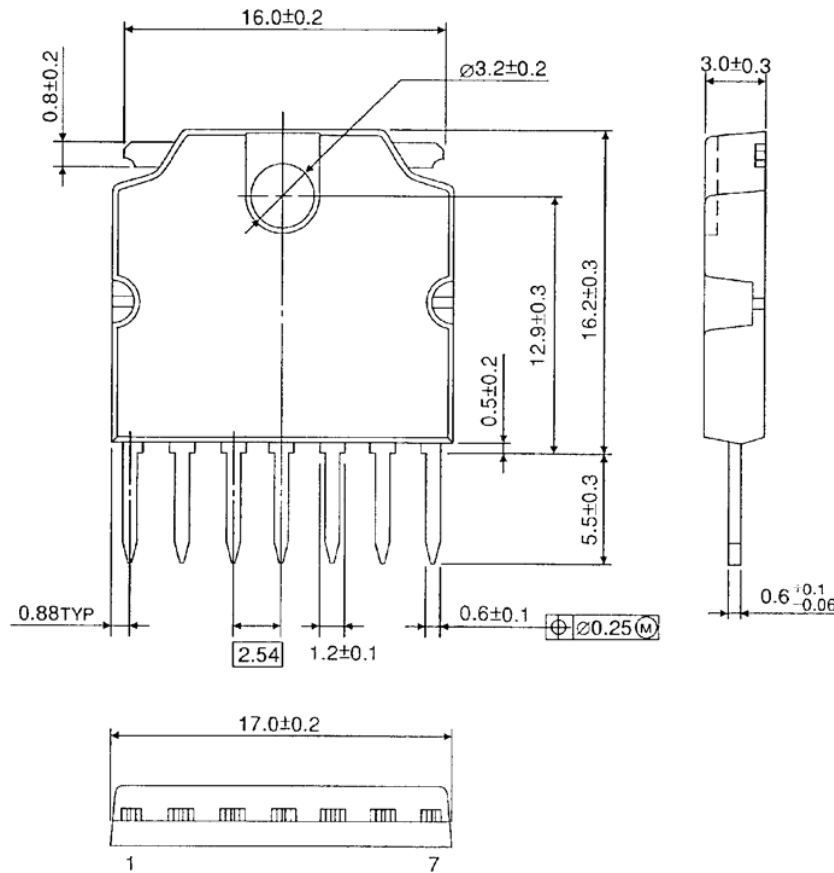

Figure 5

Package Dimensions

HSIP7-P-2.54A

Unit : mm



Weight: 2.15 g (typ.)

Notes on Contents**1. Block Diagrams**

Some of the functional blocks, circuits, or constants in the block diagram may be omitted or simplified for explanatory purposes.

2. Equivalent Circuits

The equivalent circuit diagrams may be simplified or some parts of them may be omitted for explanatory purposes.

3. Timing Charts

Timing charts may be simplified for explanatory purposes.

4. Application Circuits

The application circuits shown in this document are provided for reference purposes only. Thorough evaluation is required, especially at the mass production design stage.

Toshiba does not grant any license to any industrial property rights by providing these examples of application circuits.

5. Test Circuits

Components in the test circuits are used only to obtain and confirm the device characteristics. These components and circuits are not guaranteed to prevent malfunction or failure from occurring in the application equipment.

IC Usage Considerations**Notes on handling of ICs**

- [1] The absolute maximum ratings of a semiconductor device are a set of ratings that must not be exceeded, even for a moment. Do not exceed any of these ratings.
Exceeding the rating(s) may cause the device breakdown, damage or deterioration, and may result injury by explosion or combustion.
- [2] Use an appropriate power supply fuse to ensure that a large current does not continuously flow in case of over current and/or IC failure. The IC will fully break down when used under conditions that exceed its absolute maximum ratings, when the wiring is routed improperly or when an abnormal pulse noise occurs from the wiring or load, causing a large current to continuously flow and the breakdown can lead smoke or ignition. To minimize the effects of the flow of a large current in case of breakdown, appropriate settings, such as fuse capacity, fusing time and insertion circuit location, are required.
- [3] If your design includes an inductive load such as a motor coil, incorporate a protection circuit into the design to prevent device malfunction or breakdown caused by the current resulting from the inrush current at power ON or the negative current resulting from the back electromotive force at power OFF. IC breakdown may cause injury, smoke or ignition.
Use a stable power supply with ICs with built-in protection functions. If the power supply is unstable, the protection function may not operate, causing IC breakdown. IC breakdown may cause injury, smoke or ignition.
- [4] Do not insert devices in the wrong orientation or incorrectly.
Make sure that the positive and negative terminals of power supplies are connected properly. Otherwise, the current or power consumption may exceed the absolute maximum rating, and exceeding the rating(s) may cause the device breakdown, damage or deterioration, and may result injury by explosion or combustion.
In addition, do not use any device that is applied the current with inserting in the wrong orientation or incorrectly even just one time.

Points to remember on handling of ICs**(1) Over current Protection Circuit**

Over current protection circuits (referred to as current limiter circuits) do not necessarily protect ICs under all circumstances. If the Over current protection circuits operate against the over current, clear the over current status immediately.

Depending on the method of use and usage conditions, such as exceeding absolute maximum ratings can cause the over current protection circuit to not operate properly or IC breakdown before operation. In addition, depending on the method of use and usage conditions, if over current continues to flow for a long time after operation, the IC may generate heat resulting in breakdown.

(2) Thermal Shutdown Circuit

Thermal shutdown circuits do not necessarily protect ICs under all circumstances. If the thermal shutdown circuits operate against the over temperature, clear the heat generation status immediately.

Depending on the method of use and usage conditions, such as exceeding absolute maximum ratings can cause the thermal shutdown circuit to not operate properly or IC breakdown before operation.

(3) Heat Radiation Design

In using an IC with large current flow such as power amp, regulator or driver, please design the device so that heat is appropriately radiated, not to exceed the specified junction temperature (T_j) at any time and condition. These ICs generate heat even during normal use. An inadequate IC heat radiation design can lead to decrease in IC life, deterioration of IC characteristics or IC breakdown. In addition, please design the device taking into consideration the effect of IC heat radiation with peripheral components.

(4) Back-EMF

When a motor rotates in the reverse direction, stops or slows down abruptly, a current flow back to the motor's power supply due to the effect of back-EMF. If the current sink capability of the power supply is small, the device's motor power supply and output pins might be exposed to conditions beyond maximum ratings. To avoid this problem, take the effect of back-EMF into consideration in system design.

RESTRICTIONS ON PRODUCT USE

060925EBA

- The information contained herein is subject to change without notice. 021023_D
- TOSHIBA is continually working to improve the quality and reliability of its products. Nevertheless, semiconductor devices in general can malfunction or fail due to their inherent electrical sensitivity and vulnerability to physical stress. It is the responsibility of the buyer, when utilizing TOSHIBA products, to comply with the standards of safety in making a safe design for the entire system, and to avoid situations in which a malfunction or failure of such TOSHIBA products could cause loss of human life, bodily injury or damage to property.
In developing your designs, please ensure that TOSHIBA products are used within specified operating ranges as set forth in the most recent TOSHIBA products specifications. Also, please keep in mind the precautions and conditions set forth in the "Handling Guide for Semiconductor Devices," or "TOSHIBA Semiconductor Reliability Handbook" etc. 021023_A
- The TOSHIBA products listed in this document are intended for usage in general electronics applications (computer, personal equipment, office equipment, measuring equipment, industrial robotics, domestic appliances, etc.). These TOSHIBA products are neither intended nor warranted for usage in equipment that requires extraordinarily high quality and/or reliability or a malfunction or failure of which may cause loss of human life or bodily injury ("Unintended Usage"). Unintended Usage include atomic energy control instruments, airplane or spaceship instruments, transportation instruments, traffic signal instruments, combustion control instruments, medical instruments, all types of safety devices, etc. Unintended Usage of TOSHIBA products listed in this document shall be made at the customer's own risk. 021023_B
- The products described in this document shall not be used or embedded to any downstream products of which manufacture, use and/or sale are prohibited under any applicable laws and regulations. 060106_Q
- The information contained herein is presented only as a guide for the applications of our products. No responsibility is assumed by TOSHIBA for any infringements of patents or other rights of the third parties which may result from its use. No license is granted by implication or otherwise under any patent or patent rights of TOSHIBA or others. 021023_C
- The products described in this document are subject to foreign exchange and foreign trade control laws. 060925_E