

CMPD1001  
 CMPD1001A  
 CMPD1001S

**SURFACE MOUNT  
 HIGH CURRENT  
 SILICON SWITCHING DIODE**

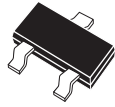

**SOT-23 CASE**

**Central**<sup>TM</sup>  
**Semiconductor Corp.**

**DESCRIPTION:**

The Central Semiconductor CMPD1001 series types are silicon switching diodes manufactured by the epitaxial planar process, designed for applications requiring high current capability.

The following configurations are available:

CMPD1001  
 CMPD1001A  
 CMPD1001S

SINGLE  
 DUAL, COMMON ANODE  
 DUAL, IN SERIES

**MARKING CODE: L20**  
**MARKING CODE: L22**  
**MARKING CODE: L21**

**MAXIMUM RATINGS:** ( $T_A=25^\circ\text{C}$ )

	SYMBOL		UNITS
Continuous Reverse Voltage	$V_R$	90	V
Continuous Forward Current	$I_F$	250	mA
Peak Repetitive Forward Current	$I_{FRM}$	600	mA
Peak Repetitive Reverse Current	$I_{RRM}$	600	mA
Forward Surge Current, $t_p=1.0 \mu\text{s}$	$I_{FSM}$	6.0	A
Forward Surge Current, $t_p=1.0 \text{s}$	$I_{FSM}$	1.0	A
Power Dissipation	$P_D$	350	mW
Operating and Storage			
Junction Temperature	$T_J, T_{stg}$	-65 to +150	$^\circ\text{C}$
Thermal Resistance	$\theta_{JA}$	357	$^\circ\text{C/W}$

**ELECTRICAL CHARACTERISTICS PER DIODE:** ( $T_A=25^\circ\text{C}$  unless otherwise noted)

SYMBOL	TEST CONDITIONS	MIN	MAX	UNITS
$BV_R$	$I_R=100\mu\text{A}$	90		V
$I_R$	$V_R=90\text{V}$		100	nA
$I_R$	$V_R=90\text{V}, T_A=150^\circ\text{C}$		100	$\mu\text{A}$
$V_F$	$I_F=10\text{mA}$		0.75	V
$V_F$	$I_F=50\text{mA}$		0.84	V
$V_F$	$I_F=100\text{mA}$		0.90	V
$V_F$	$I_F=200\text{mA}$		1.00	V
$V_F$	$I_F=400\text{mA}$		1.25	V
$C_T$	$V_R=0\text{V}, f=1.0 \text{MHz}$		35	pF
$t_{rr}$	$I_R=I_F=30\text{mA}, \text{Rec. to } 3.0\text{mA}, R_L=100\Omega$		50	ns

R5 (6-August 2003)

**SOT-23 CASE - MECHANICAL OUTLINE**

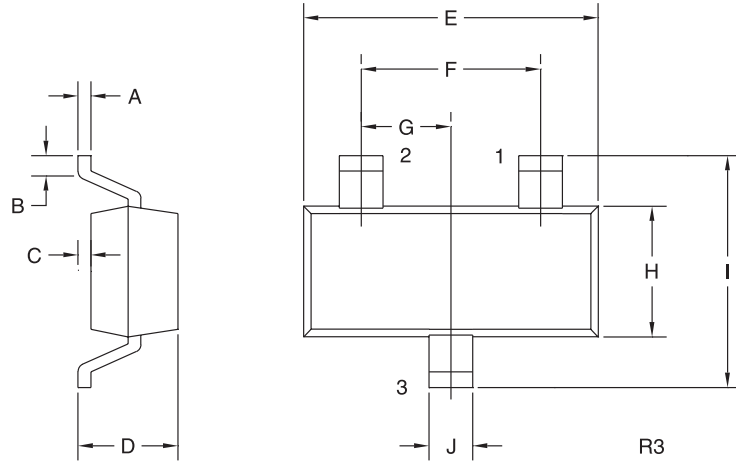

SYMBOL	INCHES		MILLIMETERS	
	MIN	MAX	MIN	MAX
A	0.003	0.007	0.08	0.18
B	0.006	-	0.15	-
C	-	0.005	-	0.13
D	0.035	0.043	0.89	1.09
E	0.110	0.120	2.80	3.05
F	0.075		1.90	
G	0.037		0.95	
H	0.047	0.055	1.19	1.40
I	0.083	0.098	2.10	2.49
J	0.014	0.020	0.35	0.50

SOT-23 (REV: R3)

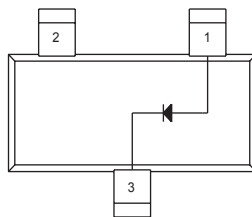

**LEAD CODE:**  
**CMPD1001**  
1) Anode  
2) No Connection  
3) Cathode  
**MARKING CODE: L20**

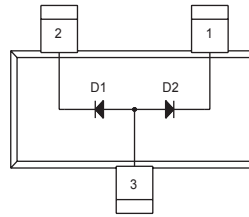

**LEAD CODE:**  
**CMPD1001A**  
1) Cathode D2  
2) Cathode D1  
3) Anode D1, Anode D2  
**MARKING CODE: L22**

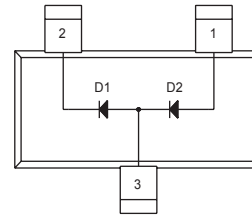

**LEAD CODE:**  
**CMPD1001S**  
1) Anode D2  
2) Cathode D1  
3) Anode D1, Cathode D2  
**MARKING CODE: L21**

R5 (6-August 2003)