

240 Amp Schottky Rectifier HS24515

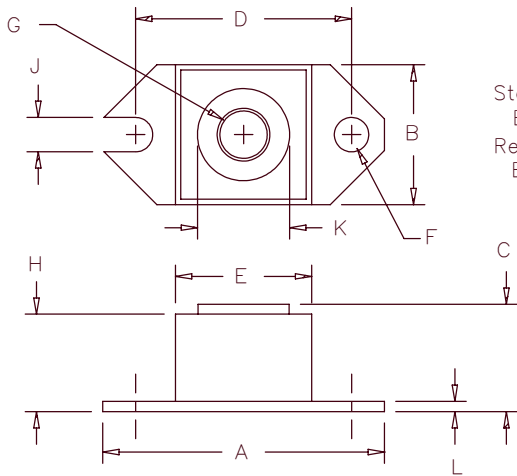

Std. Polarity
Base is cathode
Rev. Polarity
Base is anode

Dim.	Inches		Millimeter		Notes
	Minimum	Maximum	Minimum	Maximum	
A	1.52	1.56	38.86	39.62	
B	.725	.775	18.42	19.69	
C	.605	.625	15.37	15.88	
D	1.177	1.197	29.90	30.41	
E	.745	.755	18.92	19.18	Sq.
F	.152	.162	3.86	4.11	Dia.
G		1/4-20	UNC-2B		
H	.540	.580	13.72	14.73	
J	.152	.162	3.86	4.11	
K	.495	.505	12.57	12.83	Dia.
L	.120	.130	3.05	3.30	

Microsemi Catalog Number	Industry Part Number	Working Peak Reverse Voltage	Repetitive Peak Reverse Voltage
HS24515*	245NQ015	15V	15V

*Add Suffix R for Reverse Polarity

- Schottky Barrier Rectifier
- 0.28V Vf@240A, 100°C
- Optimized for OR'ing applications
- Guard Ring Reverse Protection
- 125°C Operation (Vr<5V)
- ROHS Compliant

Electrical Characteristics

Average forward current	I _{F(AV)} 240 Amps	T _C = 78°C, V _r = 5V
Average forward current	I _{F(AV)} 240 Amps	T _C = 69°C, V _r = 15V
Maximum surge current	I _{FSM} 3500 Amps	8.3ms, half sine, T _J = 125°C
Maximum repetitive reverse current	I _{R(OV)} 2 Amps	f = 1 KHZ, 25°C, 1μs square wave
Max peak forward voltage	V _{FM} 0.37 Volts	I _{FM} = 240A: T _J = 25°C*
Max peak forward voltage	V _{FM} 0.30 Volts	I _{FM} = 240A: T _J = 100°C*
Max peak reverse current	I _{RM} 4000 mA	V _R = 5V, T _J = 100°C*
Max peak reverse current	I _{RM} 6500 mA	V _{RRM} , T _J = 100°C*
Max peak reverse current	I _{RM} 75mA	V _R = 5V, T _J = 25°C
Max peak reverse current	R _M 150mA	V _{RRM} , T _J = 25°C
Typical junction capacitance	C _J 21,700pF	V _R = 5.0V, T _C = 25°C

*Pulse test: Pulse width 300μsec, Duty cycle 2%

Thermal and Mechanical Characteristics

Storage temp range	T _{STG}	-55°C to 150°C
Operating junction temp range	T _J	-55°C to 125°C
Max thermal resistance	R _{θJC}	0.24°C/W Junction to case
Typical thermal resistance (greased)	R _{θCS}	0.12°C/W Case to sink
Terminal Torque		35-40 inch pounds
Mounting Base Torque		20-25 inch pounds
Weight		1.1 ounces (32 grams) typical

HS24515

Figure 1
Typical Forward Characteristics

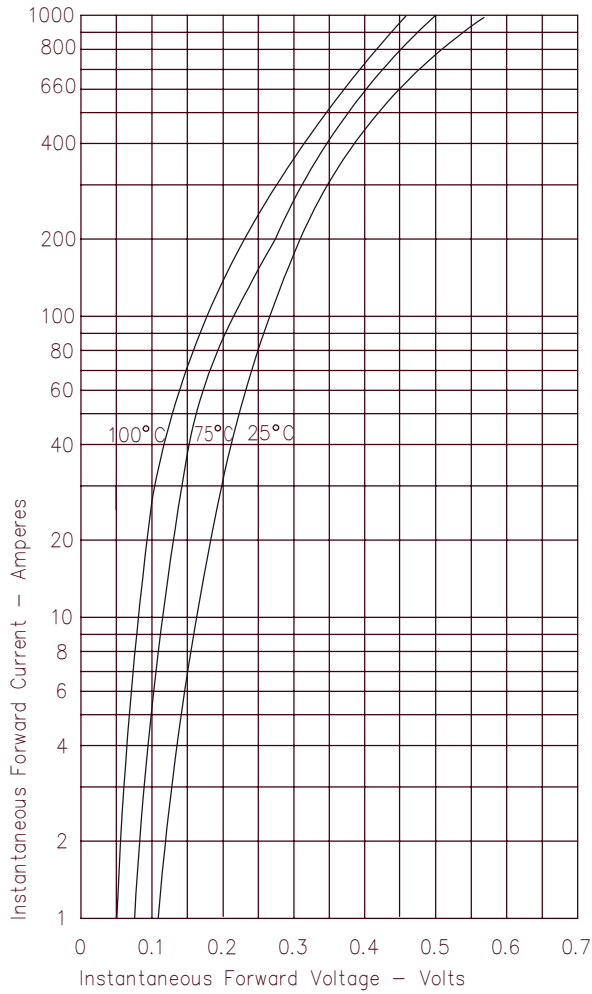

Figure 3
Typical Junction Capacitance

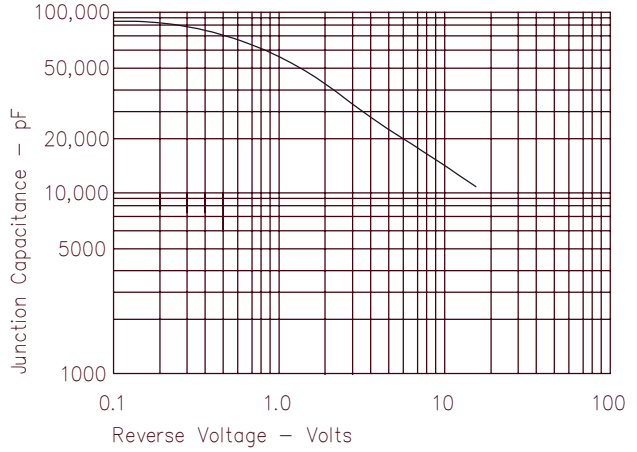

Figure 4
Forward Current Derating

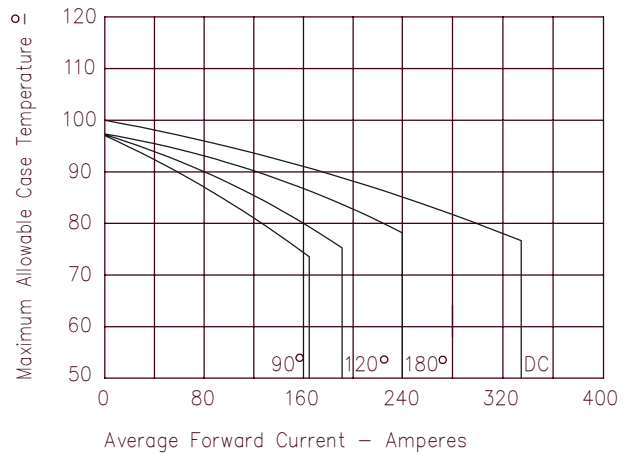

Figure 2
Typical Reverse Characteristics

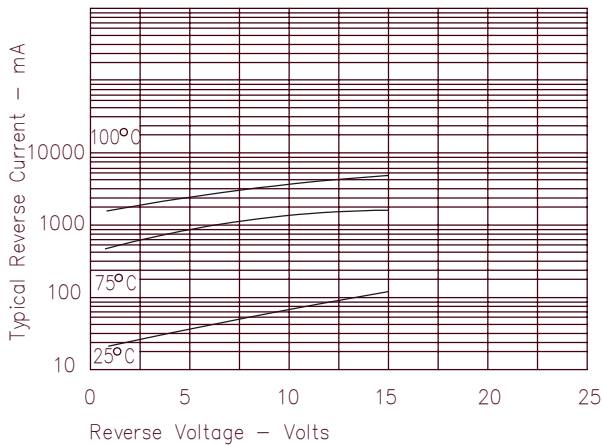

Figure 5
Maximum Forward Power Dissipation

