

**GLASS PASSIVATED SUPER FAST
 SILICON SURFACE MOUNT BRIDGE RECTIFIER**
VOLTAGE RANGE 50 to 400 Volts CURRENT 1.0 Ampere

FEATURES

- * Surge overloading rating - 50 amperes peak
- * Ideal for printed circuit board
- * Reliable low cost construction utilizing molded
- * Glass passivated device
- * Polarity symbols molded on body
- * Mounting position: Any
- * Weight: 1.0 gram

MECHANICAL DATA

- * Epoxy : Device has UL flammability classification 94V-0

MAXIMUM RATINGS AND ELECTRICAL CHARACTERISTICS

Ratings at 25 °C ambient temperature unless otherwise specified.
 Single phase, half wave, 60 Hz, resistive or inductive load.
 For capacitive load, derate current by 20%.

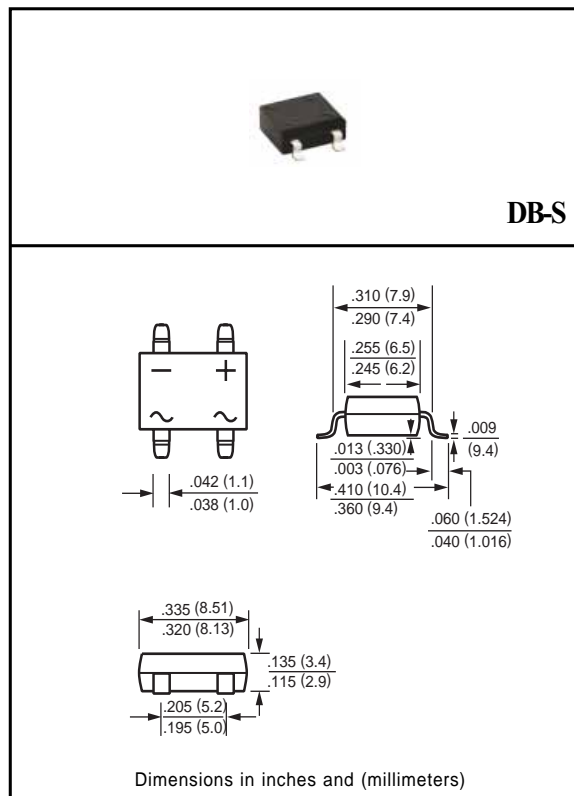

MAXIMUM RATINGS (At TA = 25°C unless otherwise noted)

RATINGS	SYMBOL	EDB101S	EDB102S	EDB103S	EDB104S	EDB105S	EDB106S	UNITS
Maximum Recurrent Peak Reverse Voltage	VRRM	50	100	150	200	300	400	Volts
Maximum RMS Volts	VRMS	35	70	105	140	210	280	Volts
Maximum DC Blocking Voltage	VDC	50	100	150	200	300	400	Volts
Maximum Average Forward Current at TA = 55°C	Io	1.0						Amps
Peak Forward Surge Current IFM (surge): 8.3 ms single half sine-wave superimposed on rated load (JEDEC method)	IFSM	30						Amps
Typical Junction Capacitance (Note 2)	CJ	15				10		pF
Operating and Storage Temperature Range	TJ, TSTG	-65 to + 150						°C

ELECTRICAL CHARACTERISTICS (At TA = 25°C unless otherwise noted)

CHARACTERISTICS	SYMBOL	EDB101S	EDB102S	EDB103S	EDB104S	EDB105S	EDB106S	UNITS
Maximum Forward Voltage at 1.0A DC	VF	1.0				1.25		Volts
Maximum DC Reverse Current at Rated DC Blocking Voltage	IR	@TA = 25°C						uAmps
		@TA =150°C						
Maximum Reverse Recovery Time (Note 1)	trr	50						nSec

NOTES : 1. Test Conditions: IF=0.5A, IR=-1.0A, IRR=-0.25A.
 2. Measured at 1 MHz and applied reverse voltage of 4.0 volts.

RATING AND CHARACTERISTIC CURVES (EDB101S THRU EDB106S)

FIG. 1 - TEST CIRCUIT DIAGRAM AND REVERSE RECOVERY TIME CHARACTERISTIC

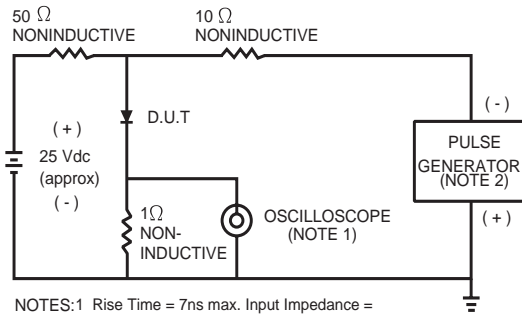

NOTES: 1 Rise Time = 7ns max. Input Impedance = 1 megohm. 22 pF.
2. Rise Time = 10ns max. Source Impedance = 50 ohms.

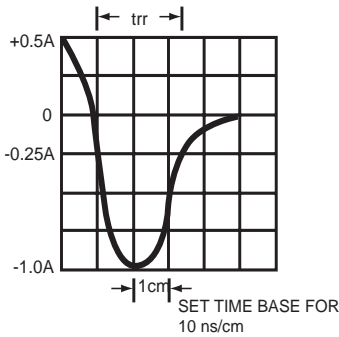

FIG. 2 - TYPICAL FORWARD CURRENT DERATING CURVE

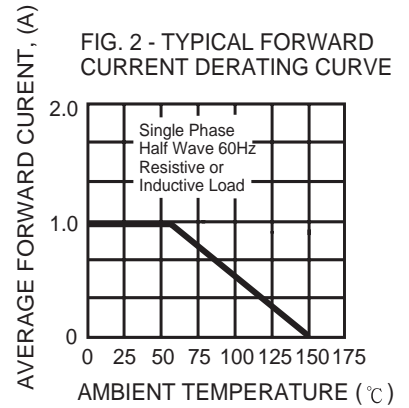

FIG. 3 - TYPICAL REVERSE CHARACTERISTICS

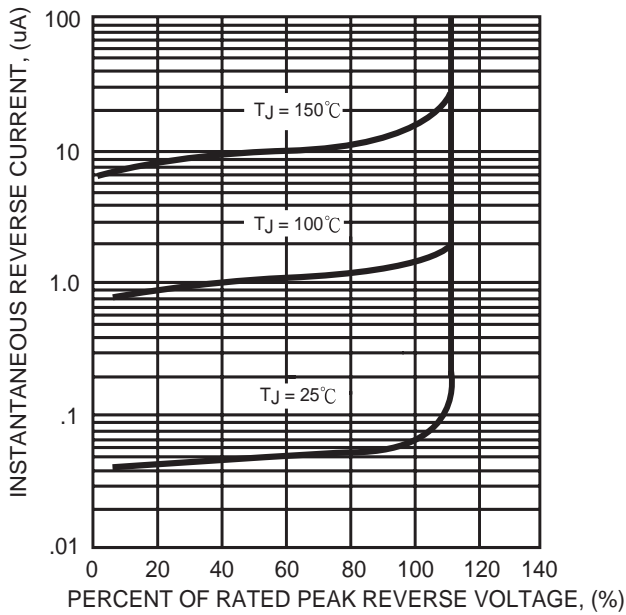

FIG. 4 - TYPICAL INSTANTANEOUS FORWARD CHARACTERISTICS

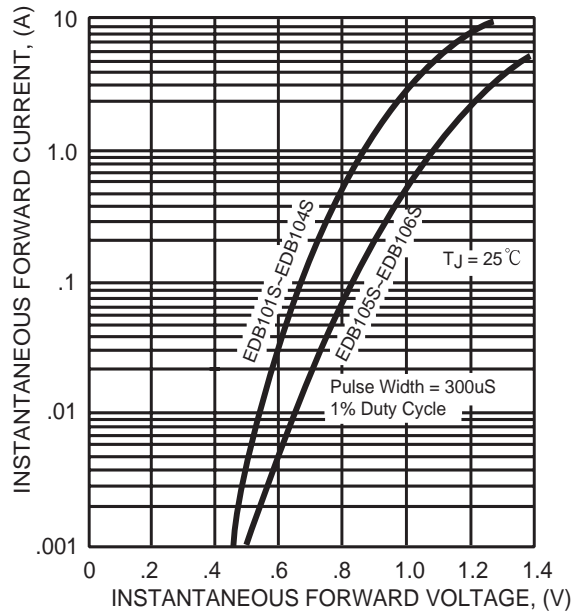

FIG. 5 - MAXIMUM NON-REPETITIVE FORWARD SURGE CURRENT

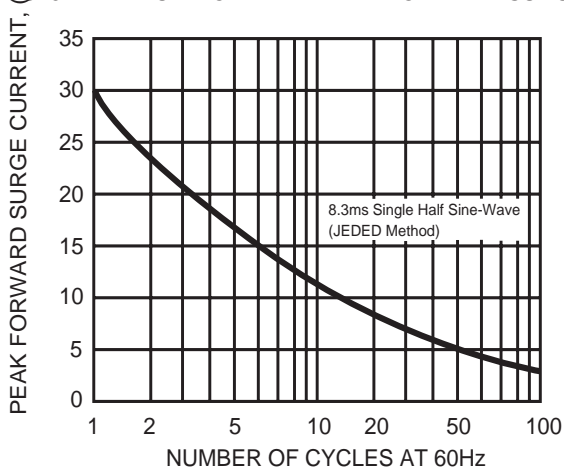

FIG. 6 - TYPICAL JUNCTION CAPACITANCE

