

JFET RF, VHF, UHF Amplifiers

2N3819-
434-759

N Channel

Junction FETs

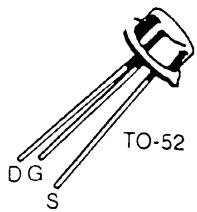

Device	BV _{GSS} (V) Min	V _p @ V _{DS} I _D				Re(Y _{fs}) (mmho) @ f		Re(Y _{os}) (μmho) @ f		C _{iss} (pF) Max	C _{rss} (pF) Max	NF (dB) @ R _g = 1k		Package
		(V)		(V)	(nA)	(MHz)		(MHz)				Max	(MHz)	
		Min	Max			Min	Max	Max	Max					
2N3819	25		8	15	2	1.6	100			8	4			TO-92(94)
2N4416	30	2.5	6	15	1	4	400	100	400	4	0.9	4	400	TO-72
PN4416	30	2.5	6	15	1	4	400	100	400	4	0.9	4	400	TO-92(92)
MMBF4416	30	2.5	6	15	1	4	400	100	400	4	0.9	4	400	TO-236*
2N5245	30	1	6	15	10	4	400	100	400	4.5	1.0	4	400	TO-92(97)
2N5246	30	0.5	4	15	10	2.5	400	100	400	4.5	1.0	4	400	TO-92(97)
2N5247	30	1.5	8	15	10	4	400	150	400	4.5	1.0	4	400	TO-92(97)
2N5397	25	1	6	10	1	5.5	450	400	450	5	1.2	3.5	450	TO-72
2N5484	25	0.3	3	15	10	2.5	100	75	100	5	1	3	100	TO-92(92)
MMBF5484	25	0.3	3	15	10	2.5	100	75	100	5	1	3	100	TO-236*
2N5485	25	0.5	4	15	10	3	400	100	400	5	1	4	400	TO-92(92)
MMBF5485	25	0.5	4	15	10	3	400	100	400	5	1	4	400	TO-236*
2N5486	25	2	6	15	10	3.5	400	100	400	5	1	4	400	TO-92(92)
MMBF5486	25	2	6	15	10	3.5	400	100	400	5	1	4	400	TO-236*
2N5949	30	3	7	15	100	3	100	150	100	6	2	5	100	TO-92(97)
2N5950	30	2.5	6	15	100	3	100	125	100	6	2	5	100	TO-92(97)
2N5951	30	2	5	15	100	3	100	100	100	6	2	5	100	TO-92(97)
2N5952	30	1.3	4.5	15	100	1	100	75	100	6	2	5	100	TO-92(97)
2N5953	30	0.8	3	15	100	1	100	50	100	6	2	5	100	TO-92(97)
J300	25	1	6	10	1	4.5	0.001	200	0.001	5.5	1.7			TO-92(92)
MMBFJ304	30	2	6	15	1	t4.2	400	t80	100					TO-236*
J304	30	2	6	15	1	t4.2	400	t80	100					TO-92(92)
J305	30	0.5	3	15	1	t3.0	400	t80	100					TO-92(92)
MMBFJ305	30	0.5	3	15	1	t3.0	400	t80	100					TO-236*
MMBFJ309	25	1	4	10	1	10	0.001	150	0.001	7.5	2.5			TO-236*
J309	25	1	4	10	1	10	0.001	150	0.001	7.5	2.5			TO-92(92)
MMBFJ310	25	2	6.5	10	1	8	0.001	150	0.001	7.5	2.5			TO-236*
J310	25	2	6.5	10	1	8	0.001	150	0.001	7.5	2.5			TO-92(92)
U309	25	1	4	10	1	10	0.001	150	100	5	2.5			TO-52
U310	25	2.5	6	10	1	10	0.001	150	100	5	2.5			TO-52

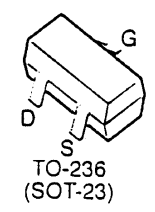
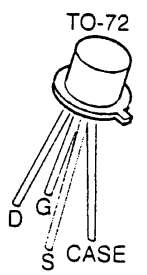
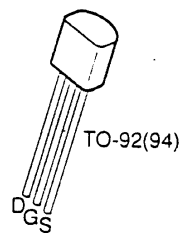
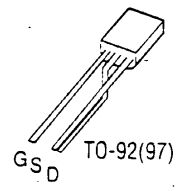
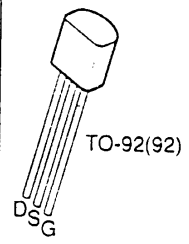

3

* TO-236AB is standard for all devices.
Please refer to Surface Mount section for TO-236 Device Marking.
t = typical value

TO-72 (23, 25, 28, 29)

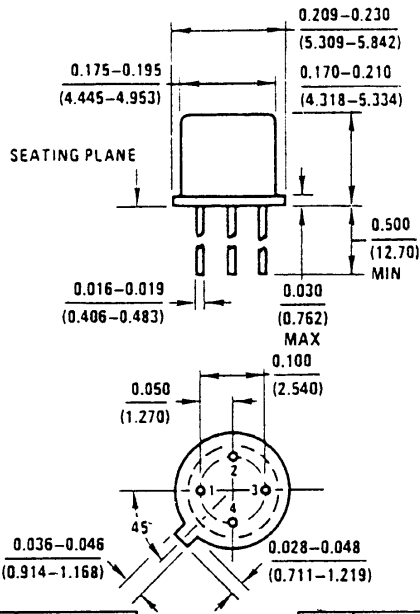

Pin	T (18)	FET N(25, 29)
1	E	S
2	B	D
3	C	G
4	GND	CASE

Pin	T (18)	FET P(23)
1	E	S
2	B	G
3	C	D
4	GND	CASE

TO-78 (24, 30)

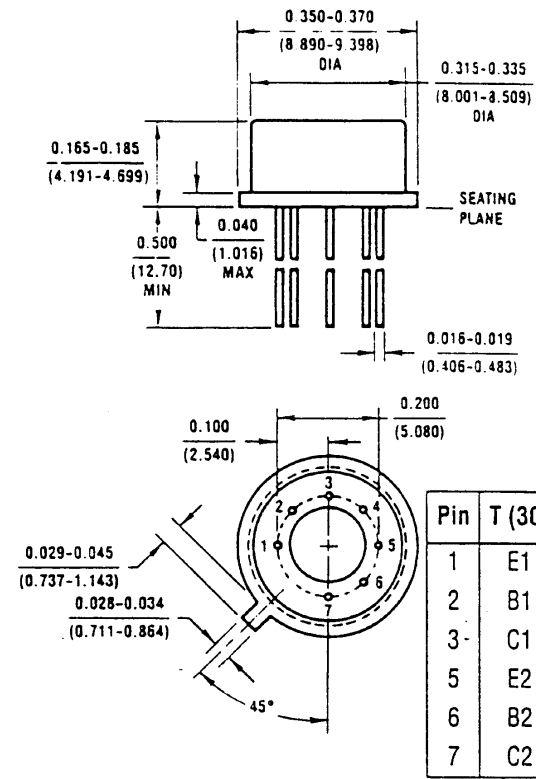

Pin	T (30)	FET(24)
1	E1	S1
2	B1	D1
3	C1	G1
5	E2	S2
6	B2	D2
7	C2	G2

TO-92 (92, 94, 96)

2N 3819.

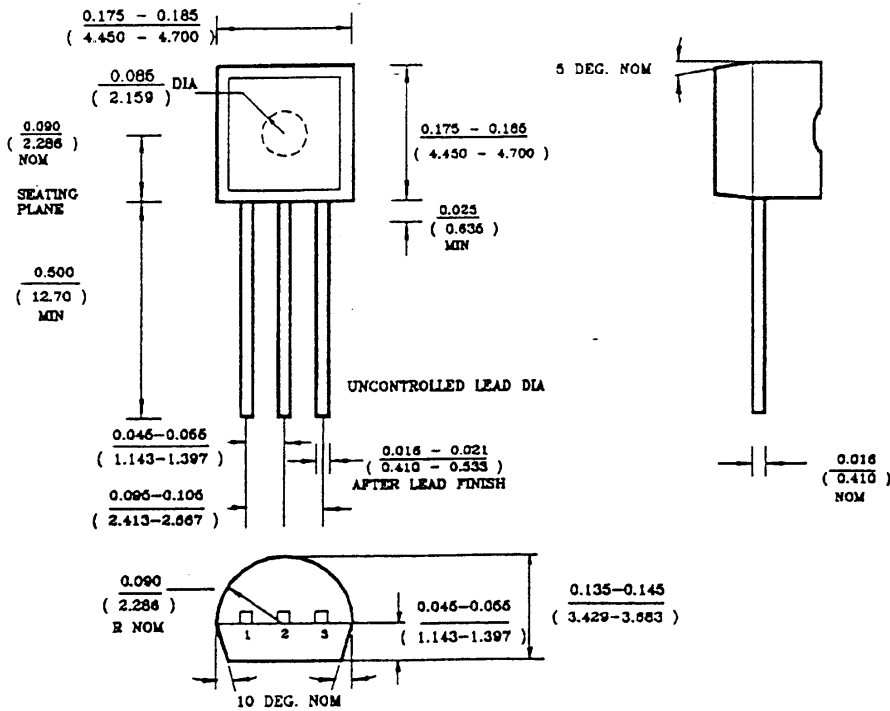

Pin	(96)	
	T	FET
1	C	G
2	E	D
3	B	S

Pin	(92) STD		
	T	FET	DMOS
1	C	G	S
2	B	S	G
3	E	D	D

Pin	(94)	
	T	FET
1	B	S
2	C	G
3	E	D