



ELECTRONICS, INC.
44 FARRAND STREET
BLOOMFIELD, NJ 07003
(973) 748-5089

NTE81 Silicon NPN Transistor Dual Differential Amp, General Purpose Switch

Absolute Maximum Ratings:

Collector–Emitter Voltage, V_{CEO}	30V
Collector–Base Voltage, V_{CBO}	60V
Emitter–Base Voltage, V_{EBO}	5V
Continuous Collector Current, I_C	500mA
Total Device Dissipation ($T_A = +25^\circ\text{C}$), P_D	
One Die	575mW
All Die Equal Power	625mW
Derate Above 25°C	
One Die	3.29mW/ $^\circ\text{C}$
All Die Equal Power	3.57mW/ $^\circ\text{C}$
Total Device Dissipation ($T_C = +25^\circ\text{C}$), P_D	
One Die	1.8W
All Die Equal Power	2.5W
Derate Above 25°C	
One Die	10.3mW/ $^\circ\text{C}$
All Die Equal Power	14.3mW/ $^\circ\text{C}$
Operating Junction Temperature Range, T_J	-65° to $+200^\circ\text{C}$
Storage Temperature Range, T_{stg}	-65° to $+200^\circ\text{C}$
Thermal Resistance, Junction–to–Case, $R_{\theta JC}$	
One Die	97 $^\circ\text{C}/\text{W}$
All Die Equal Power	70 $^\circ\text{C}/\text{W}$
Thermal Resistance, Junction–to–Ambient (Note 1), R_{thJA}	
One Die	304 $^\circ\text{C}/\text{W}$
All Die Equal Power	280 $^\circ\text{C}/\text{W}$
Coupling Factors	
Q1 – Q2	
Junction–to–Ambient	57%
Junction–to–Case	0%
Q1 – Q3 or Q1 – Q4	
Junction–to–Ambient	55%
Junction–to–Case	0%

Note 1. R_{thJA} is measured with the device soldered into a typical printed circuit board.

Electrical Characteristics: ($T_A = +25^\circ\text{C}$ unless otherwise specified)

Parameter	Symbol	Test Conditions	Min	Typ	Max	Unit
OFF Characteristics						
Collector–Emitter Breakdown Voltage	$V_{(BR)CEO}$	$I_C = 10\text{mA}, I_B = 0, \text{Note 2}$	30	–	–	V
Collector–Base Breakdown Voltage	$V_{(BR)CBO}$	$I_C = 10\mu\text{A}, I_E = 0$	60	–	–	V
Emitter–Base Breakdown Voltage	$V_{(BR)EBO}$	$I_E = 10\mu\text{A}, I_C = 0$	5	–	–	V
Collector Cutoff Current	I_{CEV}	$V_{CE} = 50\text{V}, V_{BE(off)} = 3\text{V}$	15	–	–	nA
Base Cutoff Current	I_{BL}	$V_{CE} = 50\text{V}, V_{EB(off)} = 3\text{V}$	30	–	–	nA
ON Characteristics (Note 2)						
DC Current Gain	h_{FE}	$I_C = 0.1\text{mA}, V_{CE} = 10\text{V}$	20	50	–	
		$I_C = 1.0\text{mA}, V_{CE} = 10\text{V}$	25	55	–	
		$I_C = 10\text{mA}, V_{CE} = 10\text{V}$	35	65	–	
		$I_C = 150\text{mA}, V_{CE} = 1.0\text{V}$	20	65	–	
		$I_C = 150\text{mA}, V_{CE} = 10\text{V}$	40	30	120	
		$I_C = 300\text{mA}, V_{CE} = 10\text{V}$	25	75	–	
Collector–Emitter Saturation Voltage	$V_{CE(sat)}$	$I_C = 150\text{mA}, I_B = 15\text{mA}$	–	0.2	0.4	V
		$I_C = 300\text{mA}, I_B = 30\text{mA}$	–	0.35	1.2	V
Base–Emitter Saturation Voltage	$V_{BE(sat)}$	$I_C = 150\text{mA}, I_B = 15\text{mA}$	0.6	0.95	1.3	V
		$I_C = 300\text{mA}, I_B = 30\text{mA}$	–	–	2.0	V
Small–Signal Characteristics						
Current Gain–Bandwidth Product	f_T	$I_C = 20\text{mA}, V_{CE} = 20\text{V}, f = 100\text{MHz}$	200	250	–	MHz
Output Capacitance	C_{obo}	$V_{CB} = 10\text{V}, I_E = 0, f = 100\text{kHz}$	–	3.5	8.0	pF
Input Capacitance	C_{ibo}	$V_{EB} = 0.5\text{V}, I_C = 0, f = 100\text{kHz}$	–	15	20	pF
Switching Characteristics						
Delay Time	t_d	$V_{CC} = 30\text{V}, I_C = 150\text{mA}, V_{BE(off)} = 0.5\text{V}, I_{B1} = 15\text{mA}$	–	–	15	μs
Rise Time	t_r		–	–	30	μs
Storage Time	t_s	$V_{CC} = 30\text{V}, I_C = 150\text{mA}, I_{B1} = I_{B2} = 15\text{mA}$	–	–	250	μs
Fall Time	t_f		–	–	60	μs

Note 2. Pulse Test: Pulse Width $\leq 300\mu\text{s}$, Duty Cycle $\leq 2\%$.

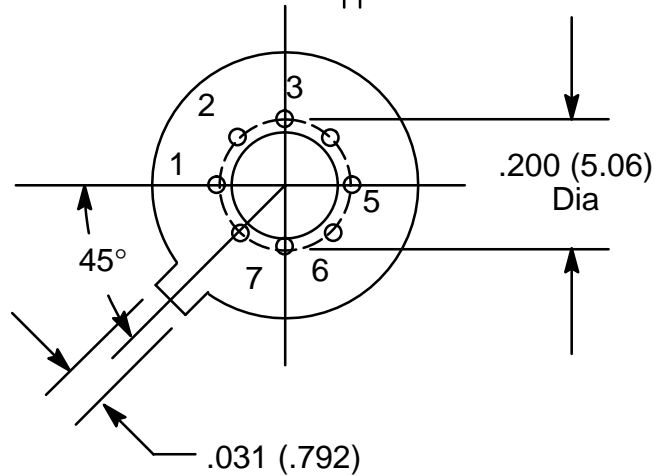
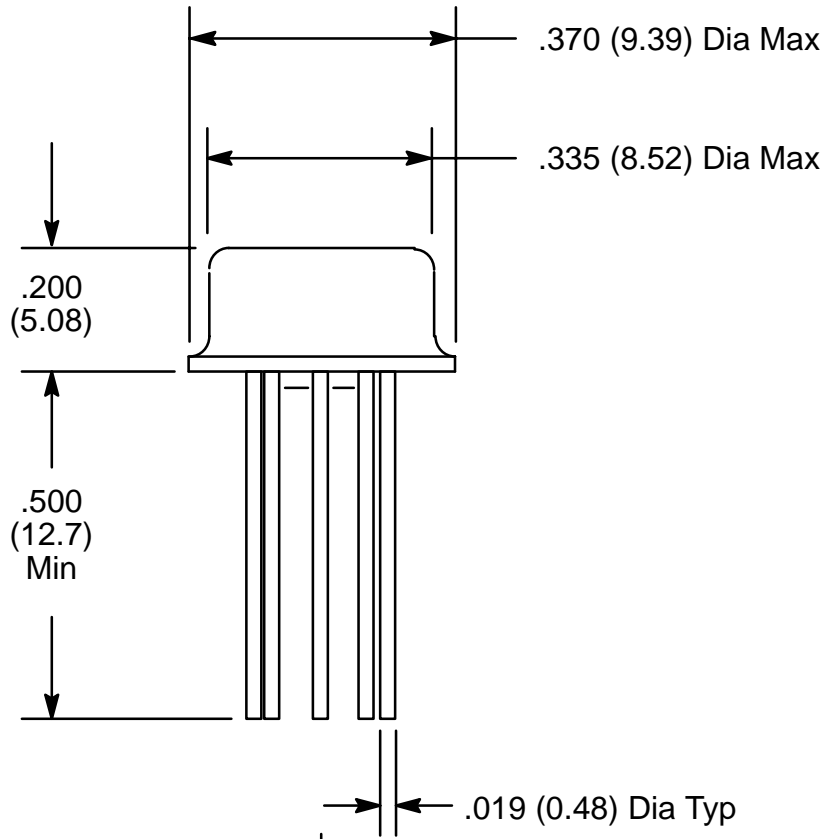

Pin4 and Pin8 Omitted

- Pin 1. C1
- 2. B1
- 3. E1
- 5. E2
- 6. B2
- 7. C2