

SMBus/I²C Interfaced 9-Port, Level-Translating GPIO and LED Driver with CLA

General Description

The MAX7302 I²C-/SMBus™-compatible, serial-interfaced peripheral features 9 level-translating I/Os, and operates from a 1.62V to 3.6V power supply. The MAX7302 features a port supply V_{LA} that allows level-translation on I/O ports to operate from a separate power supply from 1.62V to 5.5V. An address select input, ADO, allows up to four unique slave addresses for the device.

The MAX7302 ports P2–P9 can be configured as inputs, push-pull outputs, and open-drain outputs. Port P1 can be configured as a general-purpose input, open-drain output, or an open-drain INT output. Ports P2–P9 can be configured as OSCIN and OSCOUT, respectively. Ports P2–P9 can also be used as configurable logic arrays (CLAs) to form user-defined logic gates, replacing external discrete gates. Outputs are capable of sinking up to 25mA, and sourcing up to 10mA when configured as push-pull outputs.

The MAX7302 includes an internal oscillator for PWM, blink, and key debounce, or to cascade multiple MAX7302s. The external clock can be used to set a specific PWM and blink timing. The \overline{RST} input asynchronously clears the 2-wire interface and terminates a bus lockup involving the MAX7302.

All ports configured as an output feature a 33-step PWM, allowing any output to be set from fully off, 1/32 to 31/32 duty cycle, to fully on. All output ports also feature LED blink control, allowing blink periods of 1/8s, 1/4s, 1/2s, 1s, 2s, 4s, or 8s. Any port can blink during this period with a 1/16 to 15/16 duty cycle.

The MAX7302 is specified over the -40°C to +125°C temperature range and is available in 16-pin QSOP and 16-pin TQFN (3mm x 3mm) packages.

Applications

- Cell Phones
- Servers
- System I/O Ports
- LCD/Keypad Backlights
- LED Status Indicators

Pin Configurations appear at end of data sheet.

SMBus is a trademark of Intel Corp.

Features

- ◆ 1.62V to 5.5V I/O Level-Translation Port Supply (V_{LA})
- ◆ 1.62V to 3.6V Power Supply
- ◆ 9 Individually Configurable GPIO Ports
 - P1 Open-Drain I/O
 - P2–P9 Push-Pull or Open-Drain I/Os
- ◆ Individual 33-Step PWM Intensity Control
- ◆ Blink Controls with 15 Steps on Outputs
- ◆ 1kHz PWM Period Provides Flicker-Free LED Intensity Control
- ◆ 25mA (max) Port Output Sink Current (100mA max Ground Current)
- ◆ Inputs Overvoltage Protected Up to 5.5V (V_{LA})
- ◆ Transition Detection with Optional Interrupt Output
- ◆ Optional Input Debouncing
- ◆ I/O Ports Configurable as Logic Gates (CLA)
- ◆ External \overline{RST} Input
- ◆ Oscillator Input and Output Enable Cascading Multiple Devices
- ◆ Low 0.75 μ A (typ) Standby Current

Ordering Information

PART	TEMP RANGE	PIN-PACKAGE	PKG CODE
MAX7302AEE+	-40°C to +125°C	16 QSOP	E16-4
MAX7302ATE+	-40°C to +125°C	16 TQFN-EP* (3mm x 3mm)	T1633-4

+Denotes lead-free package.

*EP = Exposed paddle.

Typical Operating Circuit

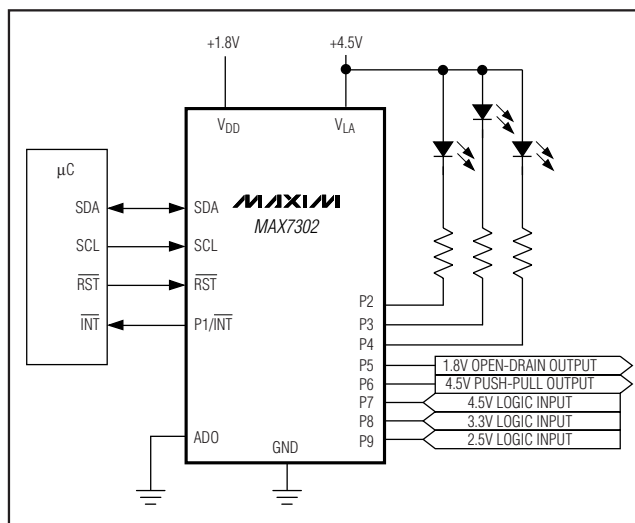

SMBus/I²C Interfaced 9-Port, Level-Translating GPIO and LED Driver with CLA

ABSOLUTE MAXIMUM RATINGS

(All voltages referenced to GND.)

V _{DD}	-0.3V to +4V	GND Current	100mA
V _{LA} , SCL, SDA, AD0, RST, P1	-0.3V to +6V	Continuous Power Dissipation (T _A = +70°C)	
P2–P9	-0.3V to V _{LA} + 0.3V	16-Pin QSOP (derate 8.3mW/°C over +70°C).....	666mW
P1–P9 Sink Current	25mA	16-Pin TQFN (derate 14.7mW/°C over +70°C).....	1176mW
P2–P9 Source Current	10mA	Operating Temperature Range	-40°C to +125°C
SDA Sink Current	10mA	Junction Temperature.....	+150°C
V _{DD} Current	10mA	Storage Temperature Range	-65°C to +150°C
V _{LA} Current	35mA	Lead Temperature (soldering, 10s).....	+300°C

Stresses beyond those listed under "Absolute Maximum Ratings" may cause permanent damage to the device. These are stress ratings only, and functional operation of the device at these or any other conditions beyond those indicated in the operational sections of the specifications is not implied. Exposure to absolute maximum rating conditions for extended periods may affect device reliability.

ELECTRICAL CHARACTERISTICS

(V_{DD} = 1.62V to 3.6V, T_A = T_{MIN} to T_{MAX}, unless otherwise noted. Typical values are at V_{DD} = 3.3V, V_{LA} = 3.3V, T_A = +25°C.) (Note 1)

PARAMETER	SYMBOL	CONDITIONS	MIN	TYP	MAX	UNITS
Operating Supply Voltage	V _{DD}		1.62		3.60	V
Port Logic Supply Voltage	V _{LA}		1.62		5.50	V
Power-On-Reset Voltage	V _{POR}	V _{DD} rising	1.0	1.3	1.6	V
Power-On-Reset Hysteresis	V _{PORHYST}		10	158	300	mV
Standby Current (Interface Idle)	I _{STB}	Internal oscillator disabled; SCL, SDA, digital inputs at V _{DD} or GND; P1–P9 (as inputs) at V _{LA} or GND		0.75	2	μA
	I _{OSC}	Internal oscillator enabled; SCL, SDA, digital inputs at V _{DD} or GND; P1–P9 (as inputs) at V _{LA} or GND		17	25	
Supply Current (Interface Running)	I _{SUP}	f _{SCL} = 400kHz; other digital inputs at V _{DD} or GND		31	40	μA
Port Supply Current (V _{LA})	I _{VLA}	Port inputs at V _{LA} or GND		0.06	5	μA
Input High Voltage SDA, SCL, AD0, RST	V _{IH}		0.7 × V _{DD}			V
Input Low Voltage SDA, SCL, AD0, RST	V _{IL}			0.3 × V _{DD}		V
Input High Voltage P1–P9	V _{IHP}	Input is V _{DD} referred	0.7 × V _{DD}			V
Input Low Voltage P1–P9	V _{ILP}	Input is V _{DD} referred		0.3 × V _{DD}		V
Input High Voltage P1–P9	V _{IHPA}	Input is V _{LA} referred	0.7 × V _{LA}			V
Input Low Voltage P1–P9	V _{ILPA}	Input is V _{LA} referred		0.3 × V _{LA}		V
Input Leakage Current SDA, SCL, AD0, RST	I _{IH} , I _{IL}	V _{DD} or GND	-1		+1	μA
Input Leakage Current P1–P9	I _{IHP} , I _{ILP}	V _{LA} or GND	-2		+2	μA
Input Capacitance SDA, SCL, AD0, P1–P9, RST				8		pF
Output Low Voltage P1–P9	V _{OL}	V _{DD} = 1.62V, I _{SINK} = 3mA		0.05	0.11	V
		V _{DD} = 2.5V, I _{SINK} = 16mA		0.19	0.31	
		V _{DD} = 3.3V, I _{SINK} = 20mA		0.19	0.31	
Output High Voltage P2–P9	V _{OH}	V _{LA} = 1.62V, I _{SOURCE} = 0.5mA	1.55	1.58		V
		V _{LA} ≥ 2.5V, I _{SOURCE} = 5mA	V _{LA} - 0.4	2.32		
		V _{LA} ≥ 3.3V, I _{SOURCE} = 10mA	V _{LA} - 0.6	3.1		
Output Low Voltage SDA	V _{OLSDA}	I _{SINK} = 6mA			0.3	V

SMBus/I²C Interfaced 9-Port, Level-Translating GPIO and LED Driver with CLA

PORT, INTERRUPT ($\overline{\text{INT}}$), AND RESET ($\overline{\text{RST}}$) TIMING CHARACTERISTICS

($V_{DD} = 1.62\text{V}$ to 3.6V , $T_A = T_{MIN}$ to T_{MAX} , unless otherwise noted. Typical values are at $V_{DD} = 3.3\text{V}$, $V_{LA} = 3.3\text{V}$, $T_A = +25^\circ\text{C}$.) (Note 1) (Figures 10, 15, 16 and 17)

PARAMETER	SYMBOL	CONDITIONS	MIN	TYP	MAX	UNITS
Oscillator Frequency	f_{CLK}	$f_{CLK} = \text{internal oscillator}$		32		kHz
		$f_{CLK} = \text{OSCIN external input}$			1	MHz
Port Output Data Valid High Time	t_{PPVH}	$C_L \leq 100\text{pF}$			4	μs
Port Output Data Valid Low Time (Note 6)	t_{PPVL}	$C_L \leq 100\text{pF}$ (Note 2)			$1/f_{CLK}$	s
Port Input Setup Time	t_{PSU}	$C_L = 100\text{pF}$	0			μs
Port Input Hold Time	t_{PH}	$C_L = 100\text{pF}$	4			μs
CLA Rise Time P5, P9 as Push-Pull Outputs	t_{RFCLA}	$C_L = 100\text{pF}$, $V_{LA} \geq 2.7\text{V}$		17		ns
CLA Fall Time P5, P9 as Push-Pull Outputs				14		
CLA Propagation Delay P2, P3, or P4 to P5; P6, P7, or P8 to P9	t_{PDCLA}	$C_L = 100\text{pF}$, $V_{LA} \geq 2.7\text{V}$		28	50	ns
$\overline{\text{INT}}$ Input Data Valid Time	t_{IV}	$C_L = 100\text{pF}$			4	μs
$\overline{\text{INT}}$ Reset Delay Time from Acknowledge	t_{IR}	$C_L = 100\text{pF}$			4	μs
$\overline{\text{RST}}$ Rising to START Condition Setup Time	t_{RST}		900			ns
$\overline{\text{RST}}$ Pulse Width	t_W		500			ns

SERIAL INTERFACE TIMING CHARACTERISTICS

($V_{DD} = 1.62\text{V}$ to 3.6V , $T_A = T_{MIN}$ to T_{MAX} , unless otherwise noted. Typical values are at $V_{DD} = 3.3\text{V}$, $V_{LA} = 3.3\text{V}$, $T_A = +25^\circ\text{C}$.) (Note 1) (Figure 10)

PARAMETER	SYMBOL	CONDITIONS	MIN	TYP	MAX	UNITS
Serial-Clock Frequency	f_{SCL}				400	kHz
Bus Timeout	$t_{TIMEOUT}$			31		ms
Bus Free Time Between a STOP and a START Condition	t_{BUF}		1.3			μs
Hold Time, (Repeated) START Condition	$t_{HD,STA}$		0.6			μs
Repeated START Condition Setup Time	$t_{SU,STA}$		0.6			μs
STOP Condition Setup Time	$t_{SU,STO}$		0.6			μs
Data Hold Time	$t_{HD,DAT}$	(Note 3)			0.9	μs
Data Setup Time	$t_{SU,DAT}$		100			ns
SCL Clock Low Period	t_{LOW}		1.3			μs
SCL Clock High Period	t_{HIGH}		0.7			μs
Rise Time of Both SDA and SCL Signals, Receiving	t_R	(Notes 2, 4)		$20 + 0.1C_b$	300	ns
Fall Time of Both SDA and SCL Signals, Receiving	t_F	(Notes 2, 4)		$20 + 0.1C_b$	300	ns
Fall Time of SDA Transmitting	$t_{F,TX}$	(Note 4)		$20 + 0.1C_b$	250	ns
Pulse Width of Spike Suppressed	t_{SP}	(Note 5)		50		ns
Capacitive Load for Each Bus Line	C_b	(Note 2)			400	pF

Note 1: All parameters are tested at $T_A = +25^\circ\text{C}$. Specifications over temperature are guaranteed by design.

Note 2: Guaranteed by design.

Note 3: A master device must provide a hold time of at least 300ns for the SDA signal (referred to V_{IL} of the SCL signal) to bridge the undefined region of SCL's falling edge.

Note 4: C_b = total capacitance of one bus line in pF. t_R and t_F are measured between $0.3 \times V_{DD}$ and $0.7 \times V_{DD}$.

Note 5: Input filters on the SDA and SCL inputs suppress noise spikes less than 50ns.

Note 6: A startup time is required for the internal oscillator to start if it is not running already.

SMBus/I²C Interfaced 9-Port, Level-Translating GPIO and LED Driver with CLA

Typical Operating Characteristics

(V_{DD} = 3.3V, V_{LA} = 3.3V and T_A = +25°C, unless otherwise noted.)

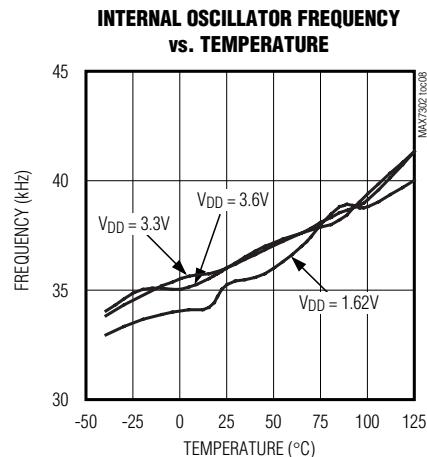
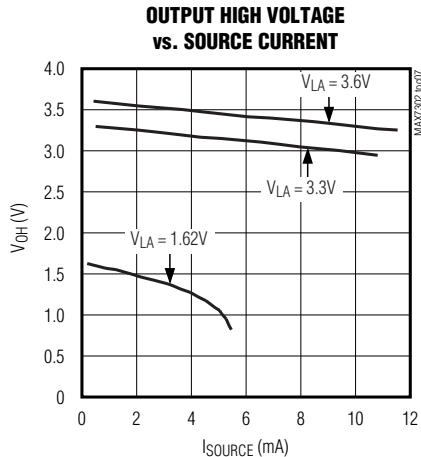
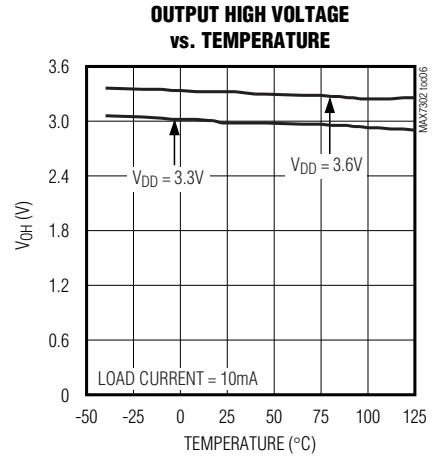
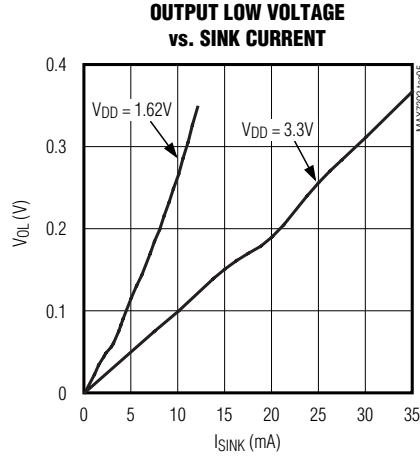
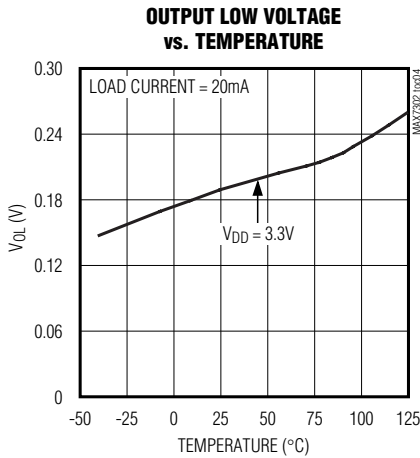
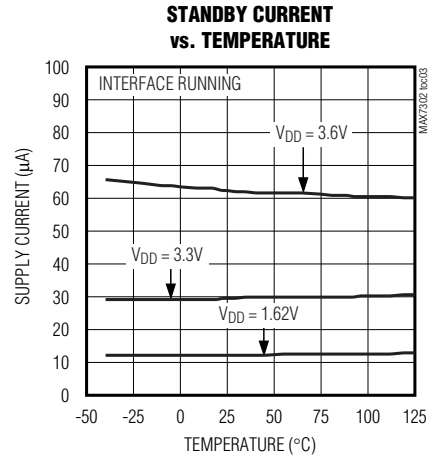
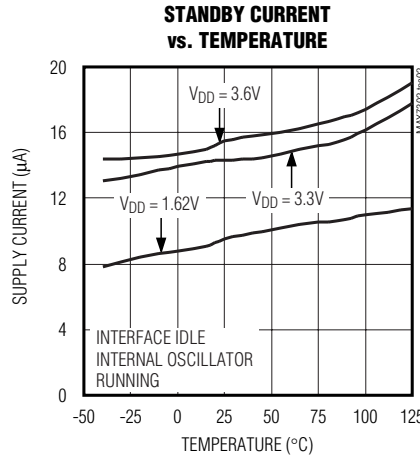
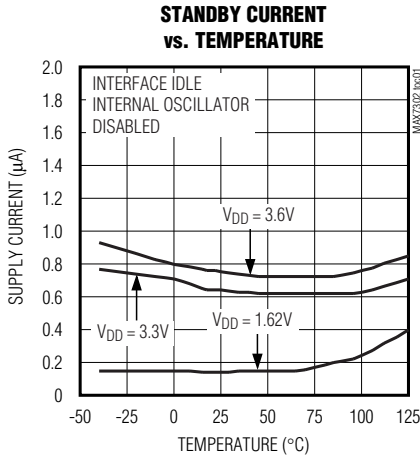

SMBus/I²C Interfaced 9-Port, Level-Translating GPIO and LED Driver with CLA

MAX7302

Typical Operating Characteristics (continued)

(V_{DD} = 3.3V, V_{LA} = 3.3V and T_A = +25°C, unless otherwise noted.)

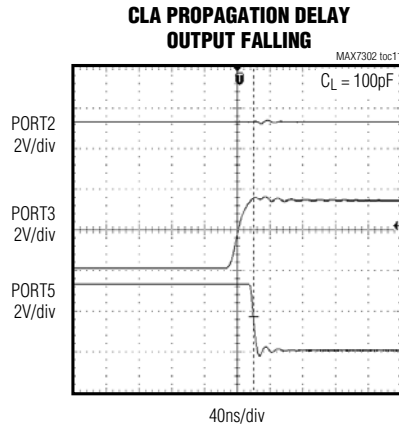
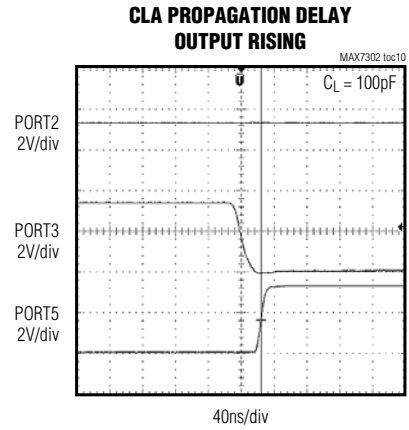
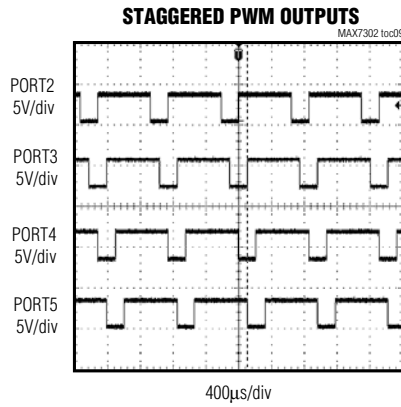

SMBus/I²C Interfaced 9-Port, Level-Translating GPIO and LED Driver with CLA

Pin Description

PIN		NAME	FUNCTION
QSOP	TQFN		
1	15	V _{LA}	Port Supply for P1–P9. Connect V _{LA} to a power supply between 1.62V and 5.5V. Bypass V _{LA} to GND with a 0.047μF ceramic capacitor.
2	16	AD0	Address Input. Sets the device slave address. Connect to GND, V _{DD} , SCL, or SDA to provide four address combinations.
3	1	$\overline{\text{RST}}$	Reset Input. $\overline{\text{RST}}$ is an active-low input, referenced to V _{DD} , that clears the 2-wire interface and can be configured to put the device in the power-up reset and/or to reset the PWM and blink timing.
4	2	P1/ $\overline{\text{INT}}$	Input/Output Port. P1/ $\overline{\text{INT}}$ is a general-purpose I/O that can be configured as a transition detection interrupt output.
5	3	P2/OSCIN	Input/Output Port. P2/OSCIN is a general-purpose I/O that can be configured as the oscillator input for PWM and blink features.
6	4	P3/OSCOU	Input/Output Port. P3/OSCOU is a general-purpose I/O that can be configured as the PWM/blink/timing oscillator output for PWM and blink features.
7, 8, 9, 11, 12, 13	5, 6, 7, 9, 10, 11	P4–P9	Input/Output Ports. P4–P9 are general-purpose I/Os.
10	8	GND	Ground
14	12	SCL	Serial-Clock Input
15	13	SDA	Serial-Data I/O
16	14	V _{DD}	Positive Supply Voltage. Bypass V _{DD} to GND with a 0.047μF ceramic capacitor.
—	EP	EP	Exposed Paddle on Package Underside. Connect to GND.

SMBus/I²C Interfaced 9-Port, Level-Translating GPIO and LED Driver with CLA

Block Diagram

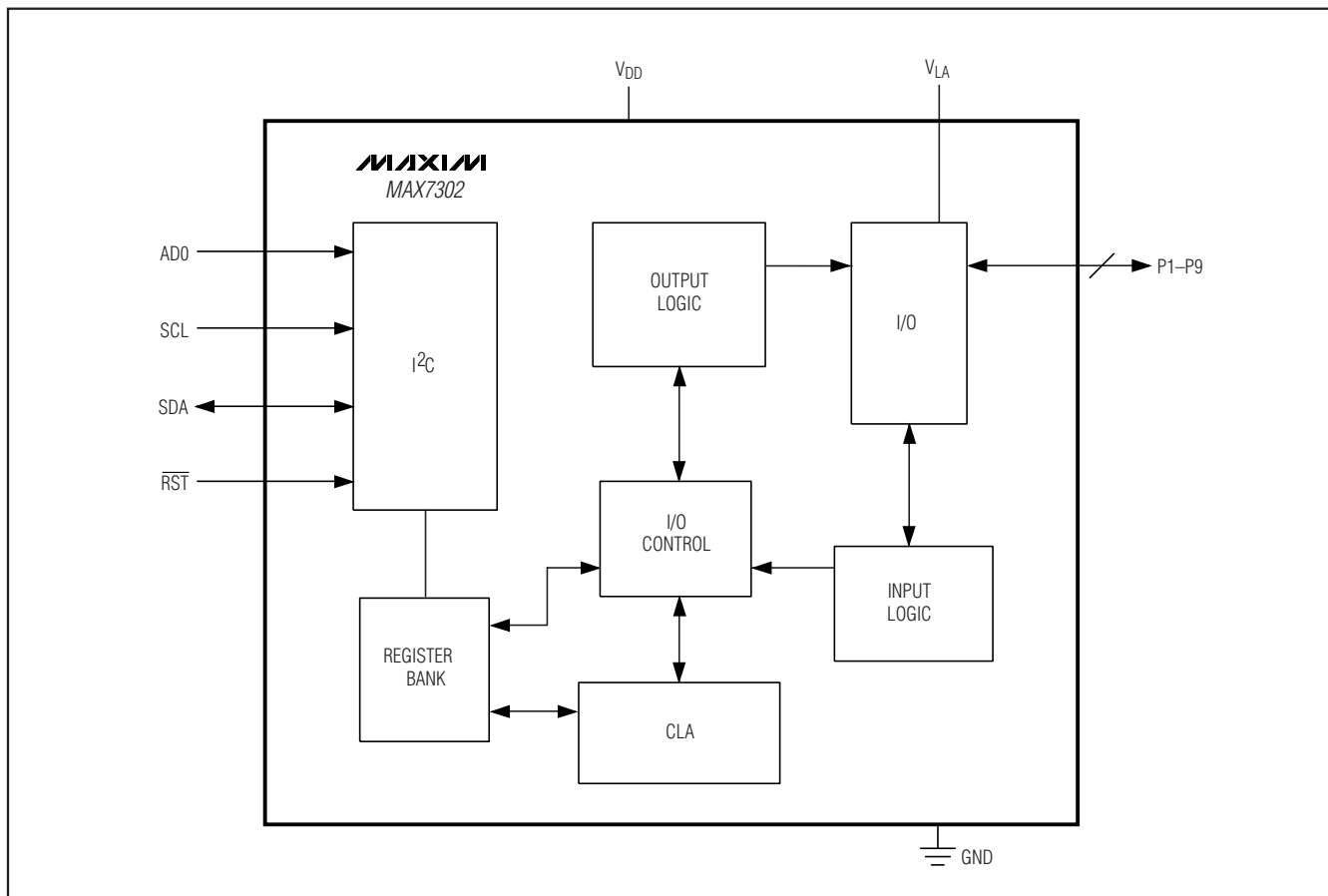

MAX7302

Detailed Description

The MAX7302 9-port, general-purpose port expander operates from a 1.62V to 3.6V power supply. Port P1 can be configured as an input and an open-drain output. Port P1 can also be configured to function as an INT output. Ports P2–P9 can be configured as inputs, push-pull outputs, and open-drain outputs. Ports P2–P9 can be used as simple configurable logic arrays (CLAs) to form user-defined logic gates.

Each port configured as an open-drain or push-pull output can sink up to 25mA. Push-pull outputs also have a 5mA source drive capability. The MAX7302 is rated to sink a total of 100mA into any combination of

its output ports. Output ports have PWM and blink capabilities, as well as logic drive.

Initial Power-Up

On power-up, the MAX7302 default configuration has all 9 ports, P1–P9, configured as input ports with logic levels referenced to V_{LA} . The transition detection interrupt status flag resets and stays high (see Tables 1 and 2).

Device Configuration Registers

The device configuration registers set up the interrupt function, serial-interface bus timeout, and PWM/blink oscillator options, global blink period, and reset options (see Tables 3 and 4).

SMBus/I²C Interfaced 9-Port, Level-Translating GPIO and LED Driver with CLA

Table 1. Register Address Map

REGISTER	ADDRESS	AUTOINCREMENT ADDRESS	POR STATE
Port P1 or INT Output	0x01	0x02	0x80
Port P2 or OSCIN Input	0x02	0x03	0x80
Port P3 or OSCOUT Output	0x03	0x04	0x80
Port P4	0x04	0x05	0x80
Port P5	0x05	0x06	0x80
Port P6	0x06	0x07	0x80
Port P7	0x07	0x08	0x80
Port P8	0x08	0x09	0x80
Port P9	0x09	0x0A or 0x4A	0x80
Configuration 26	0x26	0x27	0xCC
Configuration 27	0x27	0x28	0x8F
Ports P2–P5 Configurable Logic CLA0	0x28	0x29	0x00
Ports P6–P9 Configurable Logic CLA1	0x29	0x2A	0x00
Write Ports P2–P5 Same Data; Read P2	0x3C	0x3D	0x80
Write Ports P6–P9 Same Data; Read P6	0x3D	0x3E	0x80
FACTORY RESERVED (Do not write to these registers)	0x3C–0x3F	0x3F–0x40	0x00
CLA0 and CLA1 Configurable Logic Enable	0x70	0x71	0x00
CLA0 and CLA1 Configurable Logic Lock	0x71	0x72	0x00
Configuration 67 Lock, Ports P1–P5 Lock	0x72	0x73	0x00
Ports P6–P9 Lock	0x73	0x74	0xF0
FACTORY RESERVED (Do not write to these registers)	0x00	0x01	0x80

Table 2. Power-Up Register Status

REGISTER	POWER-UP CONDITION	ADDRESS CODE (HEX)	REGISTER DATA							
			D7	D6	D5	D4	D3	D2	D1	D0
Ports P1–P9	Ports P _n are V _{LA} -referred input ports with interrupt and debounce disabled	0x01–0x09	1	0	0	0	0	0	0	0
Configuration 26	RST does not reset registers or counters; blink period is 1Hz; transition flag clear; interrupt status flag clear	0x26	1	1	0	0	1	1	0	0
Configuration 27	Ports P1–P9 are GPIO ports; bus timeout is disabled	0x27	1	0	0	0	1	1	1	1
Ports CLA0 to CLA1	Default gate structure	0x28–0x29	0	0	0	0	0	0	0	0
CLA0 to CLA1	CLA not enable	0x70	0	0	0	0	0	0	0	0
Configuration 27 Lock, Ports P1–P5 Lock	Configuration 27 is not locked; ports P1–P5 are not locked	0x72	0	0	0	0	0	0	0	0
Ports P6–P9 Lock	Ports P6–P9 are not locked	0x73	1	1	1	1	0	0	0	0

SMBus/I²C Interfaced 9-Port, Level-Translating GPIO and LED Driver with CLA

MAX7302

Table 3. Configuration Register (0x26)

REGISTER BIT	DESCRIPTION	VALUE	FUNCTION
D7	Interrupt status flag (read only)	0	An interrupt has occurred on at least one interrupt enabled input port.
		1*	No interrupt has occurred on an interrupt enabled input port.
D6	Transition flag (read only)	0	A transition has occurred on an input port.
		1*	No transition has occurred on an input port.
D5	Reserved	—	Reserved
D4, D3, D2	Blink prescaler bits	0/1	Blink timer bits, see Table 10.
D1	$\overline{\text{RST}}$ timer	0*	$\overline{\text{RST}}$ does not reset counters PWM/blink
		1	$\overline{\text{RST}}$ resets PWM/blink counters
D0	$\overline{\text{RST}}$ POR	0*	$\overline{\text{RST}}$ does not reset registers to power-on-reset state.
		1	$\overline{\text{RST}}$ resets registers to power-on-reset state.

*Default state.

Table 4. Configuration Register (0x27)

REGISTER BIT	DESCRIPTION	VALUE	FUNCTION
D7	Bus timeout	0	Enables the bus timeout feature.
		1	Disables the bus timeout feature.
D6, D5, D4	Reserved	0	Reserved
		1	Reserved
D3	P3/OSCOUT	0	Sets P3 to output the oscillator.
		1*	Sets P3 as a GPIO controlled by register 0x03.
D2	P2/OSCIN	0	Sets P2 as the oscillator input.
		1*	Sets P2 as a GPIO controlled by register 0x02.
D1	P1/INT output	0	Sets P1 as the interrupt output.
		1	Sets P1 as a GPIO controlled by register 0x01.
D0	Input transition	0	Set to 0 on power-up to detect transition on inputs.

*Default state.

SMBus/I²C Interfaced 9-Port, Level-Translating GPIO and LED Driver with CLA

Slave Address

The MAX7302 is set to one of four I²C slave addresses, using the address input AD0 (see Table 5) and is accessed over an I²C or SMBus serial interface up to 400kHz. The MAX7302 slave address is determined on each I²C transmission, regardless of whether or not the transmission is actually addressing the device. The MAX7302 distinguishes whether address input AD0 is connected to SDA, SCL, V_{DD}, or GND during the transmission. Therefore, the MAX7302 slave address can be configured dynamically in an application without toggling the device supply.

I/O Port Registers

The port I/O registers set the I/O ports, one register per port (see Tables 6 and 7). Ports can be independently configured as inputs or outputs (D7), push-pull or open drain (D6). Port P1 can only be configured as an input or an open-drain output. The push-pull bit (D6) setting for the port I/O register P1 is ignored.

I/O Input Port

Configure a port as an input by writing a logic-high to the MSB (bit D7) of the port I/O register (see Table 6). See Figure 1 for input port structure. To obtain the logic

level of the port input, read the port I/O register bit, D0. This readback value is the instantaneous logic level at the time of the read request if debounce is disabled for the port (port I/O register bit D2 = 0), or the debounced result if debounce is enabled for the port (port I/O register bit D2 = 1).

I/O Output Port

Configure a port as an output by writing a logic-low to the MSB (bit D7) of the port I/O register. See Figures 2 and 3 for output port structure. The device reads back the logic level, PWM, or the blink setting of the port (see Table 7). The MAX7302 monitors the logic level of ports configured as CLA outputs (see the *Configurable Logic Array (CLA)* section).

Port Supplies and Level Translation

The port supply, V_{LA}, provides the logic supplies to all push-pull I/O ports. Ports P2–P9 can be configured as push-pull I/O ports (see Figure 3). V_{LA} powers the logic-high port output voltage sourcing the logic-high port load current. V_{LA} provides level translation capability for the outputs and operates over a 1.62V to 5.5V voltage independent of the MAX7302 power-supply voltage, V_{DD}.

Each port set as an input can be configured to switch midrail of either the V_{DD} or the V_{LA} port supplies. Whenever the port supply reference is changed from V_{DD} to V_{LA}, or vice versa, read the port register to clear any transition flag on the port.

Table 5. Slave Address Selection

AD0 CONNECTION	DEVICE ADDRESS								R	W
	A6	A5	A4	A3	A2	A1	A0			
GND	1	0	0	1	1	0	0	0	1	
V _{DD}	1	0	0	1	1	0	1	0	1	
SCL	1	0	0	1	1	1	0	0	1	
SDA	1	0	0	1	1	1	1	0	1	

Table 6. Port I/O Registers (I/O Port Set as an Input, Registers 0x01/0x41 to 0x09/049)

REGISTER BIT	DESCRIPTION	VALUE	FUNCTION
D7	Port I/O set bit	1	Sets the I/O port as an input.
D6	Port supply reference	0	Refers the input to the V _{LA} supply voltage.
		1	Refers the input to the V _{DD} supply voltage.
D5	Transition interrupt enable	0	Disables the transition interrupt.
		1	Enables the transition interrupt.
D4, D3	Reserved bits	0	Do not write to these registers.
D2	Debounce	0	Disables debouncing of the input port.
		1	Enables debouncing of the input port.
D1	Port transition state (read only)	0	No transition has occurred since the last port read.
		1	A transition has occurred since the last port read.
D0	Port status (read only)	0	Port input is logic-low.
		1	Port input is logic-high.

SMBus/I²C Interfaced 9-Port, Level-Translating GPIO and LED Driver with CLA

MAX7302

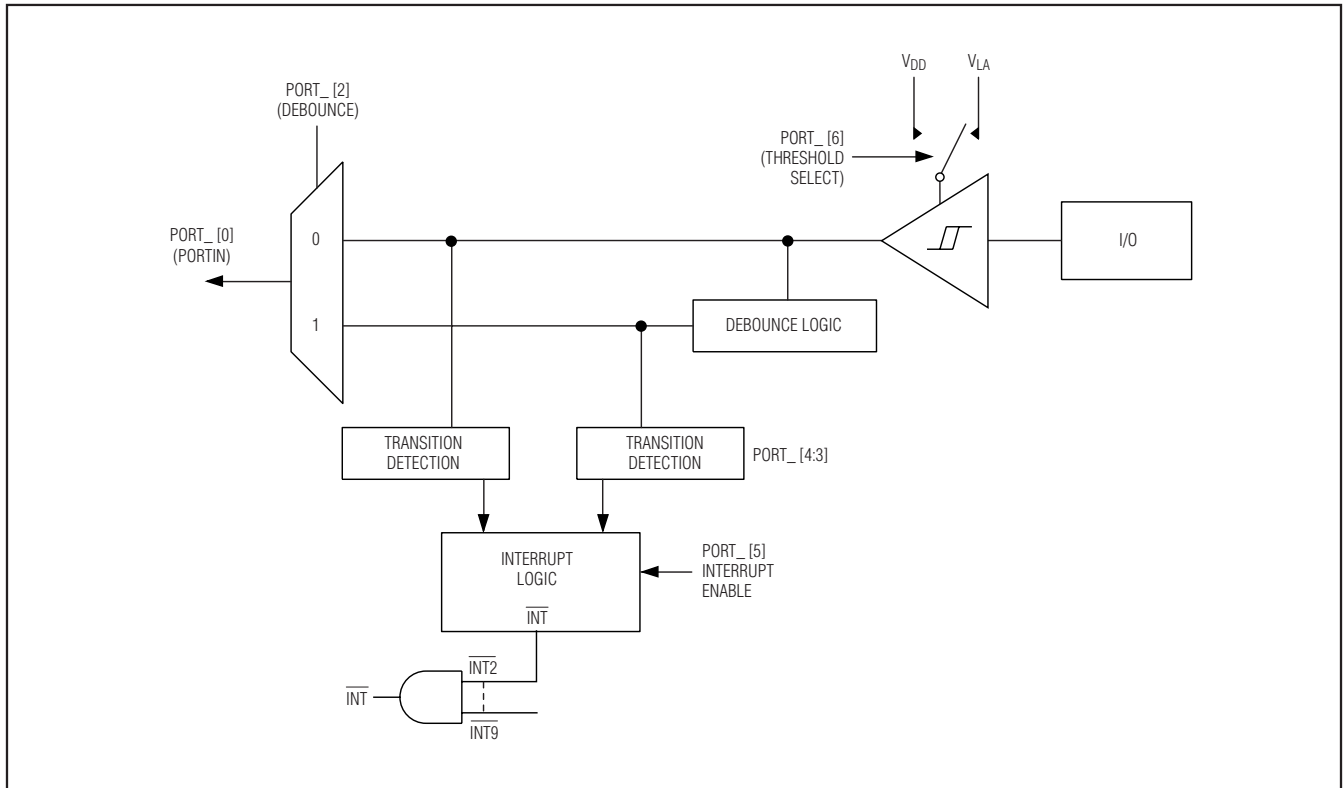

Figure 1. Input Port Structure

Table 7. Port I/O Registers (I/O Port Set as an Output, Registers 0x01 to 0x09)

REGISTER BIT	DESCRIPTION	VALUE	FUNCTION
D7	Port I/O set bit	0	Sets the I/O port as an output.
D6	Output port set to push-pull or open drain	0	Sets the output type to open drain.
		1	Sets the output type to push-pull.
D5	PWM/blink enable	0	Sets the output to PWM mode.
		1	Sets the output to blink mode.
D4	Duty-cycle bit 4	0/1	MSB of the 5-bit duty-cycle setting. See Tables 9 and 11.
D3	Duty-cycle bit 3	0/1	Bit 3 of the 5-bit duty-cycle setting. See Tables 9 and 11.
D2	Duty-cycle bit 2	0/1	Bit 2 of the 5-bit duty-cycle setting. See Tables 9 and 11.
D1	Duty-cycle bit 1	0/1	Bit 1 of the 5-bit duty-cycle setting. See Tables 9 and 11.
D0	Duty-cycle bit 0	0/1	LSB of the 5-bit duty-cycle setting. See Tables 9 and 11.

SMBus/I²C Interfaced 9-Port, Level-Translating GPIO and LED Driver with CLA

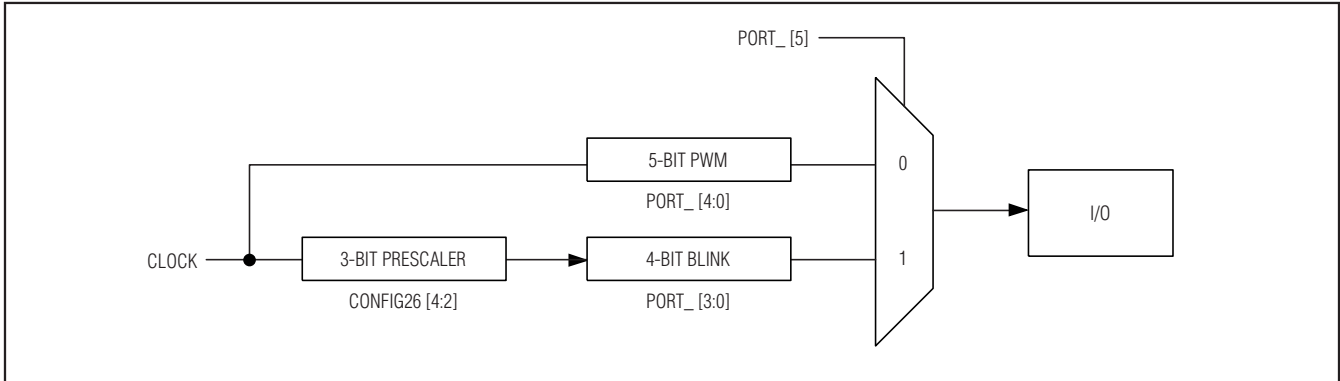

Figure 2. Output Port Structure

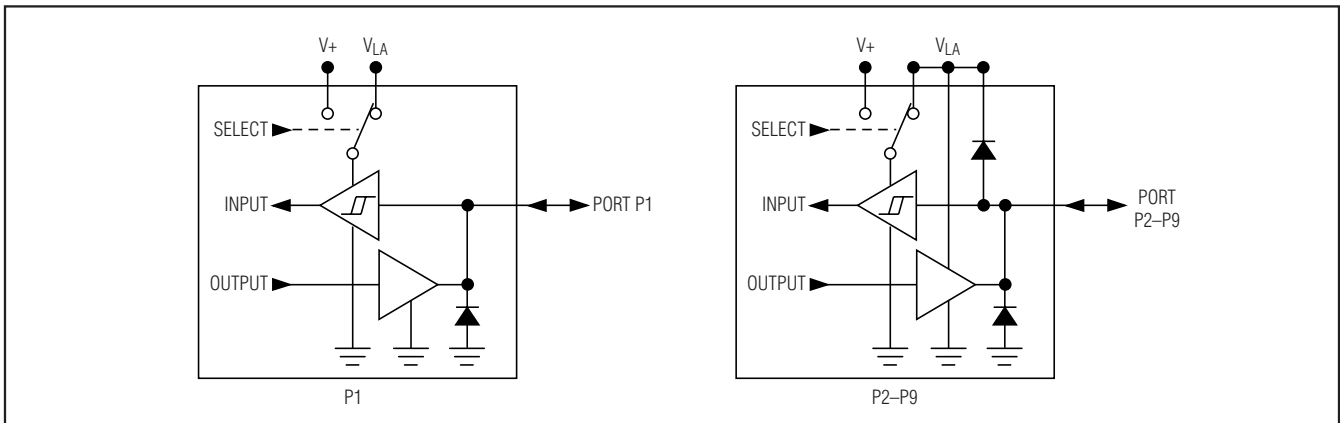

Figure 3. Port I/O Structure

Ports P2–P9 are overvoltage protected to V_{LA} . This is true even for a port used as an input with a V_{DD} port logic-input threshold. Port P1 is overvoltage protected to 5.5V, independent of V_{DD} and V_{LA} (see Figure 3). To mix logic outputs with more than one voltage swing on a group of ports using the same port supply, set the port supply voltage (V_{LA}) to be the highest output voltage. Use push-pull outputs and port P1 for the highest voltage ports, and use open-drain outputs with external pullup resistors for the lower voltage ports. When P2–P9 are acting as inputs referenced to V_{DD} , make sure the V_{LA} voltage is greater than $V_{DD} - 0.3V$.

Port Lock Registers

Use the port lock registers to lock any combination of port I/O register functionality (see Table 8). The port lock registers are unlocked on power-up or by configuring the RSTPOR bit to reset to POR value. The bits in the port lock register can only be written to once. After setting a bit to logic-high, the bit can only be cleared by powering off the device.

When a bit position in the port lock register is set, the corresponding port I/O registers cannot change. When a port I/O register is locked as an output, none of its output register settings can change. When a port I/O register is locked as an input, only bits D0 and D1 can change, and the locked input behaviour options, such as debounce and transition detection, operate as normal.

Input Debounce

The MAX7302 samples the input ports every 31ms if input debouncing is enabled for an input port ($D2 = 1$ of the port I/O register). The MAX7302 compares each new sample with the previous sample. If the new sample and the previous sample have the same value, the corresponding internal register updates.

When the port input is read through the serial interface, the MAX7302 does not return the instantaneous value of the logic level from the port because debounce is active. Instead, the MAX7302 returns the stored debounced input signal.

SMBus/I²C Interfaced 9-Port, Level-Translating GPIO and LED Driver with CLA

Table 8. Port Lock Registers

ADDRESS CODE	REGISTER DATA							
	D7	D6	D5	D4	D3	D2	D1	D0
0x72	Port P5	Port P4	Port P3	Port P2	Port P1	—	Configuration register 0x27	0
0x73	—	—	—	—	Port P9	Port P8	Port P7	Port P6

When debouncing is enabled for a port input, transition detection applies to the stored debounced input signal value, rather than to the instantaneous value at the input. This process allows for useful transition detection of noisy signals, such as keyswitch inputs, without causing spurious interrupts.

Port Input Transition Detection and Interrupt

Any transition on ports configured as inputs automatically set the D1 bit of that port's I/O registers high. Any input can be selected to assert an interrupt output indicating a transition has occurred at the input port(s). The MAX7302 samples the port input (internally latched into a snapshot register) during a read access to its port P_n I/O register. The MAX7302 continuously compares the snapshot with the port's input condition. If the device detects a change for any port input, an internal transition flag sets for that port. Read register 0x26 to clear the interrupt, then read all the port I/O registers (0x01 to 0x09) by initiating a burst read to clear the MAX7302's internal transition flag. Note that when debouncing is enabled for a port input, transition detection applies to the stored debounced input signal value, rather than to the instantaneous value at the input. Transition bits D4 and D3 must be set to 0 to detect the next rising or falling edge on the input port P_n.

The MAX7302 allows the user to select the input port(s) that cause an interrupt on the $\overline{\text{INT}}$ output. Set $\overline{\text{INT}}$ for each port by using the INTenable bit (bit D5) in each port P_n register. The appropriate port's transition flag always sets when an input changes, regardless of the port's INTenable bit settings. The INTenable bits allow processor interrupt only on critical events, while the inputs and the transition flags can be polled periodically to detect less critical events.

When debounce is disabled, signal transitions between the 9th and 11th falling edges of clock will not be registered since the transition is detected and cleared at the same read cycle.

Ports configured as outputs do not feature transition detection, and therefore, cannot cause an interrupt. The exception to this rule is the CLA outputs.

The $\overline{\text{INT}}$ output never reasserts during a read sequence because this process could cause a recursive reentry into the interrupt service routine. Instead, if a data change occurs during the read that would normally set the $\overline{\text{INT}}$ output, the interrupt assertion is delayed until the STOP condition. If the changed input data is read before the STOP condition, a new interrupt is not required and not asserted. The $\overline{\text{INT}}$ bit and $\overline{\text{INT}}$ output (if selected) have the same value at all times.

Transition Flag

The Transition bit in device configuration register 0x26 is a NOR of all the port I/O registers' individual Transition bits. A port I/O register's Transition bit sets when that port is set as an input, and the input changes from the port's I/O registers last read through the serial interface. A port's individual Transition bit clears by reading that port's I/O register. The Transition flag of configuration register 0x26 is only cleared after reading all port I/O registers on which a transition has occurred.

$\overline{\text{RST}}$ Input

The active-low $\overline{\text{RST}}$ input operates as a hardware reset which voids any on-going I²C transaction involving the MAX7302. This feature allows the MAX7302 supply current to be minimized in power critical applications by effectively disconnecting the MAX7302 from the bus. $\overline{\text{RST}}$ also operates as a chip enable, allowing multiple devices to use the same I²C slave address if only one MAX7302 has its $\overline{\text{RST}}$ input high at any time. $\overline{\text{RST}}$ can be configured to restore all port registers to the power-up settings by setting bit D0 of device configuration register 0x26 (Table 1). $\overline{\text{RST}}$ can also be configured to reset the internal timing counters used for PWM and blink by setting bit D1 of device configuration register 0x26.

When $\overline{\text{RST}}$ is low, the MAX7302 is forced into the I²C STOP condition. The reset action does not clear the interrupt output $\overline{\text{INT}}$. The $\overline{\text{RST}}$ input is referenced to V_{DD} and is overvoltage tolerant up to the supply voltage, V_{LA}.

SMBus/I²C Interfaced 9-Port, Level-Translating GPIO and LED Driver with CLA

\overline{INT} Output

Port P1 can be configured as a latching interrupt output, \overline{INT} , that flags any transients on any combination of selected ports configured as inputs. Configurable logic gate outputs can also be monitored as readback inputs with the same options as normal I/O port inputs. Any transitions occurring at the selected inputs assert \overline{INT} low to alert the host processor of data changes at the selected inputs. Reset \overline{INT} by reading any ports I/O registers (0x01 to 0x09).

Standby Mode

Upon power-up, the MAX7302 enters standby mode when the serial interface is idle. If any of the PWM intensity control, blink, or debounce features are used, the operating current rises because the internal PWM oscillator is running and toggling counters. When using OSCIN to override the internal oscillator, the operating current varies according to the frequency at OSCIN. When the serial interface is active, the operating current also increases because the MAX7302, like all I²C slaves, has to monitor every transmission. The bus timeout and debounce circuits use the internal oscillator even if OSCIN is selected.

Internal Oscillator and OSCIN/OSCOUT External Clock Options

The MAX7302 contains an internal 32kHz oscillator. The MAX7302 always uses the internal oscillator for bus timeout and for debounce timing (when enabled). It is used by default to generate PWM and blink timing. The internal oscillator only runs when the clock output OSCOUT is needed to keep the operating current as low as possible.

The MAX7302 can use an external clock source instead of the internal oscillator for the PWM and blink timing. The external clock can range from DC to 1MHz, and it

connects to the P2/OSCIN port. The P3/OSCOUT port provides a buffered and level-shifted output of the internal oscillator or external clock to drive other devices. Select the P2/OSCIN and P3/OSCOUT port options using the device configuration register 0x67 bits D2 and D3 (see Table 4).

The P2/OSCIN port is overvoltage protected to supply voltage V_{LA} , so the external clock can exceed V_{DD} if V_{LA} is greater than V_{DD} . The port P2 register (see Tables 2 and 6) sets the P2/OSCIN logic threshold (30%/70%) to either the V_{DD} supply or the V_{LA} .

Use OSCOUT or an external clock source to cascade up to four MAX7302s per master for applications requiring additional ports. To synchronize the blink action across multiple MAX7302s (see Figures 4 and 5), use OSCOUT from one MAX7302 to drive OSCIN of the other MAX7302s. This process ensures the same blink frequency of all the devices, but also make sure to synchronize the blink phase. The blink timing of multiple MAX7302s is synchronous at the instant of power-up because the blink and PWM counters clear by each MAX7302's internal reset circuit, and by default the MAX7302s' internal oscillators are off upon power-up.

Ensure that the blink phase of all the devices remains synchronized by programming the OSCIN and OSCOUT functionality before programming any feature that causes a MAX7302's internal oscillator to operate (blink, PWM, bus timeout, or key debounce). Configure the \overline{RST} input to reset the internal timing counters used for PWM and blink by setting bit D1 of device configuration register 0x26 (see Table 3).

PWM and Blink Timing

The MAX7302 divides the 32kHz nominal internal oscillator OSC or external clock source OSCIN frequency by 32 to provide a nominal 1kHz PWM frequency. Use the reset

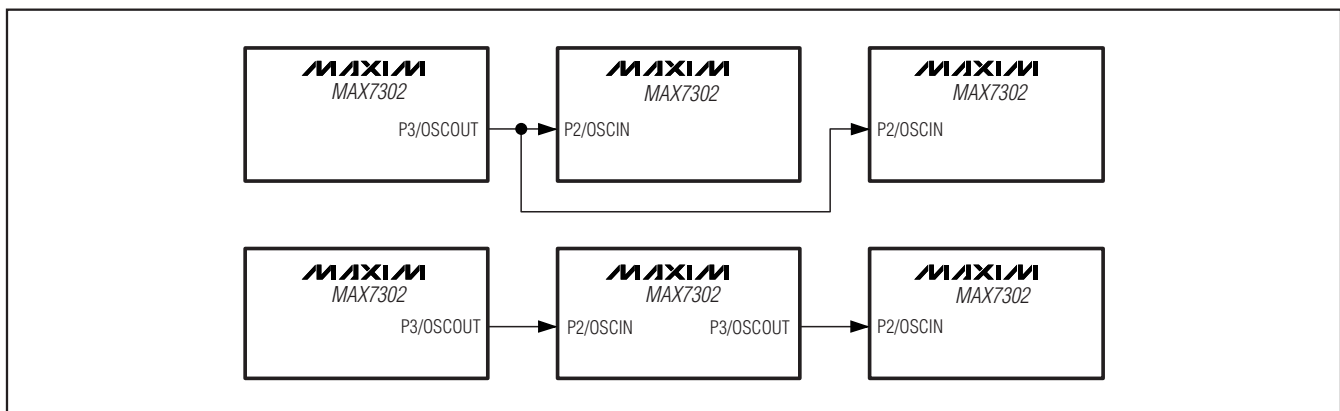

Figure 4. Synchronizing Multiple MAX7302s (Internal Oscillator)

SMBus/I²C Interfaced 9-Port, Level-Translating GPIO and LED Driver with CLA

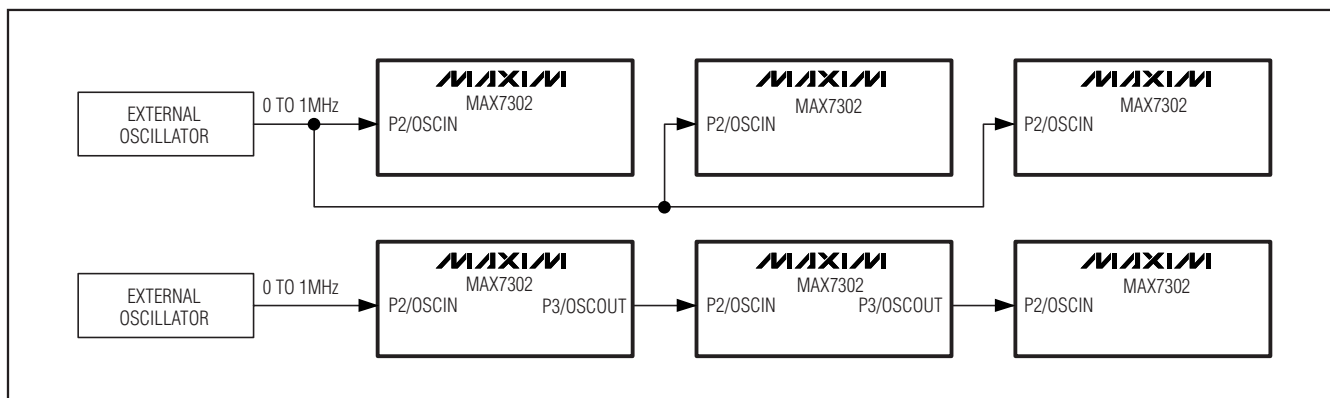

Figure 5. Synchronizing Multiple MAX7302s (External Clock)

Table 9. PWM Settings on Output Port

PWM SETTINGS	REGISTER DATA							
	D7	D6	D5	D4	D3	D2	D1	D0
Port P _n is a static logic-level low output port	0	X	0	0	0	0	0	0
Port P _n is a PWM output port; PWM duty cycle is 1/32	0	X	0	0	0	0	0	1
Port P _n is a PWM output port; PWM duty cycle is 2/32	0	X	0	0	0	0	1	0
Port P _n is a PWM output port; PWM duty cycle is 3/32	0	X	0	0	0	0	1	1
Port P _n is a PWM output port; PWM duty cycle is 4/32	0	X	0	0	0	1	0	0
...	...							
Port P _n is a PWM output port; PWM duty cycle is 30/32	0	X	0	1	1	1	1	0
Port P _n is a PWM output port; PWM duty cycle is 31/32	0	X	0	1	1	1	1	1
Port P _n is a static logic-level high output port	0	1	1	1	X	X	X	X

function to synchronize multiple MAX7302s that are operating from the same OSCIN, or to synchronize a single MAX7302's blink timing to an external event. Configure the \overline{RST} input to reset the internal timing counters used by PWM and blink by setting bit D1 of the device configuration register 0x26 (see Table 3).

The MAX7302 uses the internal oscillator by default. Configure port P2 using device configuration register 0x27 bit D2 (see Table 4) as an external clock source input, OSCIN, if the application requires a particular or more accurate timing for the PWM or blink functions. OSCIN only applies to PWM and blink; the MAX7302 always uses the internal oscillator for debouncing and bus timeout. OSCIN can range up to 1MHz. Use device configuration register 0x27 bit D3 (see Table 4) to configure port P3 as OSCOUT to output a MAX7302's clock. The MAX7302 buffers the clock output of either the internal oscillator OSC or the external clock source OSCIN, according to port D2's setup. Synchronize multiple MAX7302s without using an external clock source input by configuring one MAX7302 to generate

OSCOUT from its internal clock, and use this signal to drive the remaining MAX7302s' OSCIN.

A PWM period contains 32 cycles of the nominal 1kHz PWM clock (see Figure 6). Set ports individually to a PWM duty cycle between 0/32 and 31/32. For static logic-level low output, set the ports to 0/32 PWM, and for static logic-level high output, set the port register to 0111XXXX (see Table 9). The MAX7302 staggers the PWM timing of the 9-port outputs, in single or dual ports, by 1/8 of the PWM period. These phase shifts distribute the port-output switching points across the PWM period (see Figure 7). This staggering reduces the di/dt output-switching transient on the supply and also reduces the peak/mean current requirement.

All ports feature LED blink control. A global blink period of 1/8s, 1/4s, 1/2s, 1s, 2s, 4s, or 8s applies to all ports (see Table 10). Any port can blink during this period with a 1/16 to 15/16 duty cycle, adjustable in 1/16 increments (see Table 11). For PWM fan control, the MAX7302 can set the blink frequency to 32Hz.

SMBus/I²C Interfaced 9-Port, Level-Translating GPIO and LED Driver with CLA

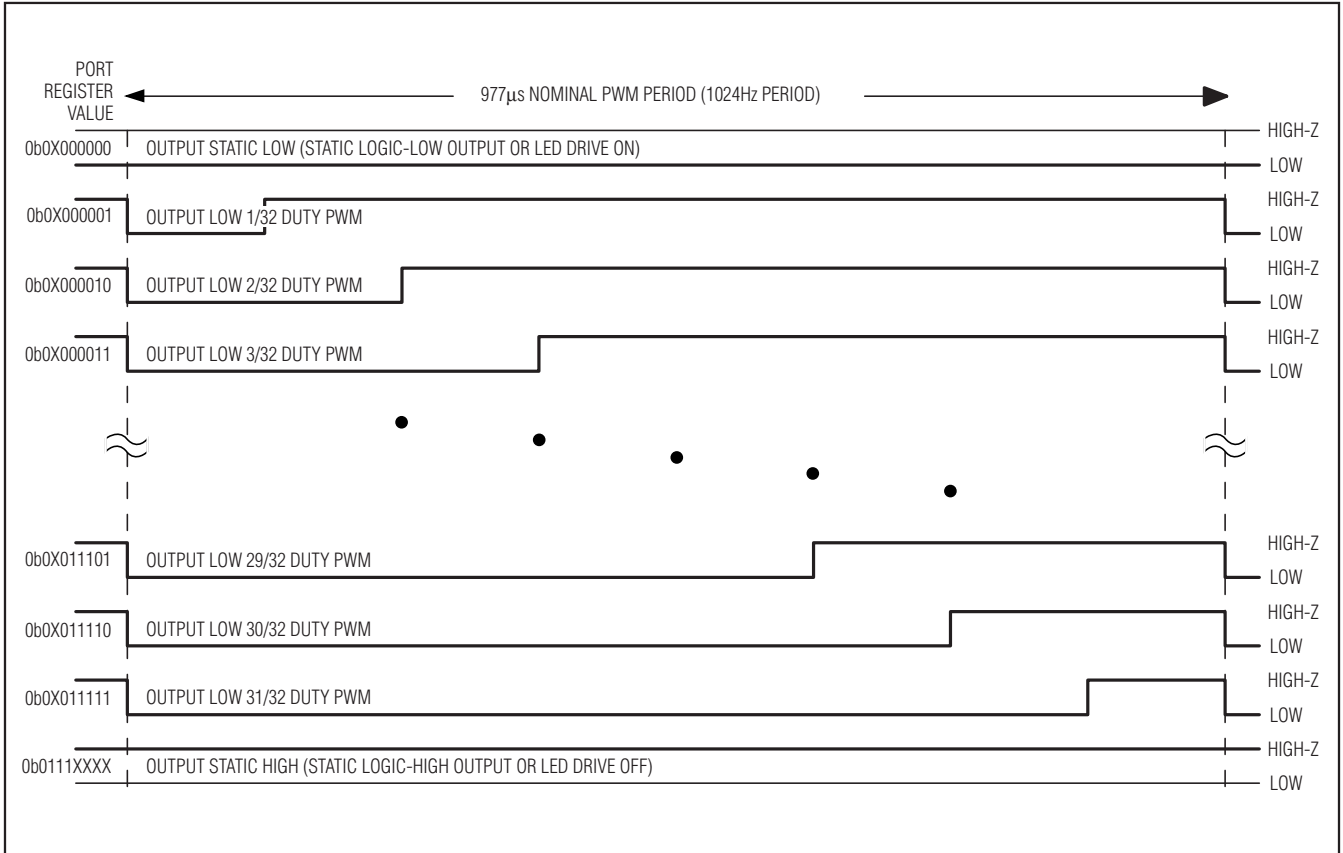

Figure 6. Static and PWM Port Output Waveforms

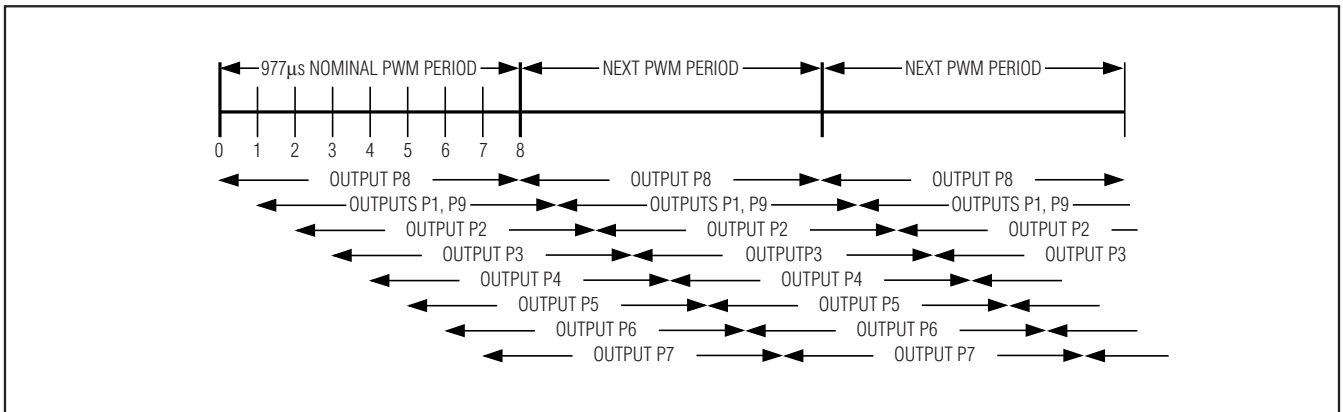

Figure 7. Staggered PWM Phasing Between Port Outputs

SMBus/I²C Interfaced 9-Port, Level-Translating GPIO and LED Driver with CLA

MAX7302

Table 10. Blink and PWM Frequencies

BLINK OR PWM SETTING	DEVICE CONFIGURATION REGISTER 0x26			BLINK OR PWM FREQUENCY (32kHz INTERNAL OSCILLATOR) (Hz)	BLINK OR PWM FREQUENCY (0 TO 1MHz EXTERNAL OSCILLATOR)
	BIT D4 BLINK2	BIT D3 BLINK1	BIT D2 BLINK0		
Blink period is 8s (0.125Hz)	0	0	0	0.125	OSCIN / 262,144
Blink period is 4s (0.25Hz)	0	0	1	0.25	OSCIN / 131,072
Blink period is 2s (0.5Hz)	0	1	0	0.5	OSCIN / 65,536
Blink period is 1s (1Hz)	0	1	1	1	OSCIN / 32,768
Blink period is a 1/2s (2Hz)	1	0	0	2	OSCIN / 16,384
Blink period is a 1/4s (4Hz)	1	0	1	4	OSCIN / 8192
Blink period is an 1/8s (8Hz)	1	1	0	8	OSCIN / 4096
Blink period is a 1/32s (32Hz)	1	1	1	32	OSCIN / 1024
PWM	X	X	X	1024	OSCIN / 32

Table 11. Blink Settings on Output Ports

PWM SETTINGS	REGISTER DATA							
	D7	D6	D5	D4	D3	D2	D1	D0
Port P_ is a static logic-level low output port	0	X	1	0	0	0	0	0
Port P_ is a PWM output port; PWM duty cycle is 1/16	0	X	1	0	0	0	0	1
Port P_ is a PWM output port; PWM duty cycle is 2/16	0	X	1	0	0	0	1	0
Port P_ is a PWM output port; PWM duty cycle is 3/16	0	X	1	0	0	1	0	0
...	...							
Port P_ is a PWM output port; PWM duty cycle is 14/16	0	X	1	0	1	1	1	0
Port P_ is a PWM output port; PWM duty cycle is 15/16	0	X	1	0	1	1	1	1
Port P_ is a static logic-level high output port (32/32)	0	1	1	1	X	X	X	X

Table 12. CLA0 (P2–P5) Configuration Register Setting (0x28)

FUNCTION	REGISTER BIT					
	D5	D4	D3	D2	D1	D0
XOR noninverted	0	1	X	0	X	0
XOR P3 inverted				1		0
XOR P2 inverted				0		1
XOR both ports inverted				1		1
3 input AND/OR all noninverted	1	0	1	0	1	0
3 input AND/OR P2 inverted		0		0		1
3 input AND/OR P3 inverted		0		1		0
3 input AND/OR P4 inverted		0		1		1
3 input AND/OR P2 and P3 inverted		1		0		0
3 input AND/OR P2 and P4 inverted		1		0		1
3 input AND/OR P3 and P4 inverted		1		1		0
3 input AND/OR all inverted		1		1		1

SMBus/I²C Interfaced 9-Port, Level-Translating GPIO and LED Driver with CLA

Table 12. CLA0 (P2–P5) Configuration Register Setting (0x28) (continued)

FUNCTION	REGISTER BIT					
	D5	D4	D3	D2	D1	D0
2 input AND/OR P2 and P3 noninverted	0	X	1	0	1	0
2 input AND/OR P2 and P3 inverted				1		0
2 input AND/OR P2 inverted and P3				0		1
2 input AND/OR P2 and P3 both inverted				1		1
2 input AND/OR P2 and P4 noninverted	1	0	0	X	1	0
2 input AND/OR P2 and P4 inverted		1				0
2 input AND/OR P2 inverted and P4		0				1
2 input AND/OR P2 and P4 both inverted		1				1
2 input AND/OR P3 and P4 noninverted	1	0	1	0	0	X
2 input AND/OR P3 and P4 inverted		0		1		
2 input AND/OR P3 inverted and P4		1		0		
2 input AND/OR P3 and P4 both inverted		1		1		

Table 13. Output P5 Configuration

BIT	LOGIC LEVEL	FUNCTION
D7	0	Output not cascaded to CLA1
	1	Output cascaded to CLA1
D6	0	Output noninverted
	1	Output inverted

Table 14. CLA1 (P6–P9) Configuration Register Setting (0x29)

FUNCTION	REGISTER BIT					
	D5	D4	D3	D2	D1	D0
XOR noninverted	0	1	X	0	X	0
XOR P7 inverted				1		0
XOR P6 inverted				0		1
XOR both ports inverted				1		1
3 input AND/OR all noninverted	1	0	1	0	1	0
3 input AND/OR P6 inverted		0		0		1
3 input AND/OR P7 inverted		0		1		0
3 input AND/OR P8 inverted		0		1		1
3 input AND/OR P6 and P7 inverted		1		0		0
3 input AND/OR P6 and P8 inverted		1		0		1
3 input AND/OR P7 and P8 inverted		1		1		0
3 input AND/OR all inverted		1		1		1
2 input AND/OR P6 and P7 noninverted	0	X	1	0	1	0
2 input AND/OR P6 and P7 inverted				1		0
2 input AND/OR P6 inverted and P7				0		1
2 input AND/OR P6 and P7 both inverted				1		1

SMBus/I²C Interfaced 9-Port, Level-Translating GPIO and LED Driver with CLA

MAX7302

Table 14. CLA1 (P6–P9) Configuration Register Setting (0x29) (continued)

FUNCTION	REGISTER BIT					
	D5	D4	D3	D2	D1	D0
2 input AND/OR P6 and P8 noninverted	1	0	0	X	1	0
2 input AND/OR P6 and P8 inverted		1				0
2 input AND/OR P6 inverted and P8		0				1
2 input AND/OR P6 and P8 both inverted		1				1
2 input AND/OR P7 and P8 noninverted	1	0	1	0	0	X
2 input AND/OR P7 and P8 inverted		0		1		
2 input AND/OR P7 inverted and P8		1		0		
2 input AND/OR P7 and P8 both inverted		1		1		

Table 15. Output P9 and Cascade P5 Input Configuration

BIT	LOGIC LEVEL	FUNCTION
D7	0	Cascade input noninverted
	1	Cascade input inverted
D6	0	Output noninverted
	1	Output inverted

Table 17. Configurable Logic-Array Lock Register (0x71)

REGISTER	REGISTER DATA		
	D7–D2	D1	D0
CLA0 and CLA1 configurable logic lock		CLA1	CLA0
CLA0 is not locked	—	X	0
CLA0 is locked	—	X	1
CLA1 is not locked	—	0	X
CLA1 is locked	—	1	X

Table 16. Configurable Logic-Array Enable Register (0x70)

REGISTER	REGISTER DATA		
	D7–D2	D1	D0
CLA0 and CLA1 configurable logic enable		CLA1	CLA0
Ports P2–P5 are GPIO ports	—	X	0
Ports P2–P5 are configurable logic CLA0	—	X	1
Ports P6–P9 are GPIO ports	—	0	X
Ports P6–P9 are configurable logic CLA1	—	1	X

SMBus/I²C Interfaced 9-Port, Level-Translating GPIO and LED Driver with CLA

Table 18. Port I/O Registers (I/O Port 5 and 9 Configured as CLA Outputs, Registers 0x05 and 0x09)

REGISTER BIT	DESCRIPTION	VALUE	FUNCTION
D7	Don't care	x	Don't care.
D6	Port supply reference	0	Refers inputs to the VL supply voltage; sets outputs to open drain.
		1	Refers inputs to the V _{DD} supply voltage; sets outputs to push-pull.
D5	Transition interrupt enable	0	Disables the transition interrupt.
		1	Enables the transition interrupt.
D4	Transition detection bit 1	0	Detects the next transition on the port input.
D3	Transition detection bit 0	0	Detects the next transition on the port input.
D2	Debounce	0	Disables debouncing of the input port.
		1	Enables debouncing of the input port.
D1	Port transition state	0	No transition has occurred since the last port read.
		1	A transition has occurred since the last port read.
D0	Port status	0	Port input is logic-low.
		1	Port input is logic-high.

Configurable Logic Array (CLA)

The CLA configures groups of four ports as either a combinational logic gate up to three inputs, or a two input exclusive OR/NOR gate (see Tables 12-15). Eight-port dual groups can be cascaded to form a two-level gate with the intermediate term brought out as an output or not, as desired. If fewer than three gate inputs are needed, the unused CLA input(s) (which can be any combination of the three CLA inputs) remain available as independent GPIO ports (see Figure 8). Use the configurable logic-array enable register (see Table 16) to enable ports as CLAs. Use the configurable logic-array lock register (see Table 17) to permanently lock in any logic-array combination of CLAs until the next power cycle. Setting D0 and D1 to logic-high in the configurable logic-array lock register locks the corresponding bit position in the configurable logic-array enable register. Additionally, the appropriate CLA_ register (addresses 0x28 and 0x29) cannot be changed.

The configurable logic-array lock register is unlocked on power-up, or by RST when configured by the

RSTPOR bit in the configure register. Each lock bit can only be written to once per power cycle.

A CLA's input(s) and output can be read through the serial interface like a normal input port. The MAX7302 creates a gate that provides an independent real-time logic function, and every node of it can be examined through the I²C interface with optional debounce and transition detection.

Setting bits D0 and D1 to logic-high enables the CLA functionality and sets ports P5 and P9 as CLA outputs (see Table 16). When in CLA mode, the port I/O register data is interpreted differently for CLA output ports (see Table 18). Bit D7 that normally selects the port direction is ignored because either port P5 or P9 is always an output. Bit D6 sets both the CLA output type (push-pull or open drain) and the logic threshold for reading the CLA output status back through the I²C interface. The other bits set the readback options, such as debounce and transition detection interrupt.

SMBus/I²C Interfaced 9-Port, Level-Translating GPIO and LED Driver with CLA

MAX7302

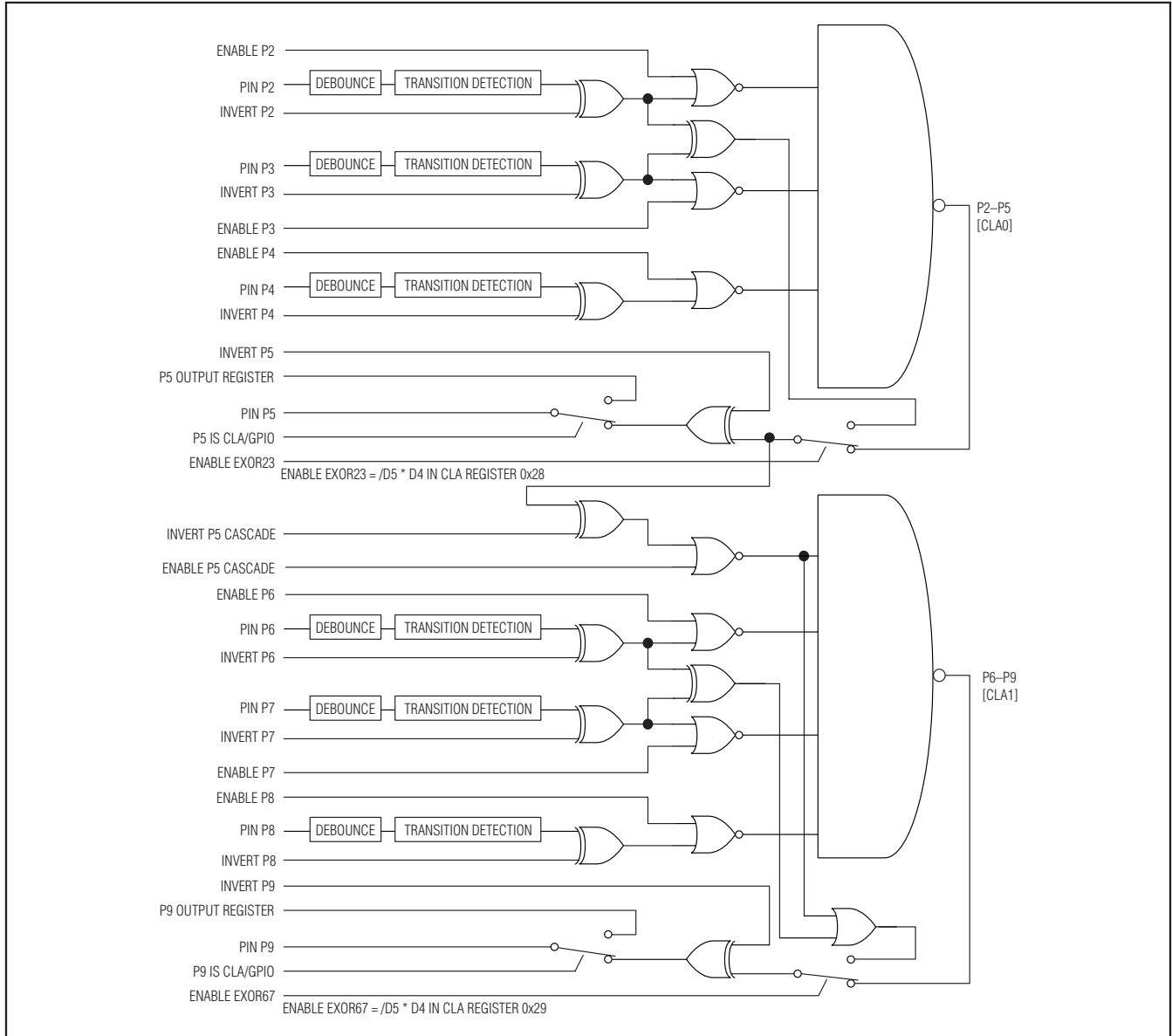

Figure 8. Configurable Logic-Array Structure

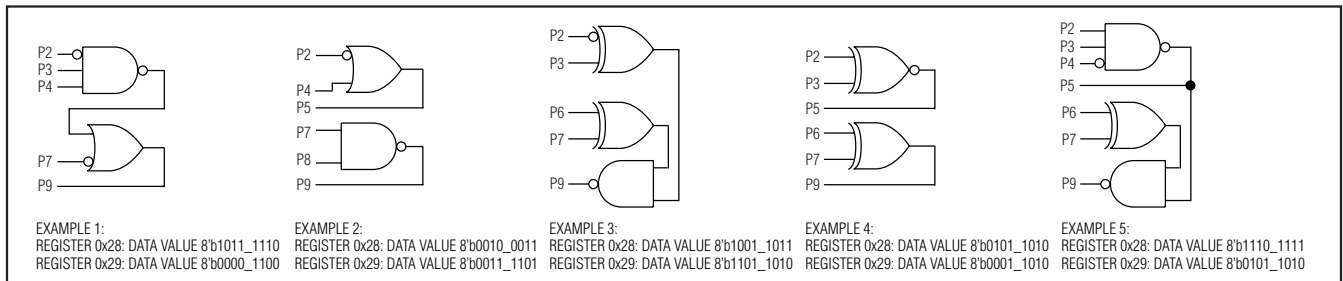

Figure 9. Configurable Logic Examples

SMBus/I²C Interfaced 9-Port, Level-Translating GPIO and LED Driver with CLA

Serial Interface

Serial Addressing

The MAX7302 operates as a slave that sends and receives data through an I²C-compatible, 2-wire interface. The interface uses a serial-data line (SDA) and a serial-clock line (SCL) to achieve bidirectional communication between master(s) and slave(s). A master (typically a microcontroller) initiates all data transfers to and from the MAX7302 and generates the SCL clock that synchronizes the data transfer (see Figure 10).

The MAX7302 SDA line operates as both an input and an open-drain output. A 4.7kΩ (typ) pullup resistor is required on SDA. The MAX7302 SCL line operates only as an input. A 4.7kΩ (typ) pullup resistor is required on SCL if there are multiple masters on the 2-wire interface, or if the master in a single-master system has an open-drain SCL output.

Each transmission consists of a START condition (see Figure 11) sent by a master, followed by the MAX7302 7-bit slave address plus R/W bit, a register address byte, one or more data bytes, and finally a STOP condition (see Figure 11).

START and STOP Conditions

Both SCL and SDA remain high when the interface is not busy. A master signals the beginning of a transmission with a START (S) condition by transitioning SDA from high to low while SCL is high. When the master has finished communicating with the slave, it issues a STOP (P) condition by transitioning SDA from low to high while SCL is high. The bus is then free for another transmission (see Figure 11).

Bit Transfer

One data bit is transferred during each clock pulse. The data on SDA must remain stable while SCL is high (see Figure 12).

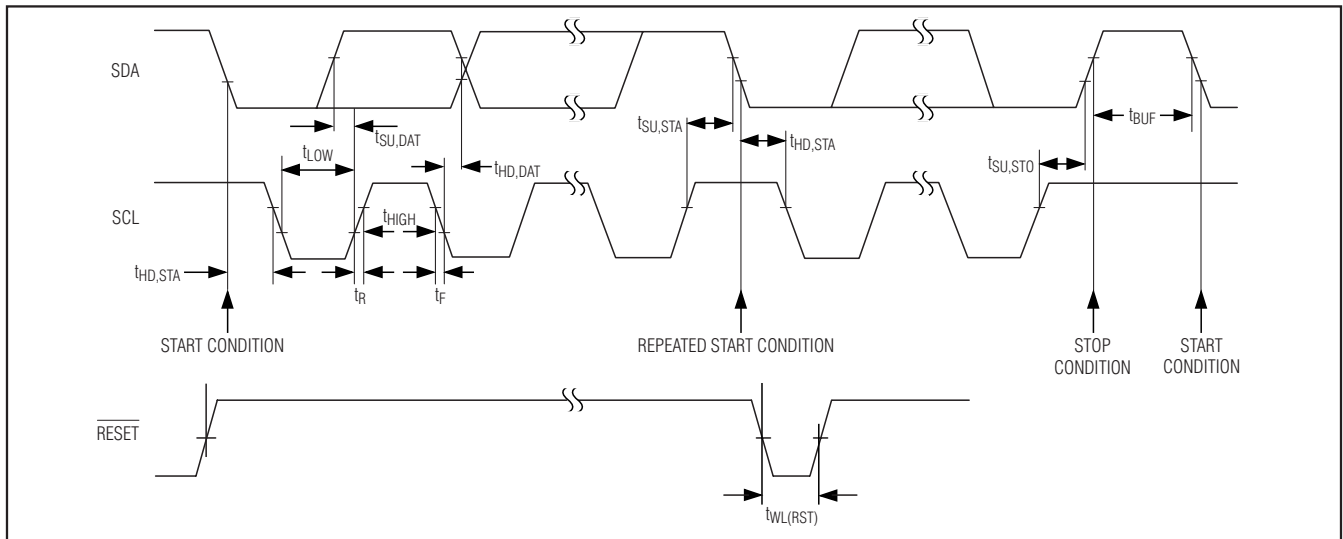

Figure 10. 2-Wire Serial Interface Timing Details

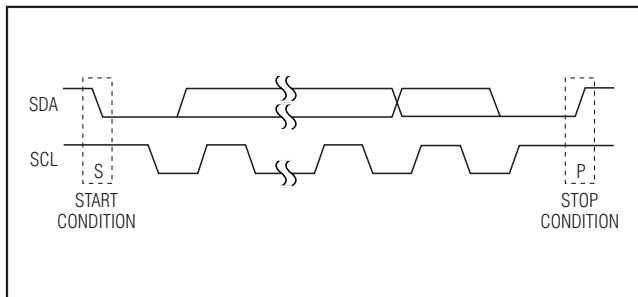

Figure 11. START and STOP Conditions

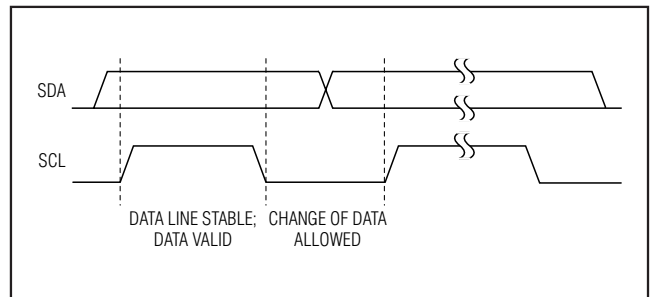

Figure 12. Bit Transfer

SMBus/I²C Interfaced 9-Port, Level-Translating GPIO and LED Driver with CLA

Acknowledge

The acknowledge bit is a clocked 9th bit that the recipient uses to handshake receipt of each byte of data (see Figure 13). Thus, each effectively transferred byte requires 9 bits. The master generates the 9th clock pulse, and the recipient pulls down SDA during the acknowledge clock pulse, such that the SDA line is stable low during the high period of the clock pulse. When the master is transmitting to the MAX7302, the MAX7302 generates the acknowledge bit because the MAX7302 is the recipient. When the MAX7302 is transmitting to the master, the master generates the acknowledge bit because the master is the recipient.

The Slave Address

The MAX7302 has a 7-bit long slave address (Figure 14). The 8th bit following the 7-bit slave address is the R/W bit. Set R/W bit low for a write command and high for a read command.

The first 5 bits of the MAX7302 slave address (A6–A2) are always 1, 0, 0, 1, and 1. Slave address bit A1, A0 is selected by the address input AD0. AD0 can be connected to GND, VDD, SDA, or SCL. The MAX7302 has four possible slave addresses (see Table 5), and therefore, a maximum of four MAX7302 devices can be controlled independently from the same interface.

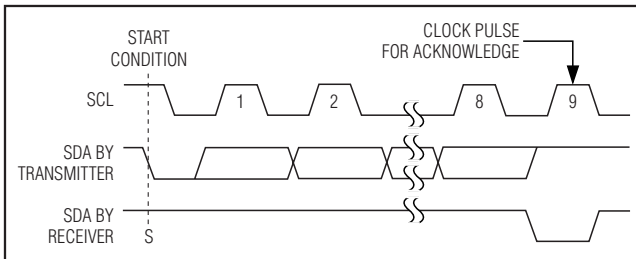

Figure 13. Acknowledge

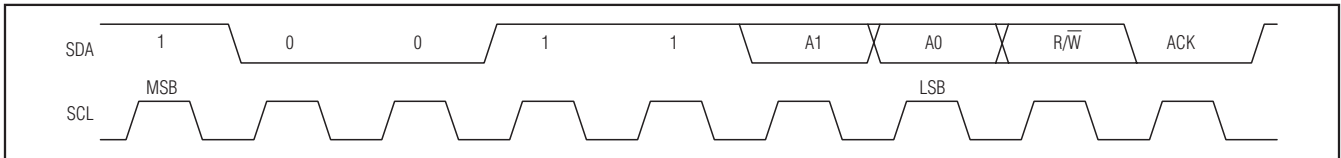

Figure 14. Slave Address

Message Format for Writing to the MAX7302

A write to the MAX7302 comprises the transmission of the MAX7302's slave address with the R/W bit set to zero, followed by at least 1 byte of information (see Figure 16). The first byte of information is the command byte. The command byte determines which register of the MAX7302 is to be written to by the next byte, if received. If a STOP condition is detected after the command byte is received, the MAX7302 takes no further action beyond storing the command byte (see Figure 15).

Any bytes received after the command byte are data bytes. The first data byte goes into the internal register of the MAX7302 selected by the command byte (see Figure 16). If multiple data bytes are transmitted before a STOP condition is detected, these bytes are generally stored in subsequent MAX7302 internal registers because the command byte address autoincrements (see Table 3).

Message Format for Reading

The MAX7302 is read using the MAX7302's internally stored command byte as an address pointer the same way the stored command byte is used as an address pointer for a write. The pointer autoincrements after each data byte is read using the same rules as for a write. Thus, a read is initiated by first configuring the MAX7302's command byte by performing a write (Figure 15). The master can now read n consecutive bytes from the MAX7302 with the first data byte being read from the register addressed by the initialized command byte (see Figure 17). When performing read-after-write verification, remember to reset the command byte's address because the stored command byte address has been autoincremented after the write.

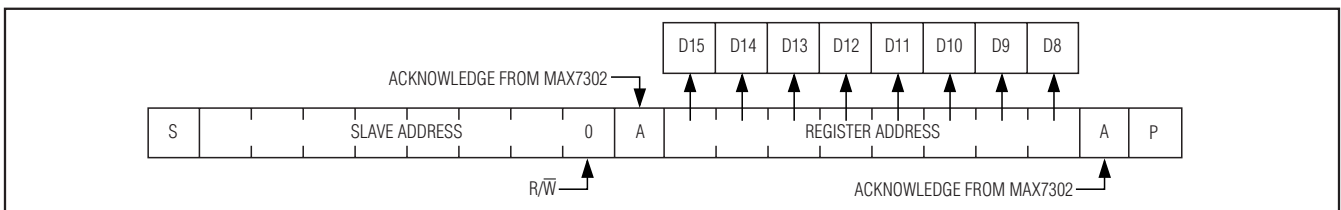

Figure 15. Register Address Received

SMBus/I²C Interfaced 9-Port, Level-Translating GPIO and LED Driver with CLA

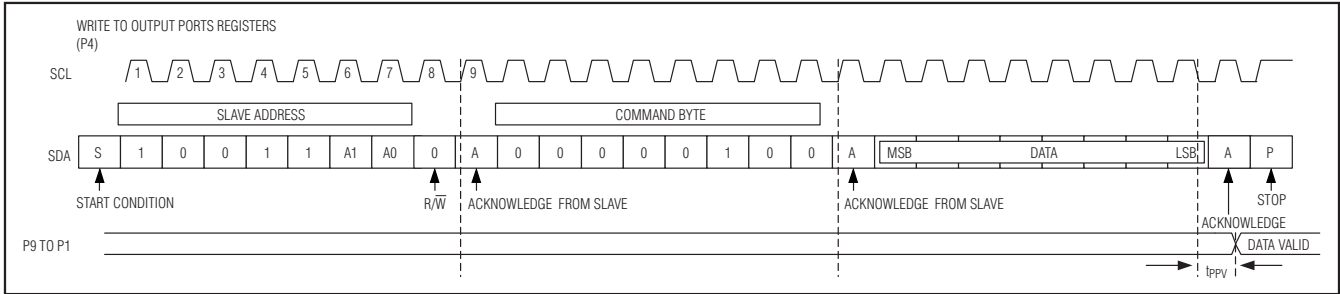

Figure 16. Write to Output Port Registers

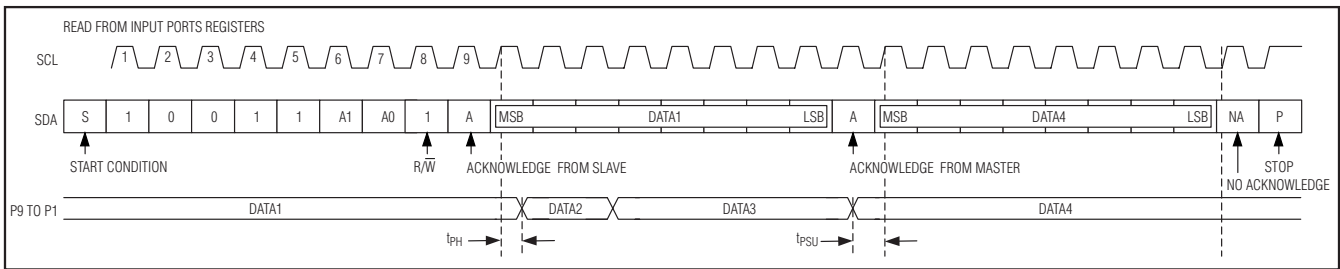

Figure 17. Read from Input Port Registers

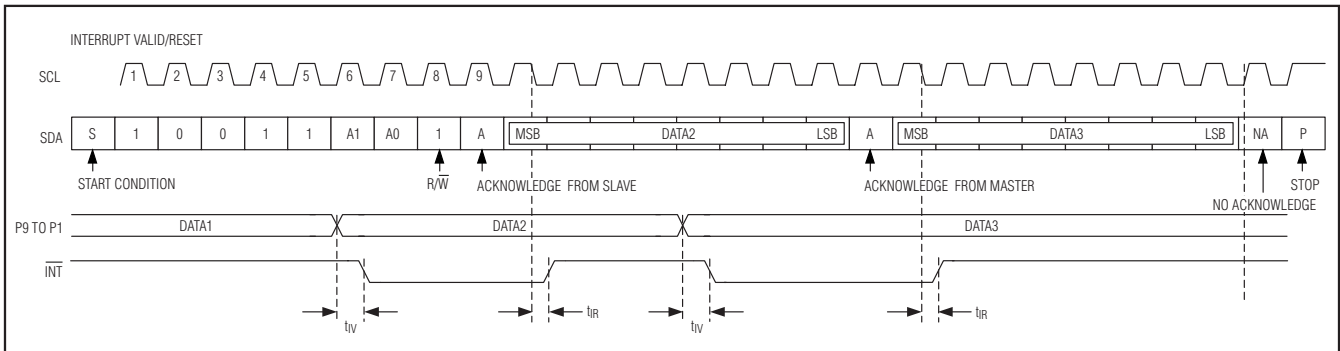

Figure 18. Interrupt and Reset Timing

Operation with Multiple Masters

If the MAX7302 is operated on a 2-wire interface with multiple masters, a master reading the MAX7302 should use a repeated start between the write that sets the MAX7302's address pointer, and the read(s) that takes the data from the location(s). This is because it is possible for master 2 to take over the bus after master 1 has set up the MAX7302's address pointer, but before master 1 has read the data. If master 2 subsequently changes the MAX7302's address pointer, then master 1's delayed read can be from an unexpected location.

Bus Timeout

Clear device configuration register 0x27 bit D7 to enable the bus timeout function (see Table 4), or set it to disable the bus timeout function. Enabling the timeout feature resets the MAX7302 serial-bus interface when SCL stops either high or low during a read or write. If either SCL or SDA is low for more than nominally 31ms after the start of a valid serial transfer, the interface resets itself and sets up SDA as an input. The MAX7302 then waits for another START condition.

SMBus/I²C Interfaced 9-Port, Level-Translating GPIO and LED Driver with CLA

MAX7302

Applications Information

Hot Insertion

Serial interfaces SDA, SCL, and AD0 remain high impedance with up to 6V asserted on them when the MAX7302 is powered down ($V_{DD} = 0V$) independent of the voltages on the port supply V_{LA} . When $V_{DD} = 0V$, or if V_{DD} falls below the MAX7302's reset threshold, all I/O ports become high impedance. The ports remain high impedance to signals between 0V and the port supply V_{LA} . If a signal outside this range is applied to a port, the port's protection diodes clamp the input signal to V_{LA} or 0V, as appropriate. If supply V_{LA} is lower than the input signal, the port pulls up V_{LA} and the protection diode effectively powers any load on V_{LA} from the input signal. This behavior is safe if the current through each protection diode is limited to 10mA.

If it is important that I/O ports remain high impedance when all the supplies are powered down, including the port supply V_{LA} , then ensure that there is no direct or parasitic path for MAX7302 input signals to drive current into either the regulator providing V_{LA} or other circuits powered from V_{LA} . One simple way to achieve this is with a series small-signal Schottky diode, such as the BAT54, between the port supply and the V_{LA} input.

Output Level Translation

The open-drain output configuration of the ports allows them to level translate the outputs to lower (but not higher) voltages than the V_{LA} supply. An external pullup resistor converts the high-impedance, logic-high condition to a positive voltage level. Connect the resistor to any voltage up to V_{LA} . For interfacing CMOS inputs, a pullup resistor value of 220k Ω is a good starting point. Use a lower resistance to improve noise immunity, in applications where power consumption is less critical, or where a faster rise time is needed for a given capacitive load.

Driving LED Loads

When driving LEDs, use a resistor in series with the LED to limit the LED current to no more than 25mA. Choose the resistor value according to the following formula:

$$R_{LED} = (V_{SUPPLY} - V_{LED} - V_{OL}) / I_{LED}$$

where:

R_{LED} is the resistance of the resistor in series with the LED (Ω)

V_{SUPPLY} is the supply voltage used to drive the LED (V)

V_{LED} is the forward voltage of the LED (V)

V_{OL} is the output low voltage of the MAX7302 when sinking I_{LED} (V)

I_{LED} is the desired operating current of the LED (A).

For example, to operate a 2.2V red LED at 20mA from a 5V supply, $R_{LED} = (5 - 2.2 - 0.8) / 0.020 = 100\Omega$.

Driving Load Currents Higher than 25mA

The MAX7302 can sink current from loads drawing more than 25mA by sharing the load across multiple ports configured as open-drain outputs. Use at least one output per 25mA of load current; for example, drive a 90mA white LED with four ports.

The register structure of the MAX7302 allows only one port to be manipulated at a time. Do not connect ports directly in parallel because multiple ports cannot be switched high or low at the same time, which is necessary to share a load safely. Multiple ports can drive high-current LEDs because each port can use its own external current-limiting resistor to set that port's current through the LED.

The exceptions to this paralleling rule are the four ports, P2–P5, and the four ports, P6–P9. These groups of four ports can be programmed simultaneously through the pseudoregisters 0x3C and 0x3D, respectively. A write access to 0x3C writes the same data to registers 0x02 through 0x05. A write access to 0x3D writes the same data to registers 0x06 through 0x09. Either of these groups of four ports can be paralleled to drive a load up to 100mA.

Power-Supply Considerations

The MAX7302 operates with a V_{DD} power-supply voltage of 1.62V to 3.6V. Bypass V_{DD} to GND with a 0.047 μ F capacitor as close as possible to the device. The port supply V_{LA} is connected to a supply voltage between 1.62V to 5.5V and bypassed with a 0.1 μ F capacitor as close as possible to the device. The V_{DD} supply and port supply are independent and can be connected to different voltages or the same supply as required.

Power supplies V_{DD} and V_{LA} can be sequenced in either order or together.

SMBus/I²C Interfaced 9-Port, Level-Translating GPIO and LED Driver with CLA

Pin Configurations

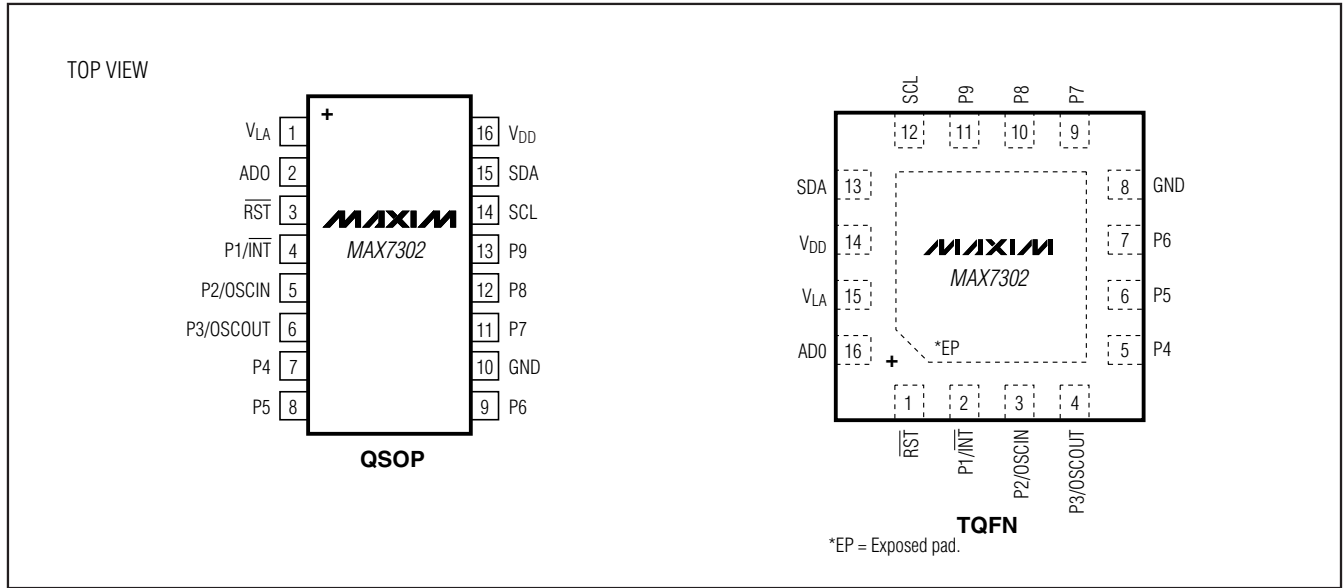

Chip Information

PROCESS: BiCMOS

SMBus/I²C Interfaced 9-Port, Level-Translating GPIO and LED Driver with CLA

Package Information

(The package drawing(s) in this data sheet may not reflect the most current specifications. For the latest package outline information, go to www.maxim-ic.com/packages.)

MAX7302

QSOP-EPS

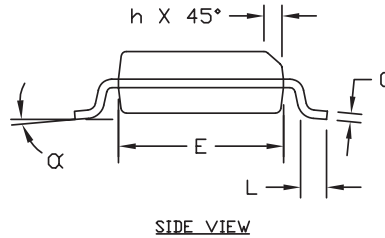
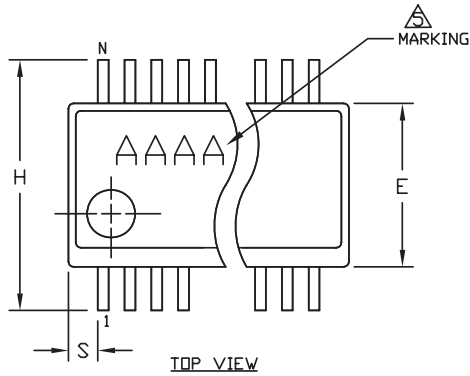

DIM	INCHES		MILLIMETERS	
	MIN	MAX	MIN	MAX
A	.053	.069	1.35	1.75
A1	.004	.010	.102	.254
A2	.049	.065	1.245	1.651
B	.008	.012	0.20	0.30
C	.0075	.0098	0.191	0.249
D	SEE VARIATIONS			
E	.150	.157	3.81	3.99
e	.025 BSC		0.635 BSC	
H	.230	.244	5.84	6.20
h	.010	.016	0.25	0.41
L	.016	.035	0.41	0.89
N	SEE VARIATIONS			
α	0°	8°	0°	8°

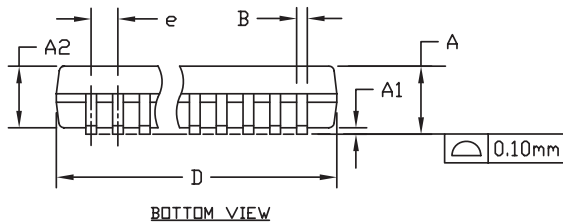

VARIATIONS:

DIM	INCHES		MILLIMETERS		N	PKG CODES
	MIN.	MAX.	MIN.	MAX.		
D	.189	.196	4.80	4.98	16	E16-1, E16M-1, E16-3F, E16-4, E16-5, E16-6, E16-8F
S	.0020	.0070	0.05	0.18		
D	.337	.344	8.56	8.74	20	E20-1, E20-2
S	.0500	.0550	1.270	1.397		
D	.337	.344	8.56	8.74	24	E24-1, E24-2, E24-3F
S	.0250	.0300	0.635	0.762		
D	.386	.393	9.80	9.98	28	E28-1, E28M-1, E28-2
S	.0250	.0300	0.635	0.762		

NOTES:

1. D & E DO NOT INCLUDE MOLD FLASH OR PROTRUSIONS.
2. MOLD FLASH OR PROTRUSIONS NOT TO EXCEED .006" PER SIDE.
3. CONTROLLING DIMENSIONS: INCHES.
4. MEETS JEDEC MO137.
5. MARKING SHOWN IS FOR PKG. ORIENTATION ONLY.
6. ALL DIMENSIONS APPLY TO BOTH LEADED (-) AND PbFREE (+) PKG. CODES.

-DRAWING NOT TO SCALE-

MAXIM

TITLE:
PACKAGE OUTLINE
QSOP .150", .025" LEAD PITCH

APPROVAL	DOCUMENT CONTROL NO. 21-0055	REV. G	1/1
----------	---------------------------------	-----------	-----

SMBus/I²C Interfaced 9-Port, Level-Translating GPIO and LED Driver with CLA

Package Information (continued)

(The package drawing(s) in this data sheet may not reflect the most current specifications. For the latest package outline information, go to www.maxim-ic.com/packages.)

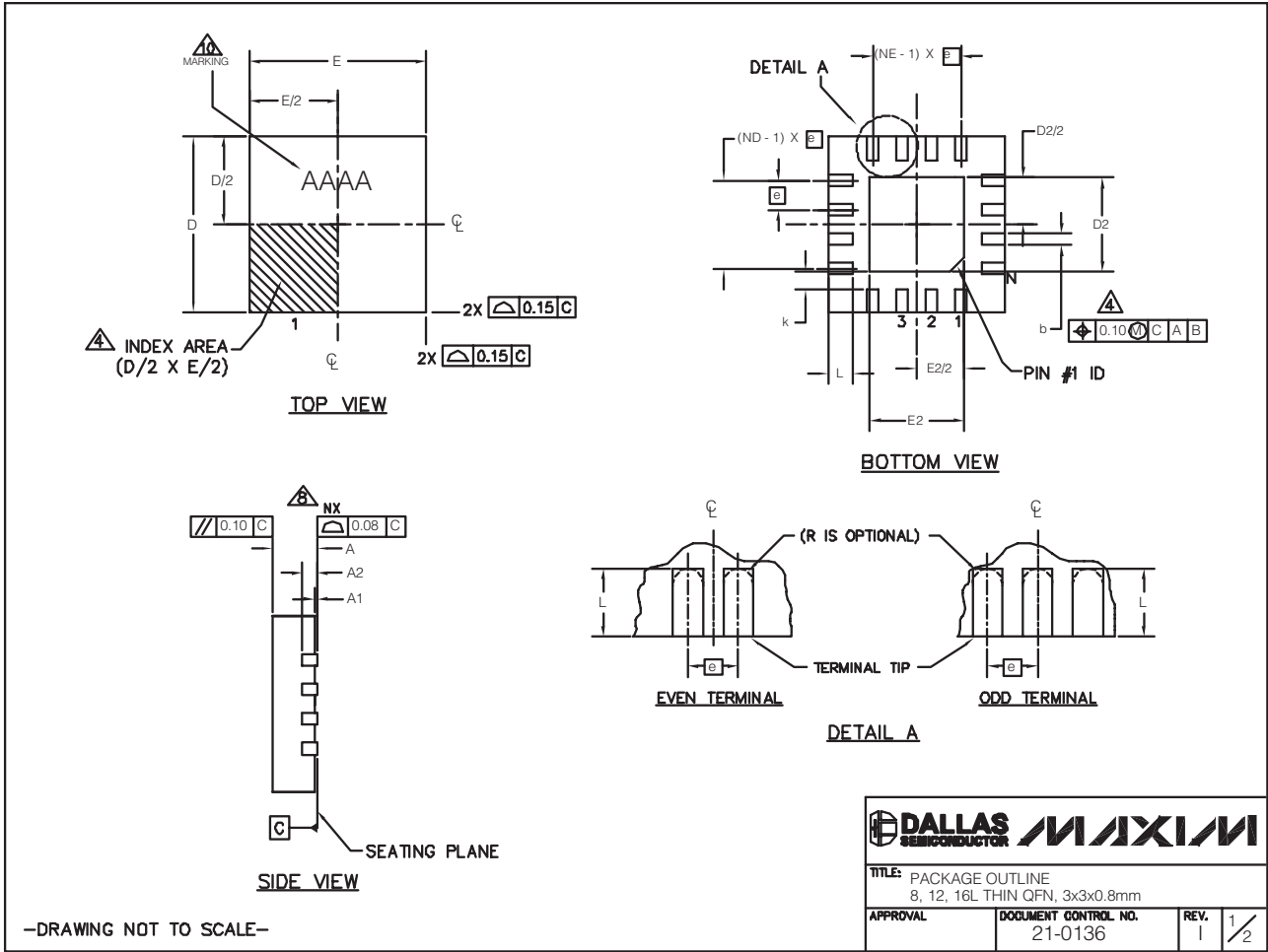

-DRAWING NOT TO SCALE-

TITLE: PACKAGE OUTLINE 8, 12, 16L THIN QFN, 3x3x0.8mm		
APPROVAL	DOCUMENT CONTROL NO. 21-0136	REV. 1 1/2

SMBus/I²C Interfaced 9-Port, Level-Translating GPIO and LED Driver with CLA

Package Information (continued)

(The package drawing(s) in this data sheet may not reflect the most current specifications. For the latest package outline information, go to www.maxim-ic.com/packages.)

MAX7302

PKG	8L 3x3			12L 3x3			16L 3x3		
REF.	MIN.	NOM.	MAX.	MIN.	NOM.	MAX.	MIN.	NOM.	MAX.
A	0.70	0.75	0.80	0.70	0.75	0.80	0.70	0.75	0.80
b	0.25	0.30	0.35	0.20	0.25	0.30	0.20	0.25	0.30
D	2.90	3.00	3.10	2.90	3.00	3.10	2.90	3.00	3.10
E	2.90	3.00	3.10	2.90	3.00	3.10	2.90	3.00	3.10
e	0.65 BSC.			0.50 BSC.			0.50 BSC.		
L	0.35	0.55	0.75	0.45	0.55	0.65	0.30	0.40	0.50
N	8			12			16		
ND	2			3			4		
NE	2			3			4		
A1	0	0.02	0.05	0	0.02	0.05	0	0.02	0.05
A2	0.20 REF			0.20 REF			0.20 REF		
k	0.25	-	-	0.25	-	-	0.25	-	-

EXPOSED PAD VARIATIONS								
PKG CODES	D2			E2			PIN ID	JEDEC
	MIN.	NOM.	MAX.	MIN.	NOM.	MAX.		
TQ833-1	0.25	0.70	1.25	0.25	0.70	1.25	0.35 x 45°	WEEC
T1233-1	0.95	1.10	1.25	0.95	1.10	1.25	0.35 x 45°	WEED-1
T1233-3	0.95	1.10	1.25	0.95	1.10	1.25	0.35 x 45°	WEED-1
T1233-4	0.95	1.10	1.25	0.95	1.10	1.25	0.35 x 45°	WEED-1
T1633-2	0.95	1.10	1.25	0.95	1.10	1.25	0.35 x 45°	WEED-2
T1633F-3	0.65	0.80	0.95	0.65	0.80	0.95	0.225 x 45°	WEED-2
T1633FH-3	0.65	0.80	0.95	0.65	0.80	0.95	0.225 x 45°	WEED-2
T1633-4	0.95	1.10	1.25	0.95	1.10	1.25	0.35 x 45°	WEED-2
T1633-5	0.95	1.10	1.25	0.95	1.10	1.25	0.35 x 45°	WEED-2

NOTES:

- DIMENSIONING & TOLERANCING CONFORM TO ASME Y14.5M-1994.
- ALL DIMENSIONS ARE IN MILLIMETERS. ANGLES ARE IN DEGREES.
- N IS THE TOTAL NUMBER OF TERMINALS.
- THE TERMINAL #1 IDENTIFIER AND TERMINAL NUMBERING CONVENTION SHALL CONFORM TO JESD 95-1 SPP-012. DETAILS OF TERMINAL #1 IDENTIFIER ARE OPTIONAL, BUT MUST BE LOCATED WITHIN THE ZONE INDICATED. THE TERMINAL #1 IDENTIFIER MAY BE EITHER A MOLD OR MARKED FEATURE.
- DIMENSION b APPLIES TO METALLIZED TERMINAL AND IS MEASURED BETWEEN 0.20 mm AND 0.25 mm FROM TERMINAL TIP.
- ND AND NE REFER TO THE NUMBER OF TERMINALS ON EACH D AND E SIDE RESPECTIVELY.
- DEPOPULATION IS POSSIBLE IN A SYMMETRICAL FASHION.
- COPLANARITY APPLIES TO THE EXPOSED HEAT SINK SLUG AS WELL AS THE TERMINALS.
- DRAWING CONFORMS TO JEDEC MO220 REVISION C.
- MARKING IS FOR PACKAGE ORIENTATION REFERENCE ONLY.
- NUMBER OF LEADS SHOWN ARE FOR REFERENCE ONLY.
- WARPAGE NOT TO EXCEED 0.10mm.

-DRAWING NOT TO SCALE-

		
TITLE: PACKAGE OUTLINE 8, 12, 16L THIN QFN, 3x3x0.8mm		
APPROVAL	DOCUMENT CONTROL NO. 21-0136	REV. 1
		2/2

SMBus/I²C Interfaced 9-Port, Level-Translating GPIO and LED Driver with CLA

Revision History

REVISION NUMBER	REVISION DATE	DESCRIPTION	PAGES CHANGED
0	7/07	Initial release	—
1	12/07	Corrected configuration 26 errors in Tables 1 and 2 and updated package outline for 16-pin QSOP.	8, 27

Maxim cannot assume responsibility for use of any circuitry other than circuitry entirely embodied in a Maxim product. No circuit patent licenses are implied. Maxim reserves the right to change the circuitry and specifications without notice at any time.

30 **Maxim Integrated Products, 120 San Gabriel Drive, Sunnyvale, CA 94086 408-737-7600**

© 2007 Maxim Integrated Products

MAXIM is a registered trademark of Maxim Integrated Products, Inc.