



Power Bridge Rectifiers

SKB 26

Features

- Square plastic case with isolated metal base plate and wire leads
- Ideal for printed circuit boards
- Blocking voltage up to 1600 V
- High surge currents
- Notch moulded in casing for easy polarity identification
- Easy chassis mounting

Typical Applications*

- Single phase rectifiers for power supplies
- Input rectifiers for variable frequency drives
- Rectifiers for DC motor field supplies
- Battery charge rectifiers
- Recommended snubber network:
RC: 0.1 μ F, 50 Ω ($P_R = 1$ W)

1) Soldered directly onto a p.c.b. of 100 x 160 mm with tinned tracking of min. 2.5 mm

2) Mounted on a painted metal sheet of min. 250 x 250 x 1 mm

V_{RSM}, V_{RRM} V	V_{VRMS} V	$I_D = 18$ A ($T_c = 75$ °C) Types	C_{max} μ F	R_{min} Ω
200	60	SKB 26/02		0,15
400	125	SKB 26/04		0,3
600	185	SKB 26/06		0,4
800	250	SKB 26/08		0,5
1000	310	SKB 26/10		0,65
1200	380	SKB 26/12		0,75
1400	440	SKB 26/14		0,9
1600	500	SKB 26/16		1

Symbol	Conditions	Values	Units
I_D	$T_a = 45$ °C, isolated ¹⁾	3,5	A
	$T_a = 45$ °C, chassis ²⁾	10	A
I_{DCL}	$T_a = 45$ °C, isolated ¹⁾	3	A
	$T_a = 45$ °C, chassis ²⁾	9,5	A
	$T_a = 45$ °C, P1A/120	14	A
I_{FSM}	$T_{vj} = 25$ °C, 10 ms	370	A
	$T_{vj} = 150$ °C, 10 ms	320	A
i^2t	$T_{vj} = 25$ °C, 8,3 ... 10 ms	680	A ² s
	$T_{vj} = 150$ °C, 8,3 ... 10 ms	500	A ² s
V_F	$T_{vj} = 25$ °C, $I_F = 150$ A	max. 2,2	V
$V_{(TO)}$	$T_{vj} = 150$ °C	max. 0,85	V
r_T	$T_{vj} = 150$ °C	max. 12	m Ω
I_{RD}	$T_{vj} = 25$ °C, $V_{RD} = V_{RRM}$	300	μ A
	$T_{vj} = 150$ °C, $V_{RD} = V_{RRM} \geq V$		μ A
I_{RD}	$T_{vj} = 150$ °C, $V_{RD} = V_{RRM}$	5	mA
	$T_{vj} = 150$ °C, $V_{RD} = V_{RRM} \geq V$		mA
t_{rr}	$T_{vj} = 25$ °C	10	μ s
f_G		2000	Hz
$R_{th(j-a)}$	isolated ¹⁾	15	K/W
	chassis ²⁾	4,7	K/W
$R_{th(j-c)}$	total	1,9	K/W
$R_{th(c-s)}$	total	0,15	K/W
T_{vj}		- 40 ... + 150	°C
T_{stg}		- 55 ... + 150	°C
V_{isol}	a. c. 50 ... 60 Hz; r.m.s.; 1 s / 1 min.	3000 / 2500	V~
M_s	to heatsink	2 \pm 15 %	Nm
M_t			Nm
a			m/s ²
w		20	g
Fu		20	A
Case		G 50a	

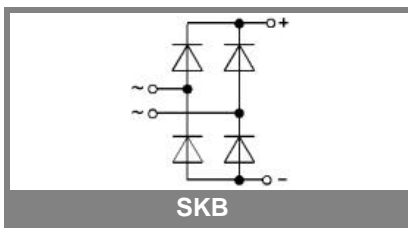

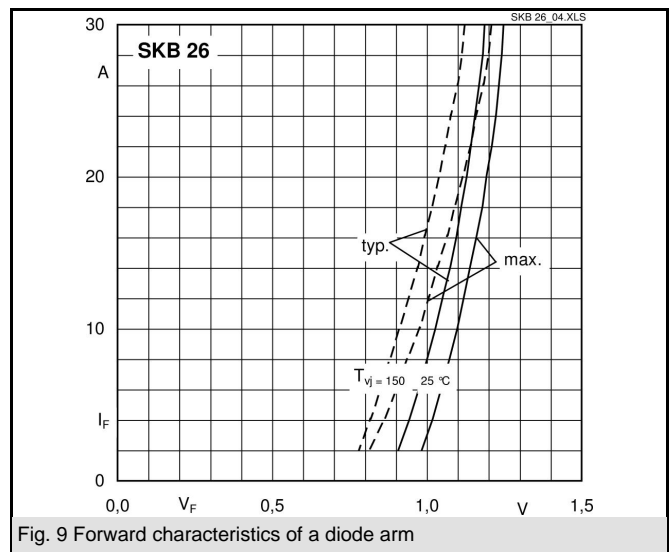
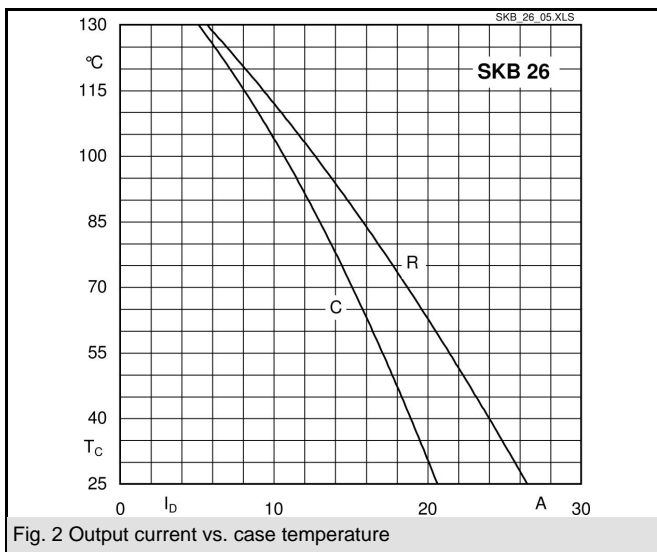
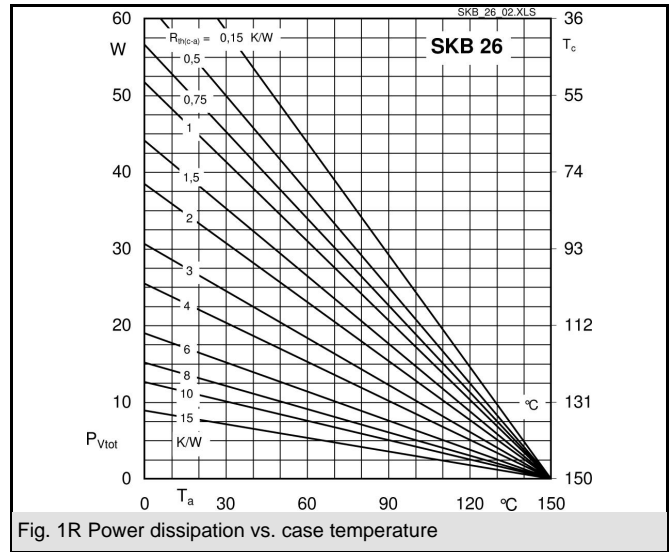
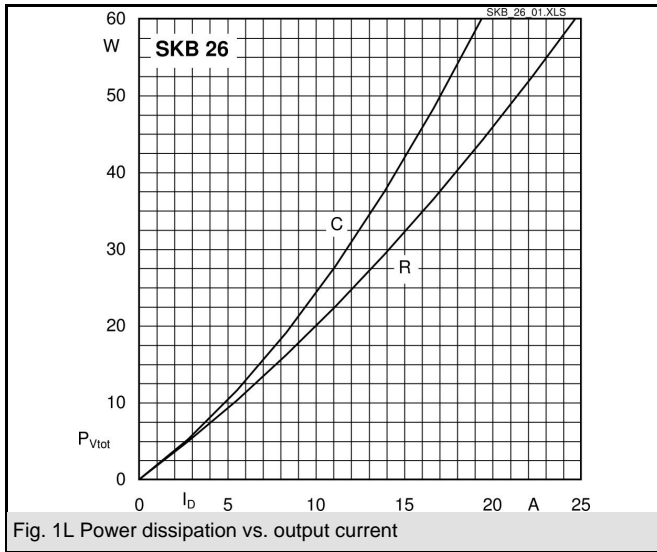

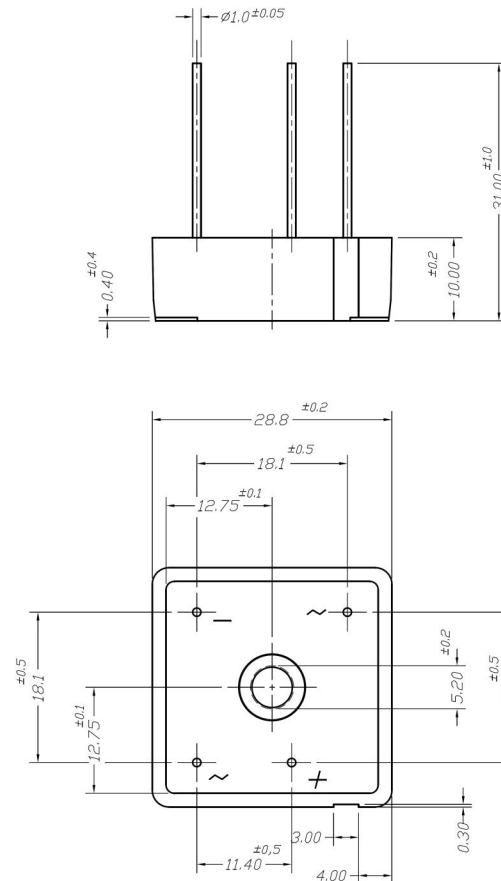

Case G 50a

* The specifications of our components may not be considered as an assurance of component characteristics. Components have to be tested for the respective application. Adjustments may be necessary. The use of SEMIKRON products in life support appliances and systems is subject to prior specification and written approval by SEMIKRON. We therefore strongly recommend prior consultation of our personal.