

SKB 30



Power Bridge Rectifiers

SKB 30

Features

- Isolated metal case with screw terminals
- Blocking voltage up to 1600 V
- High surge current
- Easy chassis mounting
- UL recognized, file no. E 63 532

Typical Applications*

- Single phase rectifiers for power supplies
- Input rectifiers for variable frequency drives
- Rectifiers for DC motor field supplies
- Battery charger rectifiers
- Recommended snubber network: RC: 0.1 μ F, 50 Ω ($P_R = 1$ W)

1) Freely suspended or mounted on an insulator

2) Mounted on a painted metal sheet of min. 250 x 250 x 1 mm

V_{RSM}, V_{RRM} V	V_{VRMS} V	$I_D = 30$ A ($T_c = 94$ °C) Types	C_{max} μ F	R_{min} Ω
200		SKB 30/02A1		0,15
400		SKB 30/04A1		0,3
800		SKB 30/08A1		0,5
1200		SKB 30/12A1		0,75
1400		SKB 30/14A1		0,9
1600		SKB 30/16A1		1

Symbol	Conditions	Values	Units
I_D	$T_a = 45$ °C, isolated ¹⁾ $T_a = 45$ °C, chassis ²⁾	6,5 15	A A
I_{DCL}	$T_a = 45$ °C, isolated ¹⁾ $T_a = 45$ °C, chassis ²⁾ $T_a =$ °C,	6 13 A	A A A
I_{FSM}	$T_{vj} = 25$ °C, 10 ms $T_{vj} = 150$ °C, 10 ms	370 320	A A
i^2t	$T_{vj} = 25$ °C, 8,3 ... 10 ms $T_{vj} = 150$ °C, 8,3 ... 10 ms	680 500	A ² s A ² s
V_F	$T_{vj} = 25$ °C, $I_F = 150$ A	max. 2,2	V
$V_{(TO)}$	$T_{vj} = 150$ °C	max. 0,85	V
r_T	$T_{vj} = 150$ °C	max. 12	m Ω
I_{RD}	$T_{vj} = 25$ °C, $V_{RD} = V_{RRM}$ $T_{vj} =$ °C, $V_{RD} = V_{RRM} \geq V$	300	μ A μ A
I_{RD}	$T_{vj} = 150$ °C, $V_{RD} = V_{RRM}$ $T_{vj} =$ °C, $V_{RD} = V_{RRM} \geq V$	5	mA mA
t_{rr}	$T_{vj} = 25$ °C	25	μ s
f_G		2000	Hz
$R_{th(j-a)}$	isolated ¹⁾ chassis ²⁾	8,5 3,3	K/W K/W
$R_{th(j-c)}$	total	0,7	K/W
$R_{th(c-s)}$	total	0,1	K/W
T_{vj}		- 40 ... + 150	°C
T_{stg}		- 55 ... + 150	°C
V_{isol}	a. c. 50 ... 60 Hz; r.m.s.; 1 s / 1 min.	3000 / 2500	V~
M_s	to heatsink	5 ± 15 %	Nm
M_t	to terminals	$1,5 \pm 15$ %	Nm
a			m/s ²
w		125	g
F_u		25	A
Case		G 12	

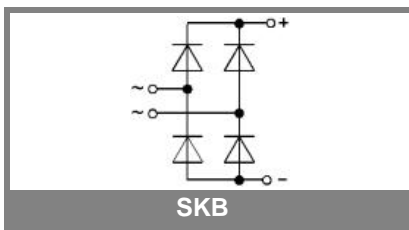

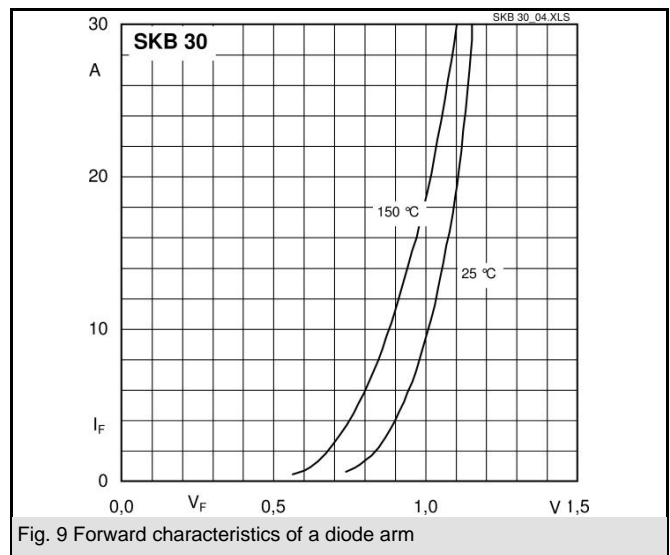
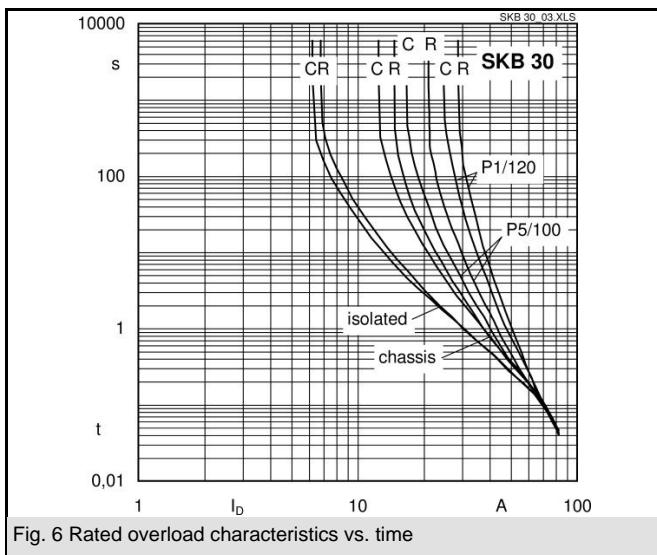
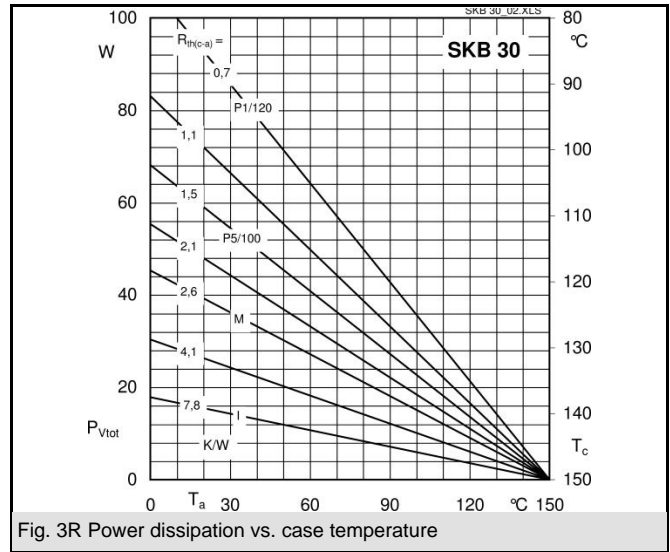
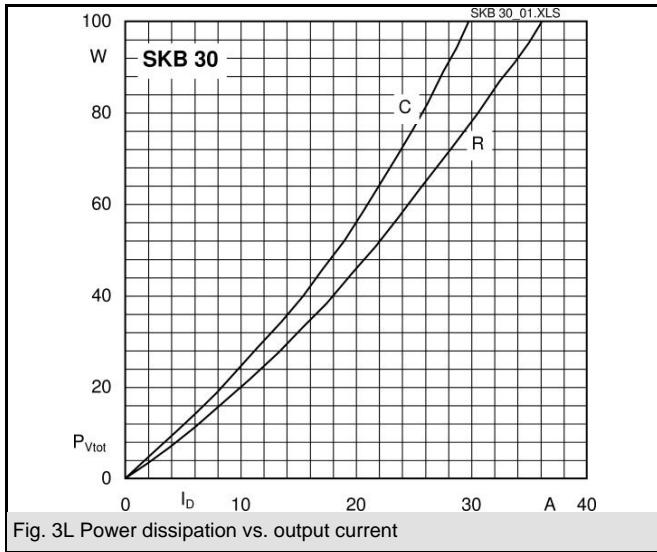

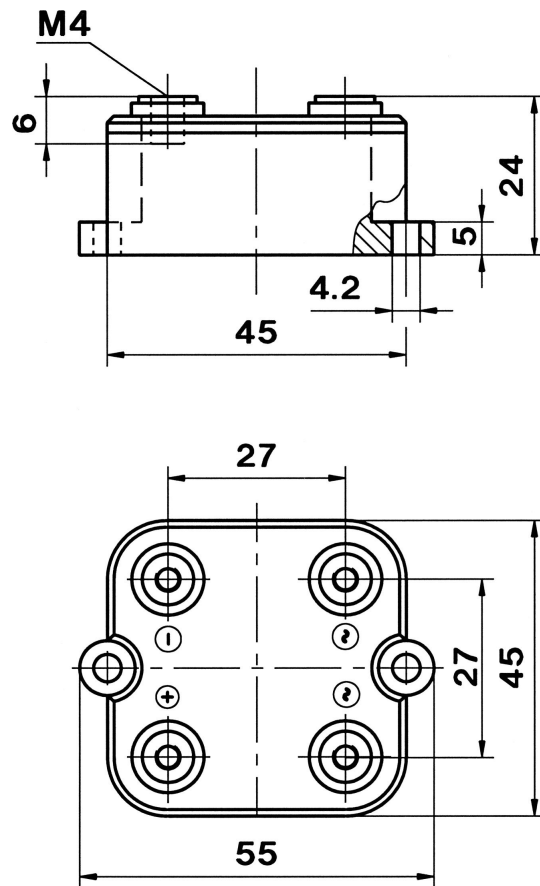

Case G 12

* The specifications of our components may not be considered as an assurance of component characteristics. Components have to be tested for the respective application. Adjustments may be necessary. The use of SEMIKRON products in life support appliances and systems is subject to prior specification and written approval by SEMIKRON. We therefore strongly recommend prior consultation of our personal.