



DS1270W

3.3V 16Mb Nonvolatile SRAM

www.maxim-ic.com

FEATURES

- Five years minimum data retention in the absence of external power
- Data is automatically protected during power loss
- Unlimited write cycles
- Low-power CMOS operation
- Read and write access times of 100ns
- Lithium energy source is electrically disconnected to retain freshness until power is applied for the first time
- Optional industrial (IND) temperature range of -40°C to +85°C

PIN ASSIGNMENT

NC	1	36	V _{CC}
A20	2	35	A19
A18	3	34	NC
A16	4	33	A15
A14	5	32	A17
A12	6	31	$\overline{\text{WE}}$
A7	7	30	A13
A6	8	29	A8
A5	9	28	A9
A4	10	27	A11
A3	11	26	$\overline{\text{OE}}$
A2	12	25	A10
A1	13	24	$\overline{\text{CE}}$
A0	14	23	DQ7
DQ0	15	22	DQ6
DQ1	16	21	DQ5
DQ2	17	20	DQ4
GND	18	19	DQ3

36-Pin Encapsulated Package
740mil Extended

PIN DESCRIPTION

A0–A20	- Address Inputs
DQ0–DQ7	- Data In/Data Out
$\overline{\text{CE}}$	- Chip Enable
$\overline{\text{WE}}$	- Write Enable
$\overline{\text{OE}}$	- Output Enable
V _{CC}	- Power (+3.3V)
GND	- Ground
NC	- No Connect

DESCRIPTION

The DS1270W 16Mb nonvolatile (NV) SRAMs are 16,777,216-bit, fully static, NV SRAMs organized as 2,097,152 words by 8 bits. Each NV SRAM has a self-contained lithium energy source and control circuitry that constantly monitors V_{CC} for an out-of-tolerance condition. When such a condition occurs, the lithium energy source is automatically switched on and write protection is unconditionally enabled to prevent data corruption. There is no limit on the number of write cycles that can be executed, and no additional support circuitry is required for microprocessor interfacing.

READ MODE

The DS1270 devices execute a read cycle whenever \overline{WE} (Write Enable) is inactive (high) and \overline{CE} (Chip Enable) and \overline{OE} (Output Enable) are active (low). The unique address specified by the 21 address inputs (A_0 – A_{20}) defines which of the 2,097,152 bytes of data is accessed. Valid data will be available to the eight data output drivers within t_{ACC} (Access Time) after the last address input signal is stable, providing that \overline{CE} and \overline{OE} (Output Enable) access times are also satisfied. If \overline{OE} and \overline{CE} access times are not satisfied, then data access must be measured from the later-occurring signal (\overline{CE} or \overline{OE}) and the limiting parameter is either t_{CO} for \overline{CE} or t_{OE} for \overline{OE} rather than t_{ACC} .

WRITE MODE

The DS1270 devices execute a write cycle whenever \overline{WE} and \overline{CE} signals are active (low) after address inputs are stable. The later-occurring falling edge of \overline{CE} or \overline{WE} will determine the start of the write cycle. The write cycle is terminated by the earlier rising edge of \overline{CE} or \overline{WE} . All address inputs must be kept valid throughout the write cycle. \overline{WE} must return to the high state for a minimum recovery time (t_{WR}) before another cycle can be initiated. The \overline{OE} control signal should be kept inactive (high) during write cycles to avoid bus contention. However, if the output drivers are enabled (\overline{CE} and \overline{OE} active), then \overline{WE} will disable the outputs in t_{ODW} from its falling edge.

DATA-RETENTION MODE

The DS1270W provides full-functional capability for V_{CC} greater than 3.0V and write protects by 2.8V. Data is maintained in the absence of V_{CC} without any additional support circuitry. The nonvolatile static RAMs constantly monitor V_{CC} . Should the supply voltage decay, the NV SRAMs automatically write protect themselves, all inputs become don't care, and all outputs become high-impedance. As V_{CC} falls below approximately 2.5V, a power-switching circuit connects the lithium energy source to RAM to retain data. During power-up, when V_{CC} rises above approximately 2.5V, the power-switching circuit connects external V_{CC} to RAM and disconnects the lithium energy source. Normal RAM operation can resume after V_{CC} exceeds 3.0V.

FRESHNESS SEAL

Each DS1270 device is shipped from Maxim with its lithium energy source disconnected, guaranteeing full energy capacity. When V_{CC} is first applied at a level greater than V_{TP} , the lithium energy source is enabled for battery backup operation.

ABSOLUTE MAXIMUM RATINGS

Voltage on Any Pin Relative to Ground	-0.3V to +4.6V
Operating Temperature Range	
Commercial:	0°C to +70°C
Industrial:	-40°C to +85°C
Storage Temperature Range	-40°C to +85°C
Lead Temperature (soldering, 10s)	+260°C
Note: EDIP is wave or hand soldered only.	

This is a stress rating only and functional operation of the device at these or any other conditions above those indicated in the operation sections of this specification is not implied. Exposure to absolute maximum rating conditions for extended periods of time may affect reliability.

RECOMMENDED DC OPERATING CONDITIONS(T_A: See Note 10)

PARAMETER	SYMBOL	MIN	TYP	MAX	UNITS	NOTES
Power-Supply Voltage	V _{CC}	3.0	3.3	3.6	V	
Logic 1 Input Voltage	V _{IH}	2.2		V _{CC}	V	
Logic 0 Input Voltage	V _{IL}	0.0		+0.4	V	

DC ELECTRICAL CHARACTERISTICS(T_A: See Note 10; V_{CC} = 3.3V ± 0.3V)

PARAMETER	SYMBOL	MIN	TYP	MAX	UNITS	NOTES
Input Leakage Current	I _{IL}	-4.0		+4.0	μA	
I/O Leakage Current	I _{IO}	-4.0		+4.0	μA	
Output Current at 2.2V	I _{OH}	-1.0			mA	
Output Current at 0.4V	I _{OL}	2.0			mA	
Standby Current $\overline{CE} = 2.2V$	I _{CCS1}		150	300	μA	
Standby Current $\overline{CE} = V_{CC} - 0.2V$	I _{CCS2}		100	200	μA	
Operating Current	I _{CCO1}			50	mA	
Write Protection Voltage	V _{TP}	2.8	2.9	3.0	V	

CAPACITANCE(T_A = +25°C)

PARAMETER	SYMBOL	MIN	TYP	MAX	UNITS	NOTES
Input Capacitance	C _{IN}		20	40	pF	
Input/Output Capacitance	C _{I/O}		20	40	pF	

AC ELECTRICAL CHARACTERISTICS (T_A : See Note 10; $V_{CC} = 3.3V \pm 0.3V$)

PARAMETER	SYMBOL	DS1270W-100		UNITS	NOTES
		MIN	MAX		
Read Cycle Time	t_{RC}	100		ns	
Access Time	t_{ACC}		100	ns	
\overline{OE} to Output Valid	t_{OE}		50	ns	
\overline{CE} to Output Valid	t_{CO}		100	ns	
\overline{OE} or \overline{CE} to Output Active	t_{COE}	5		ns	5
Output High-Z from Deselection	t_{OD}		35	ns	5
Output Hold from Address Change	t_{OH}	5		ns	
Write Cycle Time	t_{WC}	100		ns	
Write Pulse Width	t_{WP}	75		ns	3
Address Setup Time	t_{AW}	0		ns	
Write Recovery Time	t_{WR1}	5		ns	12
	t_{WR2}	20		ns	13
Output High-Z from \overline{WE}	t_{ODW}		35	ns	5
Output Active from \overline{WE}	t_{OEWE}	5		ns	5
Data Setup Time	t_{DS}	40		ns	4
Data Hold Time	t_{DH1}	0		ns	12
	t_{DH2}	20		ns	13

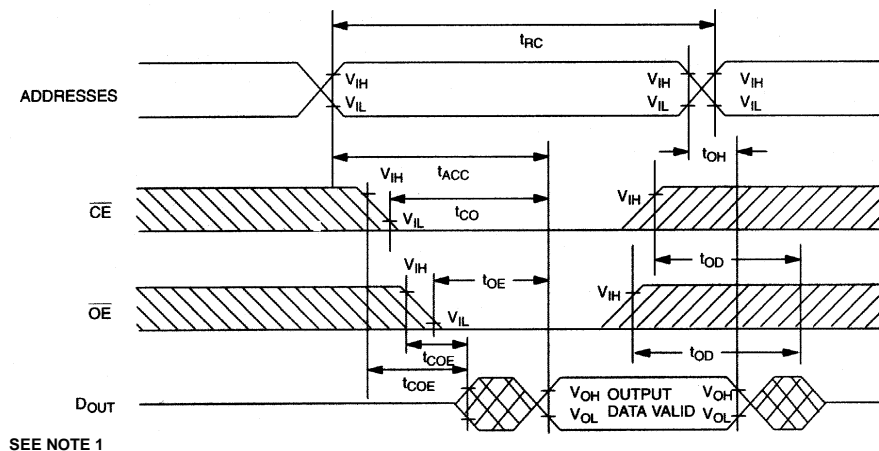
TIMING DIAGRAM: READ CYCLE

TIMING DIAGRAM: WRITE CYCLE 1

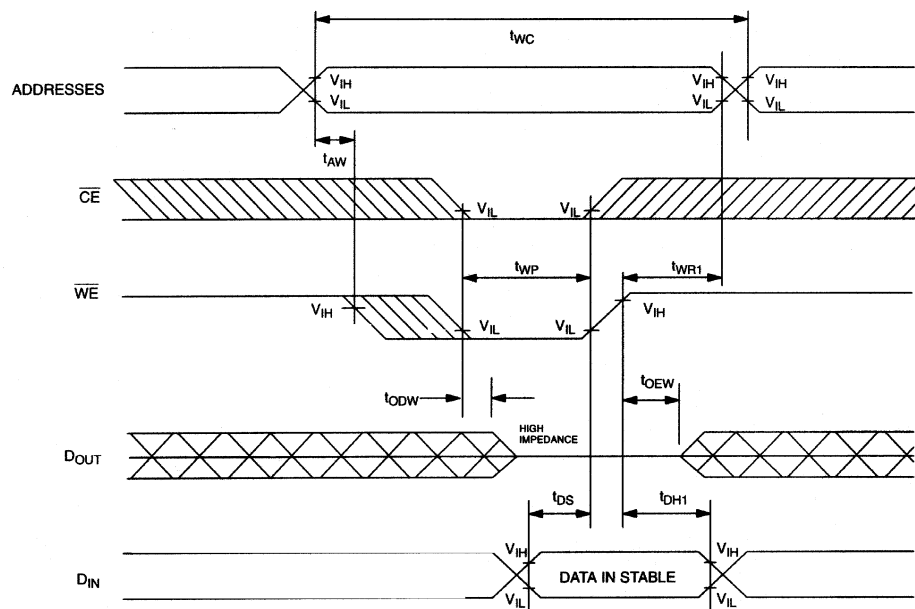

TIMING DIAGRAM: WRITE CYCLE 2

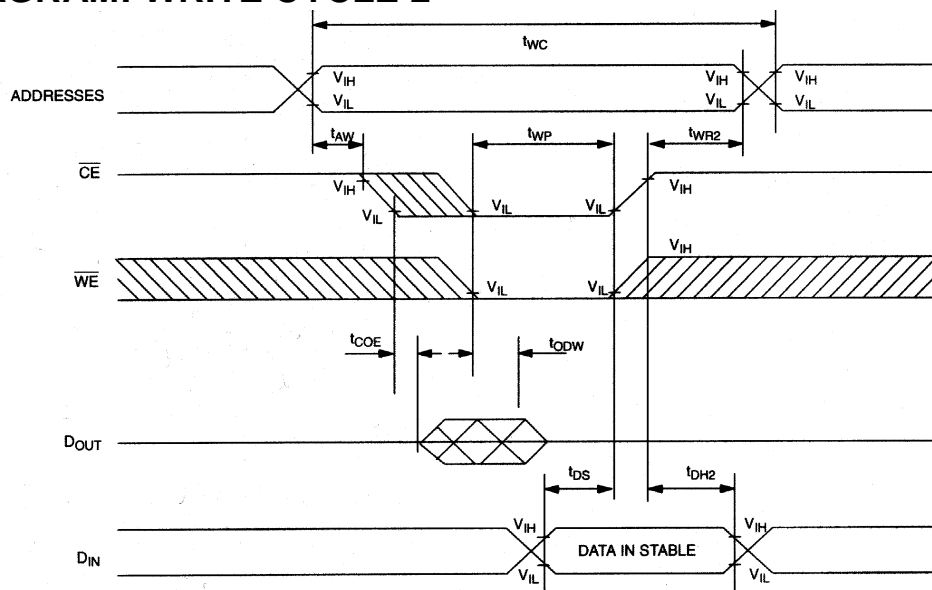

POWER-DOWN/POWER-UP CONDITION

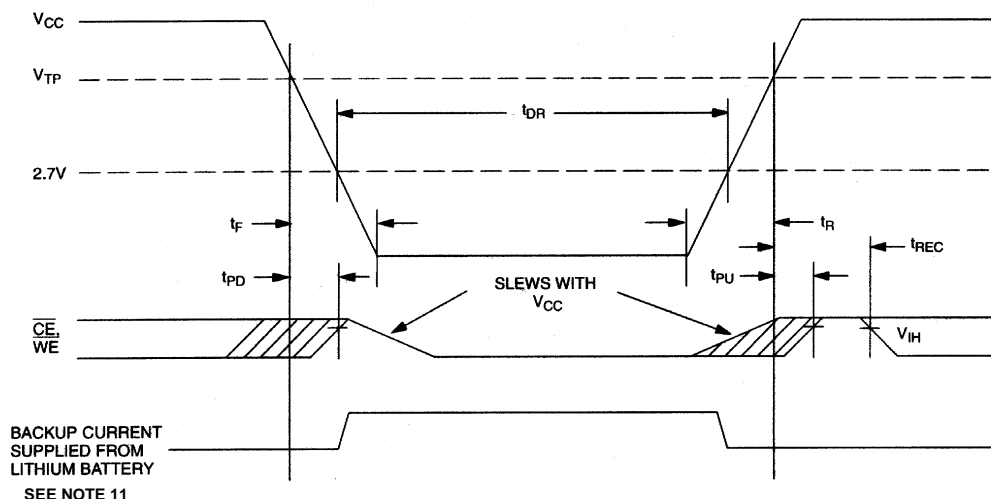

POWER-DOWN/POWER-UP TIMING

(T_A : See Note 10)

PARAMETER	SYMBOL	MIN	TYP	MAX	UNITS	NOTES
V_{CC} Fail Detect to \overline{CE} and \overline{WE} Inactive	t_{PD}			1.5	μs	11
V_{CC} Slew from V_{TP} to 0V	t_F	150			μs	
V_{CC} Slew from 0V to V_{TP}	t_R	150			μs	
V_{CC} Valid to \overline{CE} and \overline{WE} Inactive	t_{PU}			2	ms	
V_{CC} Valid to End of Write Protection	t_{REC}			125	ms	

($T_A = +25^\circ\text{C}$)

PARAMETER	SYMBOL	MIN	TYP	MAX	UNITS	NOTES
Expected Data-Retention Time	t_{DR}	5			years	9

WARNING:

Under no circumstance are negative undershoots, of any amplitude, allowed when device is in battery backup mode.

NOTES:

- \overline{WE} is high for a read cycle.
- $\overline{OE} = V_{IH}$ or V_{IL} . If $\overline{OE} = V_{IH}$ during write cycle, the output buffers remain in a high-impedance state.
- t_{WP} is specified as the logical AND of \overline{CE} and \overline{WE} . t_{WP} is measured from the latter of \overline{CE} or \overline{WE} going low to the earlier of \overline{CE} or \overline{WE} going high.
- t_{DS} is measured from the earlier of \overline{CE} or \overline{WE} going high.
- These parameters are sampled with a 5pF load and are not 100% tested.
- If the \overline{CE} low transition occurs simultaneously with or later than the \overline{WE} low transition, the output buffers remain in a high-impedance state during this period.
- If the \overline{CE} high transition occurs prior to or simultaneously with the \overline{WE} high transition, the output buffers remain in a high-impedance state during this period.
- If \overline{WE} is low or the \overline{WE} low transition occurs prior to or simultaneously with the \overline{CE} low transition, the output buffers remain in a high-impedance state during this period.

9. Each DS1270 has a built-in switch that disconnects the lithium source until V_{CC} is first applied by the user. The expected t_{DR} is defined as accumulative time in the absence of V_{CC} starting from the time power is first applied by the user.
10. All AC and DC electrical characteristics are valid over the full operating temperature range. For commercial products, this range is 0°C to $+70^{\circ}\text{C}$. For industrial products (IND), this range is -40°C to $+85^{\circ}\text{C}$.
11. In a power-down condition, the voltage on any pin may not exceed the voltage on V_{CC} .
12. t_{WR1} and t_{DH1} are measured from \overline{WE} going high.
13. t_{WR2} and t_{DH2} are measured from \overline{CE} going high.
14. DS1270 modules are recognized by Underwriters Laboratories (UL) under file E99151.

DC TEST CONDITIONS

Outputs Open

Cycle = 200ns for operating current

All voltages are referenced to ground

AC TEST CONDITIONS

Output Load: 100pF + 1TTL Gate

Input Pulse Levels: 0 to 2.7V

Timing Measurement Reference Levels

Input: 1.5V

Output: 1.5V

Input Pulse Rise and Fall Times: 5ns

ORDERING INFORMATION

PART	TEMP RANGE	SUPPLY TOLERANCE	PIN-PACKAGE	SPEED GRADE (ns)
DS1270W-100#	0°C to $+70^{\circ}\text{C}$	$3.3\text{V} \pm 0.3\text{V}$	36 740 EDIP	100
DS1270W-100IND#	-40°C to $+85^{\circ}\text{C}$	$3.3\text{V} \pm 0.3\text{V}$	36 740 EDIP	100

#Denotes a RoHS-compliant device that may include lead(Pb) that is exempt under the RoHS requirements.

PACKAGE INFORMATION

For the latest package outline information and land patterns, go to www.maxim-ic.com/packages. Note that a "+", "#", or "-" in the package code indicates RoHS status only. Package drawings may show a different suffix character, but the drawing pertains to the package regardless of RoHS status.

PACKAGE TYPE	PACKAGE CODE	OUTLINE NO.	LAND PATTERN NO.
36 EDIP	MDT36#2	21-0245	—

REVISION HISTORY

REVISION DATE	DESCRIPTION	PAGES CHANGED
11/10	Updated the storage information, soldering temperature, and lead temperature information in the <i>Absolute Maximum Ratings</i> section; removed the -150 MIN/MAX information from the <i>AC Electrical Characteristics</i> table; updated the <i>Ordering Information</i> table (removed -150 parts and leaded -100 parts); replaced the package outline drawing with the <i>Package Information</i> table	1, 3, 4, 7