

4

3

2

1

THIS DRAWING IS UNPUBLISHED. RELEASED FOR PUBLICATION
 © COPYRIGHT - By - ALL RIGHTS RESERVED.

LOC	DIST	REVISIONS			
P	LTR	DESCRIPTION	DATE	DWN	APVD
G	14	C2	REVISED PER ECO-11-004917	11MAR11	RK HMR

AMP WIRE RANGE	Listed	LR7189 Certified
16-14 AWG SOLID OR STRANDED	16-14 AWG SOLID OR STRANDED	16-14 AWG SOLID OR STRANDED

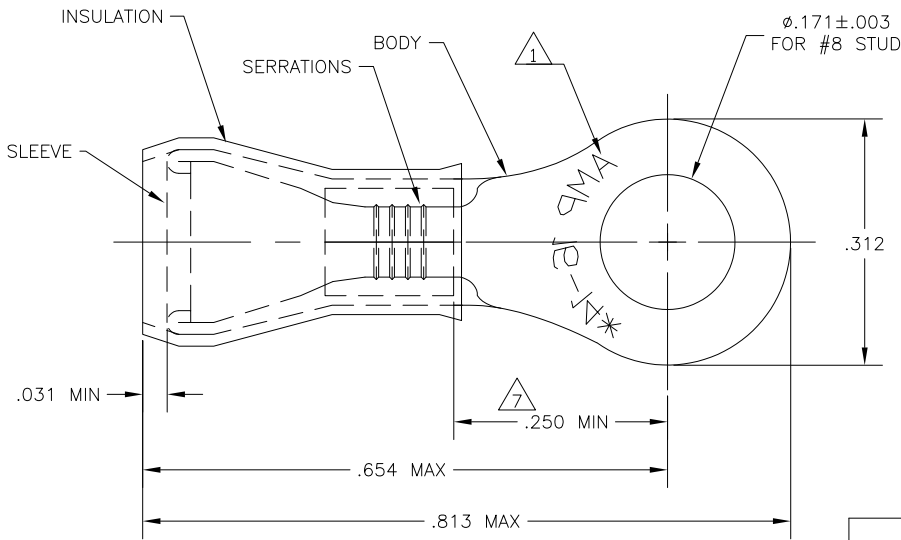

- 1 STAMP AMP 16-14*, APPROX AS SHOWN.
- 2 TONGUE THICKNESS IS $.031 \pm .002$
- 3 FOR .115-.170 WIRE INSULATION DIA
- 4 MAX RECOMMENDED OPERATING TEMP IS 105°C.
- 5 300 VOLT MAX RATING.
- 6 WIRE CROSS SECTIONAL AREA RANGE 1.04-2.62mm [2,050-5,180 CIR MILS]
- 7 APPLIES FROM EDGE OF METAL WIRE BBL TO CENTER OF STUD HOLE.

100	LOOSE PIECE, BOX	BODY & SLEEVE: COPPER PER ASTM B152 TIN PL. PER ASTM B-545 INSULATION: NYLON, TYPE I, PER ASTM D4066 COLOR: BLUE	8-53941-1
5000	ON TAPE, REEL		53941-2
1000	LOOSE PIECE		53941-1
QTY	PACKAGING	MATERIAL / FINISH	PART NO

THIS DRAWING IS A CONTROLLED DOCUMENT.		DWN jr_ruth 02MAR10	TE Connectivity	
DIMENSIONS: INCHES		CHK T MICHELUTTI 02MAR10		
TOLERANCES UNLESS OTHERWISE SPECIFIED:		APVD T MICHELUTTI 02MAR10	NAME WIRE TERMINAL PIDG, RING TONGUE WIRE SIZE: 16-14	
0 PLC ± -		PRODUCT SPEC	SIZE	
1 PLC ± -		UL486A-UL486B	CAGE CODE	DRAWING NO
2 PLC ± -		APPLICATION SPEC	114-2157	RESTRICTED TO
3 PLC ± .008		WEIGHT	A300779	53941
4 PLC ± -		MATERIAL	SCALE 8:1 SHEET 1 of 1 REV C2	
ANGLES ± 1°		FINISH	CUSTOMER DRAWING	
SEE TABLE		SEE TABLE		