

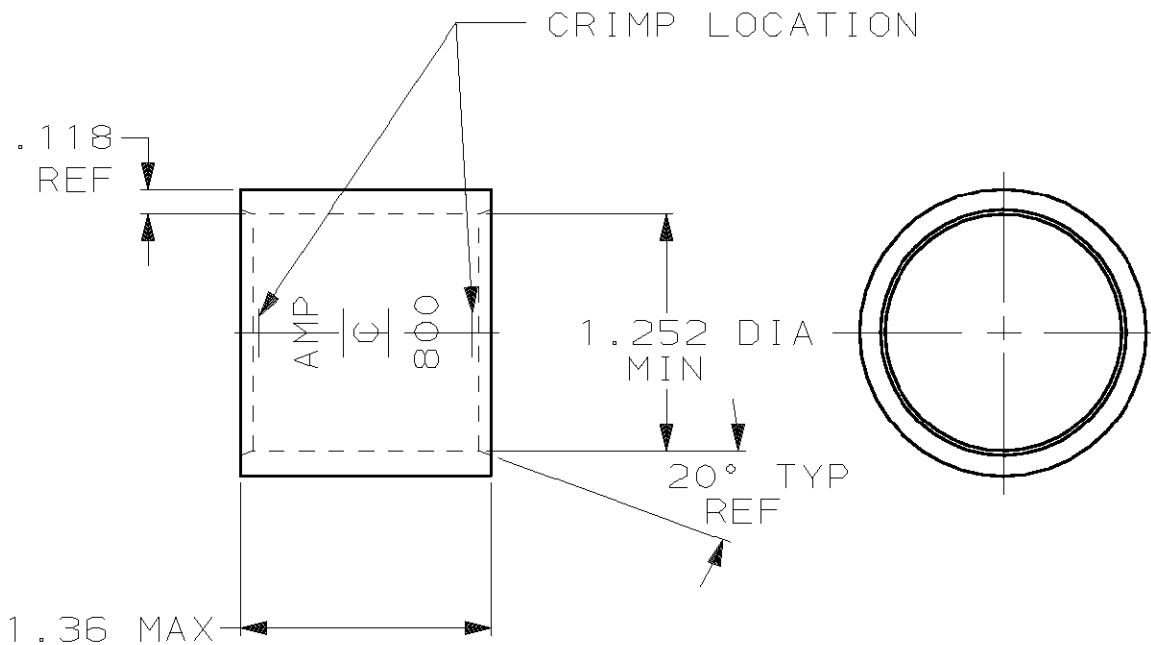

LOC G	DIST 86	P	F	REVISIONS		
			LTR	DESCRIPTION	DATE	APPROVED
			F	REV PER 0G3A-0637-01	030CT02	JR/MS

1 PREPRODUCTION - FASR REQ



750-850 MCM	CLEANED, UNPLATED	1-324454-0
	TIN PL PER ASTM B545 .000150 MIN THK	324454
RANGE	FINISH	PART NO

DO NOT SCALE PRINT.
UNLESS SPECIFIED
DIMENSIONS IN INCHES
TOLERANCES ON:
2 PLC DEC ± -
3 PLC DEC ± -
ANGLES ± -

MATERIAL
COPPER
ASTM-B-75
ANNEALED

FINISH
SEE TABLE

DR 1/16/89 P FORTNEY
CHK 6/20/89 MS FEHER
APPD 6/20/89 WJ VOCKROTH
APPD 6/20/89 R ADAMS
PRODUCT SPEC -
APPLICATION SPEC -
WEIGHT .223 LB.

AMP | AMP INCORPORATED
Harrisburg, Pa. 17105

NAME
WIRE SPLICE, PARALLEL,
AMPOWER, WIRE SIZE: 800 MCM

SIZE A	FSCM NO 00779	DRAWING NO 324454
SCALE 1:1	SHEET 1 OF 1	



THIS DRAWING IS UNPUBLISHED. RELEASED FOR PUBLICATION. BY AMP INCORPORATED. ALL INTERNATIONAL RIGHTS RESERVED. © COPYRIGHT 19