

4

3

2

1

THIS DRAWING IS UNPUBLISHED. RELEASED FOR PUBLICATION  
 © COPYRIGHT - By - ALL RIGHTS RESERVED.

LOC	DIST	REVISIONS			
P	LTR	DESCRIPTION	DATE	DWN	APVD
G	14	K1	REVISED PER ECO-11-004820	11MAR11	RK HMR

AMP WIRE RANGE	Listed FILE E13288	LR7189 Certified
22-16 AWG SOLID OR STRANDED	22-16 AWG SOLID OR STRANDED	22-16 AWG SOLID OR STRANDED

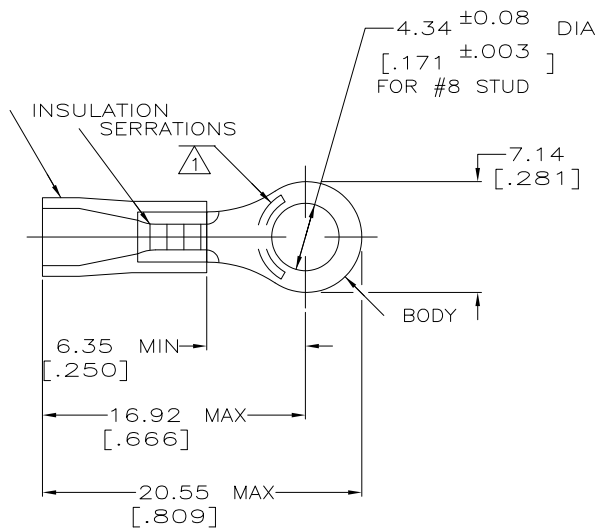

- 1 STAMP AMP 22-18\* APPROX AS SHOWN  
 22-16 TERMINALS ARE STAMPED 22-18 IN  
 ACCORDANCE WITH MILITARY SPEC MIL-T-7928  
 COMMERCIAL WIRE RANGE IS 22-16
- 2 WIRE INSULATION DIA: 2.67-3.56 [0.105-.140]
- 3 TONGUE MATERIAL THK: 0.79<sup>+0.05</sup> [0.031<sup>+0.002</sup>]
- 4 SUPERSEDED BY 8-34145-1
- 5 MATERIAL: BODY - CU PER ASTM B152  
 SLEEVE - PVC, COLOR - RED

50	LOOSE PC,BAG	8-34145-5	4
5	LOOSE PC,BLS	8-34145-4	
100	LOOSE PC,BOX	8-34145-1	
5000	ON TAPE, REEL	2-34145-1	
1000	LOOSE PIECE	34145	
QTY	PACKAGE TYPE	PART NO.	

AMP INCORPORATED CUSTOMER SERVICE SYSTEMS		MAX RECOMMENDED OPERATING TEMPERATURE: 105°C [221°F]	THIS DRAWING IS A CONTROLLED DOCUMENT.		DWN DK SCHRUM 08/06/92	TE Connectivity			
FOR ADDITIONAL PRODUCT INFORMATION OR COPIES OF DRAWINGS AND TECHNICAL DOCUMENTS	PRODUCT INFORMATION CENTER 1-800-522-6752	VOLTAGE RATING: 600V MAX (1000V FIXTURE OR SIGN)	DIMENSIONS: MM [INCHES]	TOLERANCES UNLESS OTHERWISE SPECIFIED:	CHK RE HERSEY 11/10/92	NAME M BARNABA 11/10/92			
FOR APPLICATION	TOOLING ASSISTANCE CENTER 1-800-722-1111	CIRCULAR MIL AREA: 0.26-1.65mm <sup>2</sup> [509-3260] SOLID OR STRANDED		0 PLC ± - 1 PLC ± - 2 PLC ± 0.20[008] 3 PLC ± - 4 PLC ± - ANGLES ± -	APVD M BARNABA 11/10/92	PRODUCT SPEC UL 486A			
TOOLING INFORMATION	1-800-722-1111	THIS DRAWING IS A CONTROLLED DOCUMENT FOR AMP INCORPORATED. IT IS SUBJECT TO CHANGE AND THE CONTROLLING ENGINEERING ORGANIZATION SHOULD BE CONTACTED FOR THE LATEST REVISION.	MATERIAL -5	FINISH TIN PER ASTM B545	APPLICATION SPEC -	SIZE A3	CAGE CODE 00779	DRAWING NO C-34145	RESTRICTED TO -
FOR ORDER ENTRY	1-800-526-5142				WEIGHT -	CUSTOMER DRAWING	SCALE 4:1	SHEET 1 OF 1	REV K1

1470-19 (3/11)