

THIS DRAWING IS UNPUBLISHED. RELEASED FOR PUBLICATION. ALL RIGHTS RESERVED.

LOC	REV	DESCRIPTION	DATE	OWN	APP
G	14				
		M1	REVISED PER ECO-11-004820	11MAR11	RK HMR



AMP WIRE RANGE	E13288 Listed
12-10 AWG SOLID OR STRANDED	12-10 AWG STRANDED
LR7189 Certified	MILITARY P/N AND CLASS
12-10 AWG SOLID OR STRANDED	MS20659-106 CLASS 1 & 2 P/N 33459 CLASS 2 P/N 2-33459-6

△ STAMP AMP 12-10* APPROX AS SHOWN

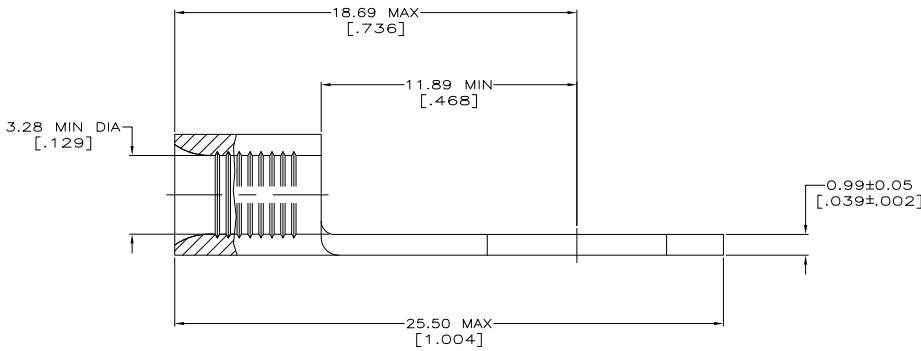
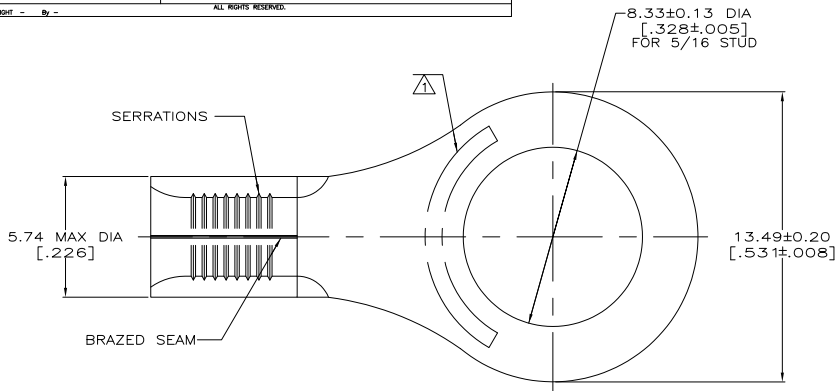

AMP INCORPORATED CUSTOMER SERVICE SYSTEMS		MAX RECOMMENDED OPERATING TEMPERATURE: 170° C MAX
FOR ADDITIONAL PRODUCT INFORMATION OR COPIES OF DRAWINGS AND TECHNICAL DOCUMENTS	PRODUCT INFORMATION CENTER 1-800-522-6752	VOLTAGE RATING: NOT APPLICABLE
FOR APPLICATION TOOLING INFORMATION	TOOLING ASSISTANCE CENTER 1-800-722-1111	WIRE CROSS SECTIONAL AREA RANGE: 2.62-6.64mm ² [5,180-13,100] CIR MILS SOLID OR STRANDED
FOR ORDER ENTRY	1-800-526-5142	

---	LOOSE PIECE	UNPLATED, FULLY ANNEALED	33459-4
50	LOOSE PIECE BOX 33459	TIN PLATE 0.00254[.000100] MIN THK PER MIL-T-10727	8-33459-2
OBSOLETE	LOOSE PIECE	UNPLATED	2-33459-9
2500	33459 ON TAPE	TIN PLATE 0.00254[.000100] MIN THK PER MIL-T-10727	2-33459-6
---	LOOSE PIECE	TIN PLATE 0.00254[.000100] MIN THK PER MIL-T-10727	33459
QUANTITY	PACKAGE TYPE	FINISH	PART NO

THIS DRAWING IS A CONTROLLED DOCUMENT.		BY TA BRINKMAN 3-17-93	TE Connectivity	
DIMENSIONS: mm [INCHES]		CHK DA PATTERSON 3-17-93	TERMINAL, RING TONGUE, SOLISTRAND™	
OTHERWISE SPECIFIED:		APP DE MILLER 3-17-93	RESTRICTED TO	
MATERIAL: COPPER PER ASTM B-152 ANNEALED		FINISH: SEE TABLE	WEIGHT: --	SIZE: A2
			QTY: 00779	DRAWING NO: 33459
			SCALE: 3:1	SHEET: 1 of 1
				REV: M1

1471-9 (5/11)

33459

A