

4

3

2

1

THIS DRAWING IS UNPUBLISHED. RELEASED FOR PUBLICATION
 © COPYRIGHT - By - ALL RIGHTS RESERVED.

LOC	DIST	REVISIONS			
P	LTR	DESCRIPTION	DATE	DWN	APVD
G	14				
	G2	REVISED PER ECO-11-004917	11MAR11	RK	HMR

AMP WIRE RANGE	E13288 Listed	LR7189 Certified
16-14 AWG SOLID OR STRANDED	16-14 AWG SOLID OR STRANDED	16-14 AWG SOLID OR STRANDED

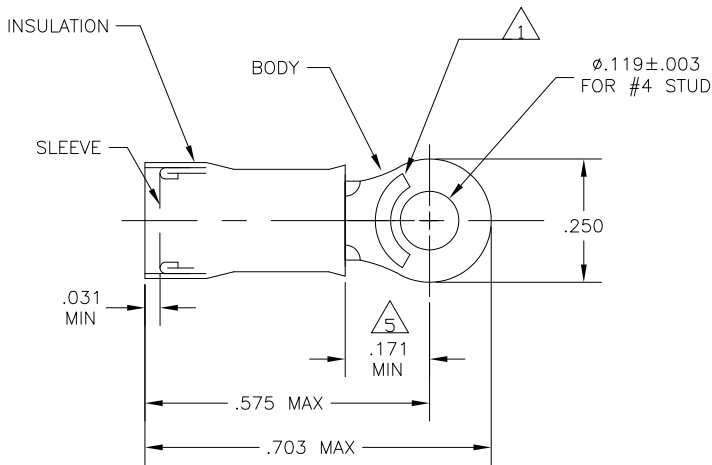

- △ 1 STAMP AMP 16-14* APPROX AS SHOWN
- 2 WIRE INSULATION DIA: .115-.170
- 3 TONGUE MATERIAL THK: .031±.002
- △ 4 BODY & SLEEVE: CU PER ASTM B152
 BODY & SLEEVE: TIN PLATE .000100 MIN
 EXT THK PER ASTM B545
 INSULATION: NYLON PER ASTM D4066
 COLOR - BLUE
- △ 5 APPLIES FROM EDGE OF METAL WIRE BARREL
 TO CENTER OF STUD HOLE.

100	LOOSE PIECE, BOX	△ 4	8-328996-1
2500	328996 ON TAPE & REEL	△ 4	2-328996-1
---	LOOSE PIECE	△ 4	328996
QTY	PACKAGE TYPE	MATERIAL FINISH	PART NO

CUSTOMER SERVICE SYSTEMS		MAX RECOMMENDED OPERATING TEMPERATURE: 170°C MAX	THIS DRAWING IS A CONTROLLED DOCUMENT.		DWN JR RUTH 02MAR10	TE Connectivity		
FOR ADDITIONAL PRODUCT INFORMATION OR COPIES OF DRAWINGS AND TECHNICAL DOCUMENTS	PRODUCT INFORMATION CENTER 1-800-522-6752	VOLTAGE RATING: 300 V MAX	DIMENSIONS: INCHES	TOLERANCES UNLESS OTHERWISE SPECIFIED: 0 PLC ± - 1 PLC ± - 2 PLC ± - 3 PLC ± .008 4 PLC ± - ANGLES ± -	CHK T MICHELUTTI 02MAR10	NAME TERMINAL, RING TONGUE, PIDG		
FOR APPLICATION TOOLING INFORMATION	TOOLING ASSISTANCE CENTER 1-800-722-1111	CIRCULAR MIL AREA: 1.04-2.62mm ² [2,050-5,180] STRANDED OR SOLID			APVD T MICHELUTTI 02MAR10	WIRE SIZE: 16-14 AWG		
FOR ORDER ENTRY	1-800-526-5142	THIS DRAWING IS A CONTROLLED DOCUMENT FOR AMP INCORPORATED. IT IS SUBJECT TO CHANGE AND THE CONTROLLING ENGINEERING ORGANIZATION SHOULD BE CONTACTED FOR THE LATEST REVISION.	MATERIAL SEE TABLE	FINISH SEE TABLE	APPLICATION SPEC 114-2157	SIZE A3	CAGE CODE 00779	
					WEIGHT -	DRAWING NO C-328996	RESTRICTED TO -	
CUSTOMER DRAWING						SCALE 5:1	SHEET 1 OF 1	REV G2