

4

3

2

1

THIS DRAWING IS UNPUBLISHED. RELEASED FOR PUBLICATION
 © COPYRIGHT - By - ALL RIGHTS RESERVED.

LOC		DIST		REVISIONS			
P	LTR	DESCRIPTION		DATE	DWN	APVD	
	J1	REVISED PER ECO-11-004820		11MAR11	RK	HMR	

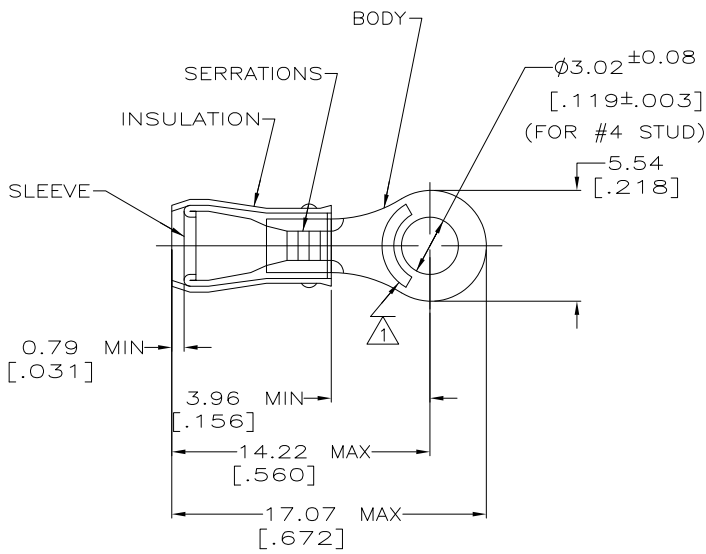

AMP WIRE RANGE	E13288	LR7189 Certified
22-16 AWG SOLID OR STRANDED	22-16 AWG SOLID OR STRANDED	22-16 AWG SOLID OR STRANDED

- 1 STAMP AMP 22-18* APPROX AS SHOWN
22-16 TERMINALS ARE STAMPED 22-18 IN
ACCORDANCE WITH MILITARY SPEC MIL-T-7928
COMMERCIAL WIRE RANGE IS 22-16
- 2 WIRE INSUL DIA, 2.03-3.18 [.080-.125]
- 3 TONGUE MATERIAL THK, 0.79±0.05
[.031±.002]

QTY	PACKAGE TYPE	PART NO
100	LOOSE PIECE, BOX	8-320553-1
5000	ON TAPE, REEL	2-320553-2
1000	LOOSE PIECE	320553
MILITARY P/N & CLASS		

AMP INCORPORATED CUSTOMER SERVICE SYSTEM	
FOR ADDITIONAL PRODUCT INFORMATION OR COPIES OF DRAWINGS AND TECHNICAL DOCUMENTS	PRODUCT INFORMATION CENTER 1-800-522-6752
FOR APPLICATION TOOLING INFORMATION	TOOLING ASSISTANCE CENTER 1-800-722-1111
FOR ORDER ENTRY	1-800-526-5142

MAX RECOMMENDED OPERATING TEMPERATURE: 105° C [221 F]
VOLTAGE RATING: 300 V MAX
CIRCULAR MIL AREA: 0.26mm ² - 1.65mm ² [509-3260]

THIS DRAWING IS A CONTROLLED DOCUMENT.	
DIMENSIONS: mm [INCHES]	TOLERANCES UNLESS OTHERWISE SPECIFIED:
	0 PLC ± -
	1 PLC ± -
	2 PLC ± 0.20[.008]
	3 PLC ± -
	4 PLC ± -
	ANGLES ± -
MATERIAL BODY,SLV,COPPER PER ASTM B INSUL,NYLON,COLOR,RED	FINISH 15800Y & SLV,TIN PLATE PER MIL-1-10727

DWN M ELLIS 24MAY95	TE TE Connectivity	
CHK C PRESNELL 24MAY95	NAME	
APVD N BIRCH 24MAY95	PRODUCT SPEC	
	MIL-T-7928 & UL 486A	
	APPLICATION SPEC	
WEIGHT	SIZE	CAGE CODE
	A3	00779
	DRAWING NO	320553
CUSTOMER DRAWING		RESTRICTED TO
SCALE	SHEET	REV
4:1	1 OF 1	J1