

4

3

2

1

THIS DRAWING IS UNPUBLISHED. RELEASED FOR PUBLICATION  
 © COPYRIGHT - BY TYCO ELECTRONICS CORPORATION. ALL RIGHTS RESERVED.

LOC	DIST	REVISIONS				
P	LTR	DESCRIPTION	DATE	DWN	APVD	
G	14	A1	REV PER ECR07-016469	18JUL07	JR	TM

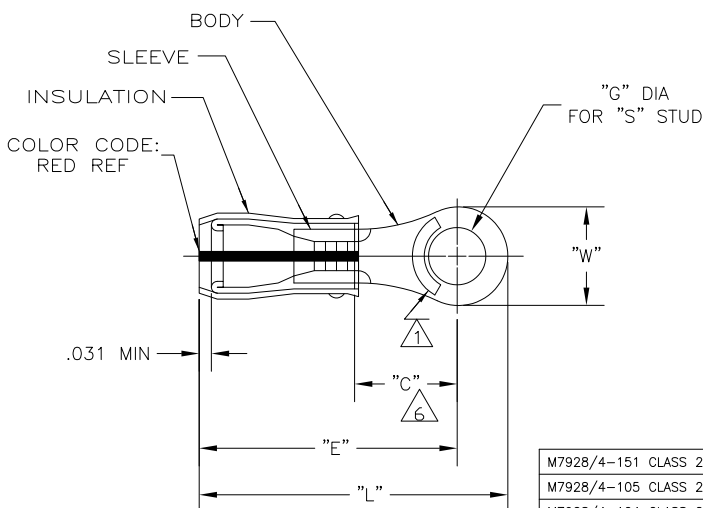

- 1 STAMP AMP 22-18\* APPROX AS SHOWN  
22-16 TERMINALS ARE STAMPED 22-18 IN  
ACCORDANCE WITH MILITARY SPEC MIL-T-7928  
COMMERCIAL WIRE RANGE IS 22-16
- 2 WIRE INSULATION DIA: .080-.125
- 3 TONGUE MATERIAL THK: .031±.002
- 4 BODY & SLEEVE: TIN PLATE PER  
ASTM B545,
- 5 BODY & SLEEVE- CU PER ASTM B152  
INSULATION - PVF2, COLOR - NATURAL
- 6 APPLIES FROM EDGE OF METAL WIRE BARREL  
TO CENTER OF STUD HOLE.

M7928/4-151 CLASS 2	.713	.530 MIN	.934 MAX	.515±.005	1/2"	1.298 MAX	1000	LOOSE PIECE	1-696422-0
M7928/4-105 CLASS 2	.531	.546 MIN	.950 MAX	.390±.005	3/8"	1.223 MAX	1000	LOOSE PIECE	696422-9
M7928/4-104 CLASS 2	.469	.437 MIN	.841 MAX	.328±.005	5/16"	1.083 MAX	1000	LOOSE PIECE	696422-8
M7928/4-150 CLASS 2	.469	.437 MIN	.841 MAX	.265±.005	1/4"	1.083 MAX	1000	LOOSE PIECE	696422-7
M7928/4-103 CLASS 2	.312	.281 MIN	.685 MAX	.197±.003	#10	.849 MAX	1000	LOOSE PIECE	696422-6
M7928/4-149 CLASS 2	.312	.281 MIN	.685 MAX	.171±.003	#8	.849 MAX	1000	LOOSE PIECE	696422-5
M7928/4-102 CLASS 2	.250	.250 MIN	.654 MAX	.145±.003	#6	.787 MAX	1000	LOOSE PIECE	696422-4
M7928/4-101 CLASS 2	.218	.156 MIN	.560 MAX	.145±.003	#6	.677 MAX	1000	LOOSE PIECE	696422-3
M7928/4-148 CLASS 2	.218	.156 MIN	.560 MAX	.119±.003	#4	.677 MAX	1000	LOOSE PIECE	696422-2
MILITARY P/N & CLASS	"W"	"C"	"E"	"G" DIA	"S"	"L"	QTY	PACKAGE TYPE	PART NO

AMP INCORPORATED CUSTOMER SERVICE SYSTEMS		MAX RECOMMENDED OPERATING TEMPERATURE: 150°C MAX	THIS DRAWING IS A CONTROLLED DOCUMENT.		DWN JR RUTH 22JUL05	Tyco Electronics Tyco Electronics Corporation Harrisburg, Pa 17105-3608	
FOR ADDITIONAL PRODUCT INFORMATION OR COPIES OF DRAWINGS AND TECHNICAL DOCUMENTS	PRODUCT INFORMATION CENTER 1-800-522-6752	VOLTAGE RATING: -	DIMENSIONS: INCHES	TOLERANCES UNLESS OTHERWISE SPECIFIED: 0 PLC ± - 1 PLC ± - 2 PLC ± - 3 PLC ± - 4 PLC ± - ANGLES ± -	CHK T MICHELUTTI 22JUL05	NAME T MICHELUTTI	
FOR APPLICATION	TOOLING ASSISTANCE CENTER 1-800-722-1111	CIRCULAR MIL AREA: 0.26-1.65mm² [509-3,260] STRANDED	MATERIAL		APVD T MICHELUTTI 22JUL05	PRODUCT SPEC -	
FOR ORDER ENTRY	1-800-526-5142	THIS DRAWING IS A CONTROLLED DOCUMENT FOR AMP INCORPORATED. IT IS SUBJECT TO CHANGE AND THE CONTROLLING ENGINEERING ORGANIZATION SHOULD BE CONTACTED FOR THE LATEST REVISION.		FINISH -	APPLICATION SPEC -	SIZE A3	CAGE CODE 00779
					WEIGHT -	DRAWING NO C-696422	RESTRICTED TO -
					CUSTOMER DRAWING		SCALE 4:1
							SHEET 1 OF 1
							REV A1

AMP 1470-19 REV 31MAR2000