

LCD Module

Product Specification

: APPROVAL FOR SPECIFICATION

For Customer : _____ : APPROVAL FOR SAMPLE

Module No. : TSM240160F-49B

For Customer's Acceptance :

Approved by	Comment

Team Source Display :

Presented by	Reviewed by	Organized by
		

Table of Content

1. Basic Specifications.....	3
1.1 Display Specifications.....	3
1.2 Mechanical Specifications.....	3
1.3 Circuit Diagram.....	3
1.4 Terminal Function.....	4
2. Absolute Maximum Ratings.....	5
3. Electrical Characteristics.....	5
3.1 DC Characteristics.....	5
3.2 LED Backlight Circuit.....	5
3.3 AC Characteristics.....	6
3.4 Reset Timing.....	7
4. Function specifications.....	8
4.1 The Parallel Interface.....	8
4.2 Basic Setting.....	8
4.3 Resetting the LCD module.....	8
4.4 Display Commands.....	9
4.5 Basic Operating Sequence and 8080 serial interface.....	11
5. Inspection Standards.....	13
6. Handling Precautions.....	14
6.1 Mounting method.....	14
6.2 Cautions of LCD handling and cleaning.....	14
6.3 Caution against static charge.....	14
6.4 Packaging.....	14
6.5 Caution for operation.....	14
6.6 Storage.....	14
6.7 Safety.....	14

1. Basic Specifications

1.1 Display Specifications

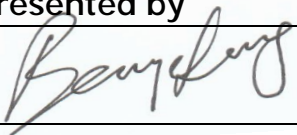
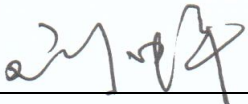
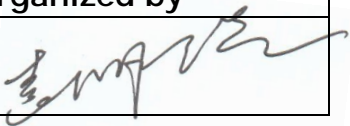
- 1>LCD Display Mode : FSTN-32Gray, Negative, Transmissive
- 2>Viewing Angle : 6H
- 3>Driving Method : 1/160 Duty, 1/12 Bias
- 4 >Backlight :White LED

1.2 Mechanical Specifications

- 1>Outline Dimension : 87.0 x73.0 x 10.0mm (See attached Outline Drawing for Data)

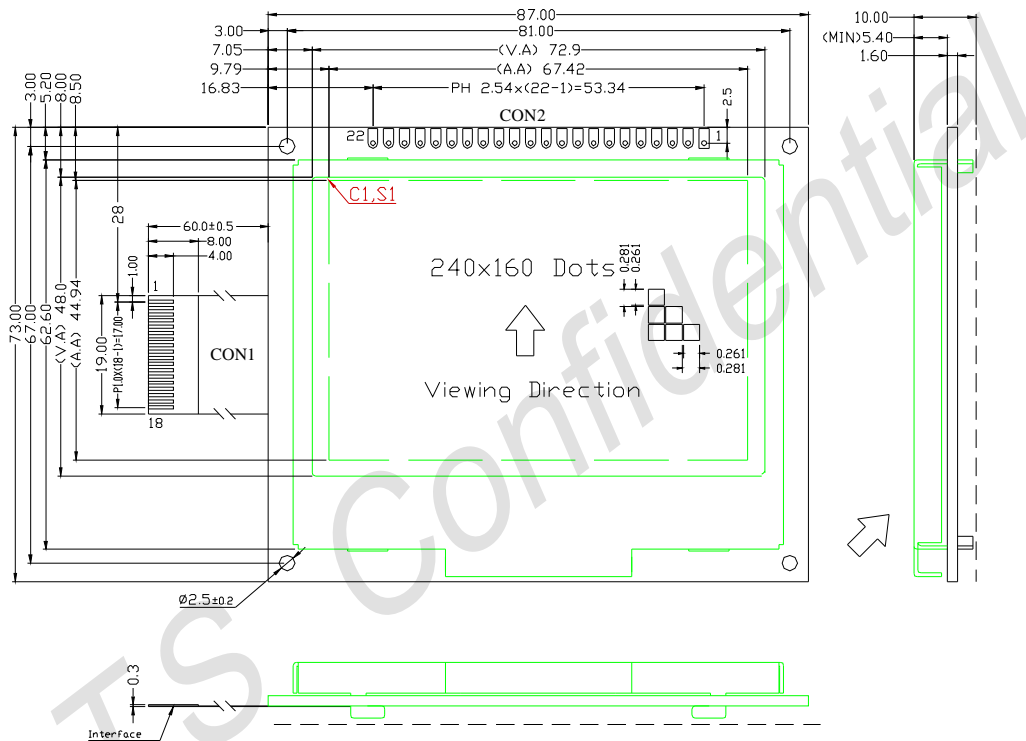

1.3 Circuit Diagram

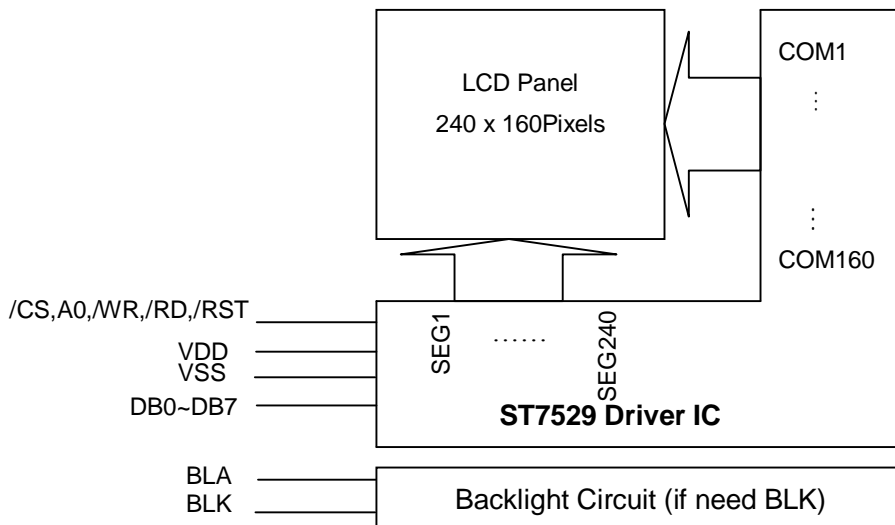

1.4 Terminal Function

1.41 CON1

Pin No.	Pin Name	Function
1	VSS	Negative Power Supply,0V
2	VDD	Power Supply For Logic Circuit 3.3V
3	NC (EN)	VLCD Power Enable(L:Open;H:Close)
4	A0 (RS)	Data/Command Control.
5	/WR	Write (/WR) Control Signal Input.
6	/RD	Read (/RD) Control Signal Input.
7~14	DB0~DB7	8-bit Date bus
15	/CS	Chip Selection Input
16	/RST	Reset Signal
17	BLA (+)	Power Supply For Backlight Positive (3.3V)
18	BLK (-)	Power Supply For Backlight Negative (0V)

1.42 CON2

Pin No.	Pin Name	Function
1	VSS	Power Supply For Logic Circuit ,0V
2	VDD	Power Supply For Logic Circuit 3.3V
3~10	DB0~DB7	8-bit Date Bus
11	/WR	Write (/WR) Control Signal Input.
12	A0(RS)	Data/Command Control.
13	/RD	Read (/RD)Control Signal Input.
14	/RST	Reset Signal
15	/CS	Chip Selection Input
16	NC(EN)	VLCD Power Enable(L:Open;H:Close)
17	BLA (+)	Power Supply For Backlight Positive (3.3V)
18	BLK (-)	Power Supply For Backlight Negative (0V)
19~22	NC	

2. Absolute Maximum Ratings

Items	Symbol	MIN.	MAX.	Unit	Condition
Supply Voltage	V _{DD}	V _{SS}	+3.3	V	V _{SS} = 0V
Input Voltage	V _{IN}	V _{SS}	V _{DD} +0.3	V	V _{SS} = 0V
Operating Temperature	T _{OP}	-20	+70	°C	No Condensation
Storage Temperature	T _{st}	-25	+80	°C	No Condensation

3. Electrical Characteristics

3.1 DC Characteristics

V_{SS} = 0V, Top = 25°C

Items	Symbol	MIN.	TYP.	MAX.	Unit	Condition
Operating Voltage	V _{DD}	2.4	-	3.3	V	V _{DD}
Input High Voltage	V _{IH}	0.7 x V _{DD}	-	V _{DD}	V	/CS1,/RES,A0,/WR,
Input Low Voltage	V _{IL}	V _{SS}	-	0.3 x V _{DD}	V	E,D0~D7
Output High Voltage	V _{OH}	0.7 x V _{DD}	-	V _{DD}	V	D0~D7
Output Low Voltage	V _{OL}	V _{SS}	-	0.3 x V _{DD}	V	D0~D7
Input Leakage Current	I _{LI}	-1.0	-	1.0	μA	V _{DD}
Output Leakage Current	I _{Lo}	-	-	-	μA	V _{DD}

3.2 LED Backlight Circuit (if need BLK)

V_{SS} = 0V, Top = 25°C

Items	Symbol	MIN.	TYP.	MAX.	Unit	Condition
Forward Voltage	V _f BLA	-	3.3	-	V	V _{DD}
Forward Current	I _f BLA	-	48	60	mA	V _{DD}

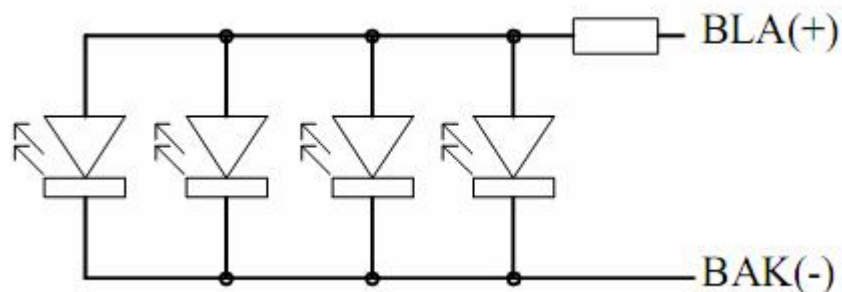

3.3 AC Characteristics

8080 Mode System Bus Timing

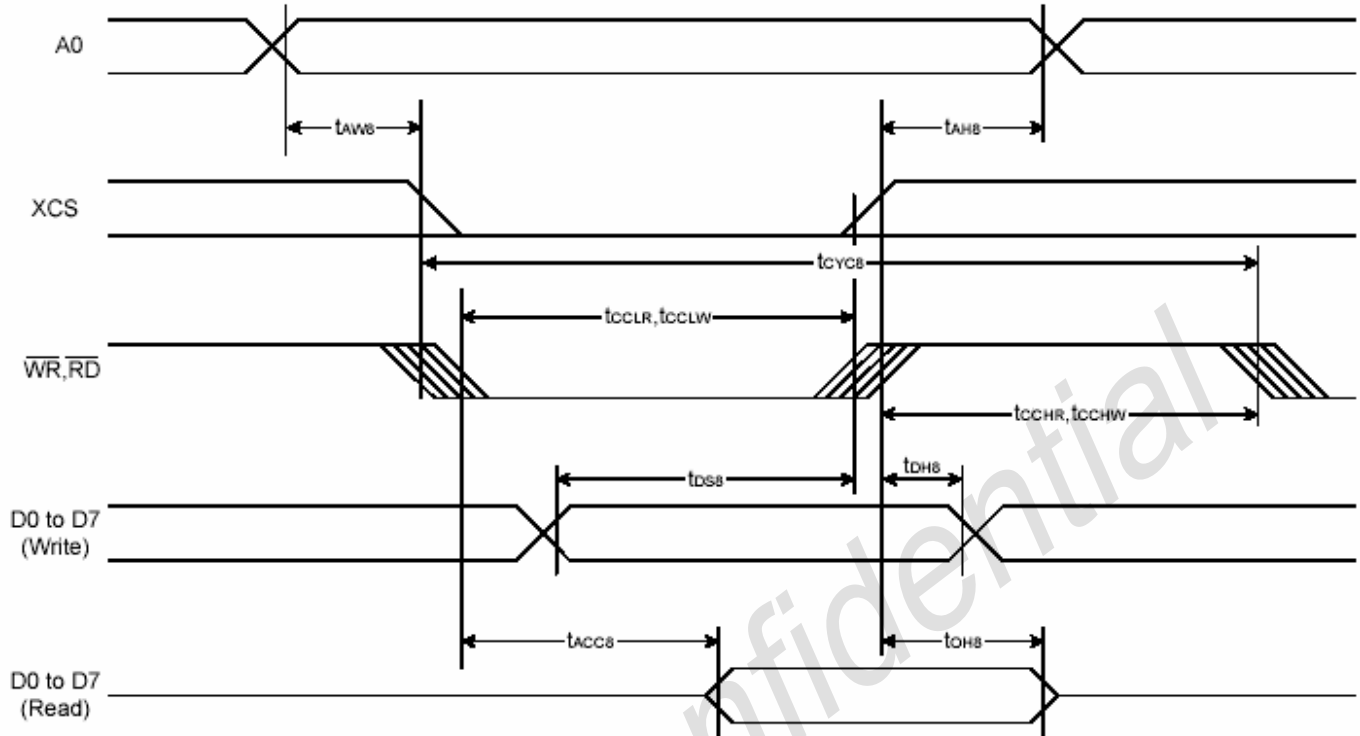

$V_{dd} = 3.3V, T_a = -40-85^{\circ}C$

Items	Symbol	MIN.	TYP.	MAX.	Unit	Condition
System cycle time	T_{cyc8}	200	-	-	ns	-
Address setup time(A0)	T_{aw8}	20	-	-	ns	-
Address hold time(A0)	T_{ah8}	20	-	-	ns	-
Control Low Pulse wide(/RD)	t_{cclr}	100	-	-	ns	-
Control Low Pulse wide(/WR)	t_{cclw}	100	-	-	ns	-
Control High Pulse wide(/RD)	t_{cchr}	100	-	-	ns	-
Control High Pulse wide(/WR)	t_{cchw}	100	-	-	ns	-
Data setup time	T_{ds8}	150	-	-	ns	-
Data hold time	T_{dh8}	20	-	-	ns	-
/RD access time(*a)	T_{acc8}	-	-	40	ns	-
Output disable time(*a) %	T_{ch8}	15	-	30	ns	-

Note:

*a. all timing is using 20 and 80 of VDD as the reference

3.4 Reset Timing

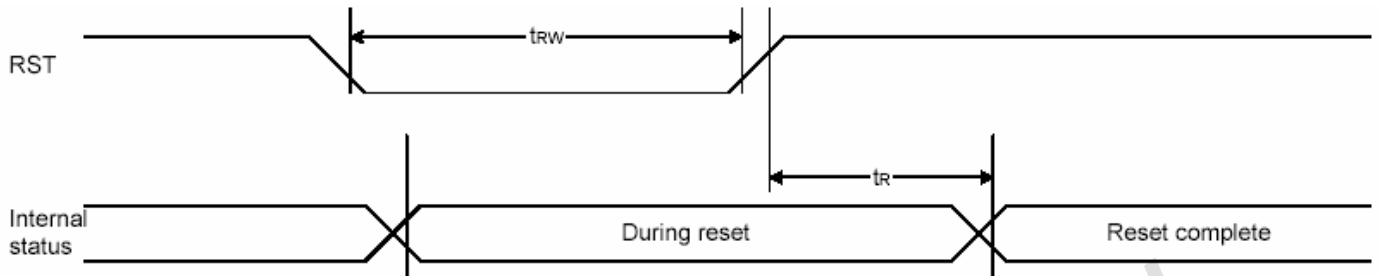

(VDD=3.3V, Ta=-40-85°C)

Items	Symbol	MIN.	TYP.	MAX.	Unit	Condition
Reset time	Tr	-	-	1	μ S	-
Reset Low pules width	Trw	1	-	-	μ S	-

(VDD=2.7V, Ta=-40-85°C)

Items	Symbol	MIN.	TYP.	MAX.	Unit	Condition
Reset time	Tr	-	-	1.5	μ S	-
Reset Low pules width	Trw	1.5	-	-	μ S	-

Note:

*a. all timing is using 20 and 80 of VDD as the reference.

4. Function specifications

4.1 The Parallel Interface

Shared			8080 Mode		Function
/RST	/CS	A0	/RD	/WR	
H	L	H	L à H	L	Read display data
H	L	H	H	L à H	Write display data
H	L	L	L à H	L	Staus read
H	L	L	H	L à H	Write Command

4.2 Basic Setting

To drive the LCD module correctly and provide normally display, please use the following seting

- 1> COM Reverse Select = 0x00 (Normal. Or 0x01 Up and Down Reverse)
- 2> SEG Reverse Select = 0x00 (Normal. Or 0x02, Left and Right Reverse)
- 3> SEG And COM Reverse Select = 0x03
- 4> RGB Order = 0x00 (Normal, Or 0x01 If Left and Right Reversed)

4.3 Resetting the LCD module

The LCD module should be initialized by using /RST terminal.

While turning on the VDD and VSS power supply, maintain /RST terminal at LOW level, After the Power supply stabilized, release the reset terminal(/RST = High)

4.4 Display Commands

Ext=0 or Ext=1

Index	Command	A0	RD	WR	D7	D6	D5	D4	D3	D2	D1	D0	Function	Hex	Parameter
1	Ext In	0	1	0	0	0	1	1	0	0	0	0	Ext=0 Set	30	None
2	Ext Out	0	1	0	0	0	1	1	0	0	0	1	Ext=1 Set	31	None

Ext=0

Index	Command	A0	RD	WR	D7	D6	D5	D4	D3	D2	D1	D0	Function	Hex	Parameter
1	DISON	0	1	0	1	0	1	0	1	1	1	1	Display On	AF	None
2	DISOFF	0	1	0	1	0	1	0	1	1	1	0	Display Off	AE	None
3	DISNOR	0	1	0	1	0	1	0	0	1	1	0	Normal Display	A6	None
4	DISINV	0	1	0	1	0	1	0	0	1	1	1	Inverse Display	A7	None
5	COMSCN	0	1	0	1	0	1	1	1	0	1	1	COM Scan Direction	BB	1 byte
6	DISCTRL	0	1	0	1	1	0	0	1	0	1	0	Display Control	CA	3 bytes
7	SLPIN	0	1	0	1	0	0	1	0	1	0	1	Sleep In	95	None
8	SLPOUT	0	1	0	1	0	0	1	0	1	0	0	Sleep Out	94	None
9	LASET	0	1	0	0	1	1	1	0	1	0	1	Line Address Set	75	2 bytes
10	CASET	0	1	0	0	0	0	1	0	1	0	1	Column Address Set	15	2 bytes
11	DATSDR	0	1	0	1	0	1	1	1	1	0	0	Data Scan Direction	BC	3 bytes
12	RAMWR	0	1	0	0	1	0	1	1	1	0	0	Writing to Memory	5C	Data
13	RAMRD	0	1	0	0	1	0	1	1	1	0	1	Reading from Memory	5D	Data
14	PTLIN	0	1	0	1	0	1	0	1	0	0	0	Partial display in	A8	2 bytes
15	PTLOUT	0	1	0	1	0	1	0	1	0	0	1	Partial display out	A9	None
16	RMWIN	0	1	0	1	1	1	0	0	0	0	0	Read and Modify Write	E0	None
17	RMWOUT	0	1	0	1	1	1	0	1	1	1	0	RMW end	EE	None
18	ASCSET	0	1	0	1	0	1	0	1	0	1	0	Area Scroll Set	AA	4 bytes
19	SCSTART	0	1	0	1	0	1	0	1	0	1	1	Scroll Start Set	AB	1 byte
20	OSCON	0	1	0	1	1	0	1	0	0	0	1	Internal OSC on	D1	None
21	OSCOFF	0	1	0	1	1	0	1	0	0	1	0	Internal OSC off	D2	None
22	PWRCTRL	0	1	0	0	0	1	0	0	0	0	0	Power Control	20	1 byte
23	VOLCTRL	0	1	0	1	0	0	0	0	0	0	1	EC control	81	2 bytes
24	VOLUP	0	1	0	1	1	0	1	0	1	1	0	EC increase 1	D6	None
25	VOLDOWN	0	1	0	1	1	0	1	0	1	1	1	EC decrease 1	D7	None
26	RESERVED	0	1	0	1	0	0	0	0	0	1	0	Not Use	82	0
27	EPSRRD1	0	1	0	0	1	1	1	1	1	0	0	READ Register1	7C	None

28	EPSRRD2	0	1	0	0	1	1	1	1	1	0	1	READ Register2	7D	None
29	NOP	0	1	0	0	0	1	0	0	1	0	1	NOP Instruction	25	None
30	STREAD	0	0	1	Read Data							Status Read			

Ext=1

Index	Command	A0	RD	WR	D7	D6	D5	D4	D3	D2	D1	D0	Function	Hex	Parameter
1	Gray 1 Set	0	1	0	0	0	1	0	0	0	0	0	FRAME 1 Gray PWM Set	20	16 bytes
2	Gray 2 Set	0	1	0	0	0	1	0	0	0	0	1	FRAME 2 Gray PWM Set	21	16 bytes
3	Wt. Set	0	1	0	0	0	1	0	0	0	1	0	Weight Set	22	3 bytes
4	ANASET	0	1	0	0	0	1	1	0	0	1	0	Analog Circuit Set	32	3 bytes
5	DITHOFF	0	1	0	0	0	1	1	0	1	0	0	Dithering Circuit Off	34	None
6	DITHON	0	1	0	0	0	1	1	0	1	0	1	Dithering Circuit On	35	None
7	EPCTIN	0	1	0	1	1	0	0	1	1	0	1	Control EEPROM	CD	1 byte
8	EPCOUT	0	1	0	1	1	0	0	1	1	0	0	Cancel EEPROM	CC	None
9	EPMWR	0	1	0	1	1	1	1	1	1	0	0	Write to EEPROM	FC	None
10	EPMRD	0	1	0	1	1	1	1	1	1	0	1	Read from EEPROM	FD	None

Note:

*a. For the details of the Display Commands, please refer to ST7529 data sheet

4.5 Basic Operating Sequence

4.5.1 Initialization Sequence

	Code Function										Note	
	A0	D7	D6	D5	D4	D3	D2	D1	D0	hex		
Turn on Power Supply VDD & VSS While maintaining /RES at LOW	-	-	-	-	-	-	-	-	-	-	-	
Wait until power supply is stabilized	-	-	-	-	-	-	-	-	-	-	-	
Release the /RES Reset Signal (/RES = High)	-	-	-	-	-	-	-	-	-	-		
EXT=Use the "ext=0" Command	0	1	0	1	0	0	0	1	1	30H	EXT=0	
Sleep Out	0	1	0	0	1	0	1	0	0	94H	Sleep Out	
Osc on	0	1	1	0	1	0	0	1	0	D2H		
Com scan dtrec 0-65/160-66	0 1	0 0	1 0	0 0	0 0	0 0	0 0	0 0	0 1	BBH 01H		
Display Control CL Dividin ratio=0 Duty=1/12 FR inverse-set value EXT=Use the "ext=0" Command	0 1 1 0	1 0 0 0	1 0 0 1	0 0 0 0	0 0 0 0	1 0 0 0	0 1 0 0	1 0 0 1	0 1 0 1	CAH 04H 27H 00H		
00011000000101 Analogl Osc freq Booster effc Bise	0 1 1 1	0 0 0 0	0 0 0 0	1 0 0 0	0 0 0 0	0 0 0 0	0 0 0 0	0 1 1 0	0 0 1 0	32H 03H 00H 02H		
EXT=Use the "ext=0" Command EC contral Vop[5:0] Vop[8:6]	0 0 1 1	0 1 0 0	0 0 1 0	1 0 1 0	0 0 1 0	0 0 0 0	0 0 0 0	0 0 1 1	1 0 0 0	30H 81H 30H 03H		
Power contral D0 = regulator / D1 = follwer / D3 = booster	0 1	0 0	0 0	0 0	1 0	0 1	0 0	0 1	0 1	20H 0BH		
Close auto sampling	0	1	0	1	0	1	1	1	1	60H		
inverse display	0	1	0	1	0	0	1	1	1	A7H		
data scan direc. C/L com/line,ci,li:address scan direc. ----- Gray scale Exite the partial display mode display on	0 1 1 0 0 0	1 0 0 0 1 0	0 0 0 0 1 0	1 0 0 0 1 0	1 0 0 1 1 1	1 0 0 1 1 1	0 0 0 0 0 0	0 0 1 0 1 1	0 0 0 1 1 0	BCH 00H 00H 02H A9H AFH		
EXT-0 Column address set PB1 PB2 Line address set PB1 PB2	0 0 1 1 0 1	0 0 X X 1 X	0 0 X X X X	1 0 X X 1 X	0 1 X X 0 X	0 1 X X 1 X	0 1 X X 0 X	0 1 X X 1 X	0 1 X X 0 X	30H 15H PB1 PB2 75H PB1 PB2	Start column End coulmn	
Data	1										8 bit data	

4.5.2 8080serial 8-bit Inteface

FPC上的接口顺序 5倍压连接图，有参考程序

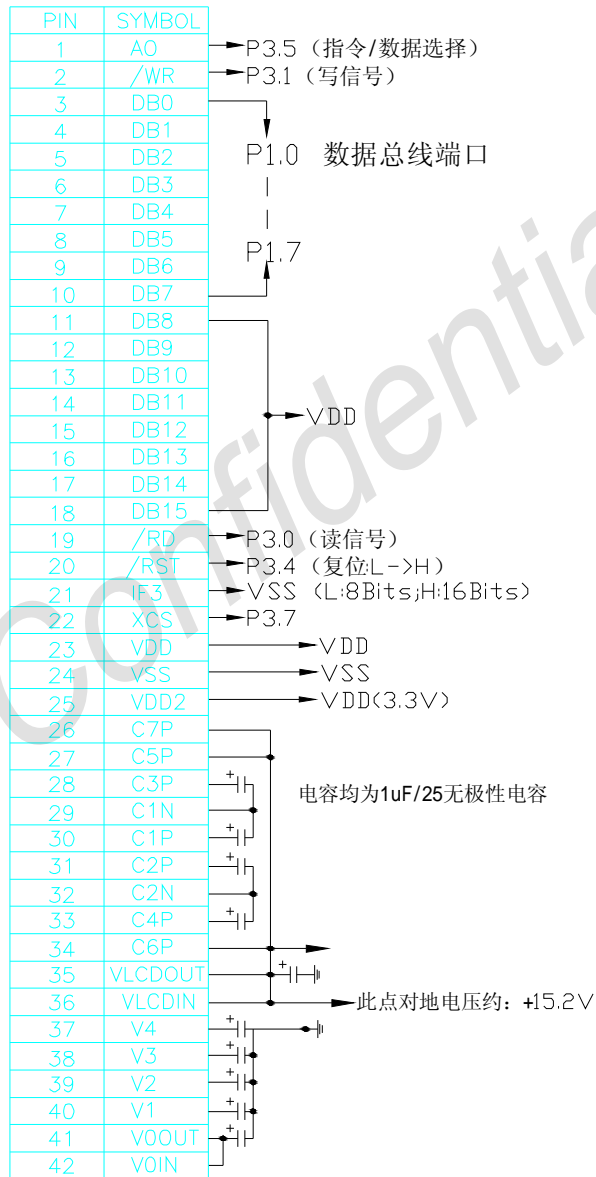

IF3	8080 system
H	16 Bits
L	8 Bits

说明: 上图为内部升压参考电路, 但建议用外部升压电路!
 外部升压时, 28~33脚悬空, 且36脚与35脚断开后,
 36脚外接驱动电压15.5V左右

5. Inspection Standards

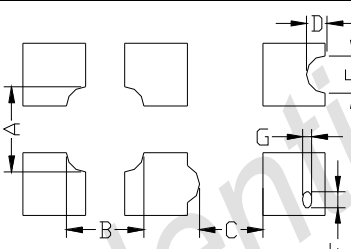
Item	Criterion for defects	Defect type
1) Display on inspection	(1) Non display (2) Vertical line is deficient (3) Horizontal line is deficient (4) Cross line is deficient	Major
2) Black / White spot	Size Φ (mm) Acceptable number $\Phi \leq 0.3$ Ignore (note) $0.3 < \Phi \leq 0.45$ 3 $0.45 < \Phi \leq 0.6$ 1 $0.6 < \Phi$ 0	Minor
3) Black / White line	Length (mm) Width (mm) Acceptable number $L \leq 10$ $W \leq 0.03$ Ignore $5.0 \leq L \leq 10$ $0.03 < W \leq 0.04$ 3 $5.0 \leq L \leq 10$ $0.04 < W \leq 0.05$ 2 $1.0 \leq L \leq 10$ $0.05 < W \leq 0.06$ 2 $1.0 \leq L \leq 10$ $0.06 < W \leq 0.08$ 1 $L \leq 10$ $0.08 < W$ follows 2) point defect Defects separate with each other at an interval of more than 20mm	Minor
4) Display pattern	 $\frac{A+B \leq 0.28}{2}$ $0 < C$ $\frac{D+E \leq 0.25}{2}$ $\frac{F+G \leq 0.25}{2}$ Note: 1) Up to 3 damages acceptable 2) Not allowed if there are two or more pinholes every three-fourth inch.	Minor
5) Spot-like contrast irregularity	Size Φ (mm) Acceptable Number $\Phi \leq 0.7$ Ignore (note) $0.7 < \Phi \leq 1.0$ 3 $1.0 < \Phi \leq 1.5$ 1 $1.5 < \Phi$ 0 Note: 1) Conformed to limit samples. 2) Intervals of defects are more than 30mm.	Minor
6) Bubbles in polarizer	Size Φ (mm) Acceptable Number $\Phi \leq 0.4$ Ignore (note) $0.4 < \Phi \leq 0.65$ 2 $0.65 < \Phi \leq 1.2$ 1 $1.2 < \Phi$ 0	Minor
7) Scratches and dent on the polarizer	Scratches and dent on the polarizer shall be in the accordance with "2) Black/white spot", and "3) Black/White line".	Minor
8) Stains on the surface of LCD panel	Stains which cannot be removed even when wiped lightly with a soft cloth or similar cleaning.	Minor
9) Rainbow color	No rainbow color is allowed in the optimum contrast on state within the active area.	Minor
10) Viewing area encroachment	Polarizer edge or line is visible in the opening viewing area due to polarizer shortness or sealing line.	Minor
11) Bezel appearance	Rust and deep damages that are visible in the bezel are rejected.	Minor
12) Defect of land surface contact	Evident crevices that are visible are rejected.	Minor
13) Parts mounting	(1) Failure to mount parts (2) Parts not in the specifications are mounted (3) For example: Polarity is reversed, HSC or TCP falls off.	Minor
14) Part alignment	(1) LSI, IC lead width is more than 50% beyond pad outline. (2) More than 50% of LSI, IC leads is off the pad outline.	Minor
15) Conductive foreign matter (solder ball, solder hips)	(1) $0.45 < \Phi$, $N \geq 1$ (2) $0.3 < \Phi \leq 0.45$, $N \geq 1$, Φ : Average diameter of solder ball (unit: mm) (3) $0.5 < L$, $N \geq 1$, L : Average length of solder chip (unit: mm)	Minor
16) Bezel flaw	Bezel claw missing or not bent	Minor
17) Indication on name plate (sampling indication label)	(1) Failure to stamp or label error, or not legible.(all acceptable if legible) (2) The separation is more than 1/3 for indication discoloration, in which the characters can be checked.	Minor

6. Handling Precautions

6.1 Mounting method

A panel of LCD module made by our company consists of two thin glass plates with polarizers that easily get damaged. And since the module is so constructed as to be fixed by utilizing fitting holes in the printed circuit board (PCB), extreme care should be used when handling the LCD modules.

6.2 Cautions of LCD handling and cleaning

When cleaning the display surface, use soft cloth with solvent (recommended below) and wipe lightly.

- Isopropyl alcohol
- Ethyl alcohol
- Trichlorotrifluoroethane

Do not wipe the display surface with dry or hard materials that will damage the polarizer surface.

Do not use the following solvent:

- Water
- Ketene
- Aromatics

6.3 Caution against static charge

The LCD module uses C-MOS LSI drivers. So we recommend you:

Connect any unused input terminal to V_{dd} or V_{ss} . Do not input any signals before power is turned on, and ground your body, work/assembly areas, assembly equipment to protect against static electricity.

6.4 Packaging

- Module employs LCD elements, and must be treated as such. Avoid intense shock and falls from a height.
- To prevent modules from degradation, do not operate or store them exposed direct to sunshine or high temperature/humidity.

6.5 Caution for operation

-It is an indispensable condition to drive LCD module within the limits of the specified voltage since the higher voltage over the limits may cause the shorter life of LCD module.

-An electrochemical reaction due to DC (direct current) causes LCD undesirable deterioration so that the uses of DC (direct current) drive should be avoided.

-Response time will be extremely delayed at lower temperature than the operating temperature range and on the other hand at higher temperature LCD module may show dark color in them. However those phenomena do not mean malfunction or out of order of LCD module, which will come back in the specified operating temperature.

6.6 Storage

In the case of storing for a long period of time, the following ways are recommended:

- Storage in polyethylene bag with the opening sealed so as not to enter fresh air outside in it. And with not desiccant.
- Placing in a dark place where neither exposure to direct sunlight nor light is. Keeping the storage temperature range.
- Storing with no touch on polarizer surface by any thing else.

6.7 Safety

-It is recommendable to crash damaged or unnecessary LCD into pieces and to wash off liquid crystal by either of solvents such as acetone and ethanol, which should be burned up later.

-When any liquid leaked out of a damaged glass cell comes in contact with your hands, please wash it off well at once with soap and water.