

FEATURES

- Input Voltage : 3V to 20V
- Output Voltage : 3.3V to 32V
- Duty Ratio : 0% to 85% PWM Control
- Oscillation Frequency : 500KHz.
- Enable and Thermal Shutdown Function.
- Internal Current Limit.
- Built-in N-channel MOSFET
- ESOP-8 & Pb-Free Package.

DESCRIPTION

The APE1911 is high efficient step-up DC/DC converter. Large output current is possible having a built in internal N channel MOSFET, and using an external coil and diode.

The APE1911 can be operated at switching frequencies of 500 kHz allowing for easy filtering and low noise, the size of the external components can be reduced.

Output voltage is programmable with 1.0V of standard voltage supply internal, and using externally connected components, output voltage (FB) can be set up at will. The soft-start time can be programmed by outside capacitor; the function prevents overshoot at startup. Build inside Current limit, Thermal Shutdown and enable functions.

TYPICAL APPLICATION

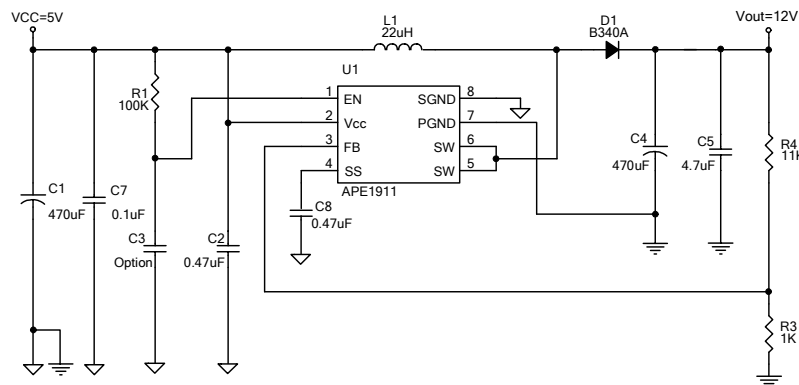

$$V_{OUT} = V_{FB} \times (1 + R4/R3), V_{FB} = 1.0V, R3 = 1K \sim 3K\Omega$$

PACKAGE & ORDERING INFORMATION

APE1911X

Package Type
MP : ESOP-8

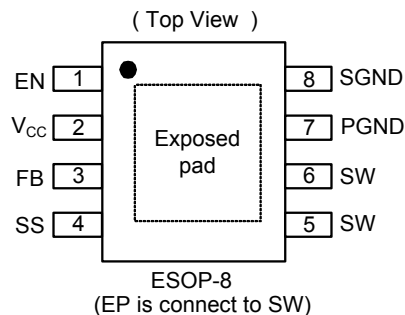



ABSOLUTE MAXIMUM RATINGS

VCC Pin Voltage (V_{CC})	GND - 0.3V to GND + 22V
Feedback Pin Voltage (V_{FB})	GND - 0.3V to 6V
ON/OFF Pin Voltage (V_{EN})	GND - 0.3V to VCC
Switch Pin Voltage (V_{SW})	GND - 0.3V to 34V
SS Pin Voltage (V_{SS})	GND - 0.3V to 6V
Power Dissipation (PD)	Internally limited
Storage Temperature Range (T_{ST})	-40°C to +150°C
Operating Junction Temperature (T_{OPJ})	-20°C to +125°C
Thermal Resistance from Junction to Case(R_{thJC})	15°C/W
Thermal Resistance from Junction to Ambient(R_{thJA})	40°C/W

Note. R_{thJA} is measured with the PCB copper area (connect to exposed pad) of approximately 1 in²(Multi-layer).

ELECTRICAL SPECIFICATIONS

($V_{IN}=5V$, $V_{OUT}=12V$, $T_A=25^\circ C$, unless otherwise specified)

Parameter	SYM	TEST CONDITION	MIN	TYP	MAX	UNITS
Operating Supply Voltage	V_{CC}		3	-	20	V
Output Voltage Range	V_{OUT}		3.3	-	32	V
Feedback Voltage	V_{FB}	$I_{OUT}=0.1A$	0.98	1	1.02	V
Feedback Bias Current	I_{FB}	$I_{OUT}=0.1A$	-	0.1	0.5	uA
Quiescent Current	I_{CCQ}	$V_{FB}=1.5V$ force driver off	-	4	6	mA
Shutdown Supply Current	I_{SD}	$V_{EN}=0V$	-	1	10	uA
Oscillation Frequency	F_{OSC}	SW pin	400	500	600	KHz
Line Regulation		$V_{CC}=3\sim 0.8*V_{out}$	-	1	-	%
Load Regulation		$I_{OUT}=50m\sim 1A$	-	1	-	%
EN Pin Logic input threshold voltage	V_{SH}	High (regulator ON)	2	-	-	V
	V_{SL}	Low (regulator OFF)	-	-	0.8	
EN Pin Input Current	I_{SH}	$V_{EN}=2.5V$ (ON)	-	20	-	uA
	I_{SL}	$V_{EN}=0.3V$ (OFF)	-	-1	-	uA
SS pin Current	I_{SS}		-	8	-	uA
Switching Current Limit	I_{LIM-sw}		2.8	3	-	A
Internal MOSFET $R_{DS(on)}$	$R_{DS(on)}$	$V_{CC}=5V$	-	40	80	mΩ
		$V_{CC}=12V$	-	30	60	
Efficiency	EFFI	$V_{CC}=5V$, $V_{OUT}=12V$, $I_{OUT}=0.5A$	-	92	-	%
Maximum Duty Cycle	DC_{MAX}	$V_{FB}=0V$	-	85	-	%
Minimum Duty Cycle	DC_{MIN}	$V_{FB}=1.5V$	-	0	-	
Thermal Shutdown Temp	TSD		-	145	-	°C



PIN DESCRIPTIONS

PIN SYMBOL	PIN DESCRIPTION
VCC	IC Power Supply Pin
SW	Switch pin. Connect external inductor & diode here
FB	Feedback Pin
EN	Shutdown Pin
	H : Normal operation
	L : Shutdown
SS	Soft-Start Pin.
PGND	Power Ground pin
SGND	Signal Ground pin.

BLOCK DIAGRAM

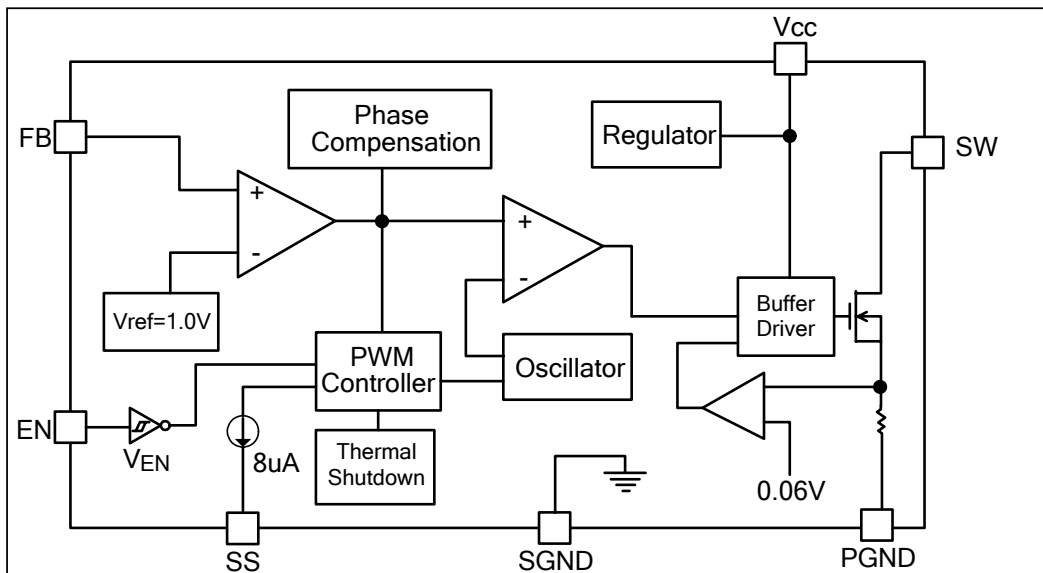



FUNCTION DESCRIPTION

PWM Control

The APE1911 consists of DC/DC converters that employ a pulse-width modulation (PWM) system. In converters of the APE1911, the pulse width varies in a range from 0 to 85%, according to the load current. The ripple voltage produced by the switching can easily be removed through a filter because the switching frequency remains constant. Therefore, these converters provide a low-ripple power over broad ranges of input voltage and load current.

Setting the Output Voltage

Application circuit item shows the basic application circuit with APE1911 adjustable output version. The external resistor sets the output voltage according to the following equation:

$$V_{OUT} = 1.0V \times (1+R4/R3)$$

Table 1 Resistor select for output voltage setting

V _{OUT}	R3	R4
12V	1K	11K
15V	1.3K	18K
18V	1.3K	22K
24V	1.3K	30K
32V	2.2K	68K

Inductor Selection

For most designs, Low inductance values are physically smaller but require faster switching, which results in some efficiency loss. The inductor value can be derived from the following equation:

$$L = [V_{IN} \times (V_{OUT}-V_{IN})] / V_{OUT} \times \Delta I_L \times f_{Lx}$$

Where is inductor Ripple Current. Large value inductors lower ripple current and small value inductors result in high ripple currents. Choose inductor ripple current approximately 15% of the maximum input current 2.4A, $\Delta I_L=0.18A$.

V _{OUT}	9V	12V	15V	18V
L1 Value	18uH	22uH	25uH	33uH

The DC current rating of the inductor should be at least equal to the maximum load current plus half the ripple current to prevent core saturation (2.4A+0.18A).

Input Capacitor Selection

The input capacitor reduces the surge current drawn from the input and switching noise from the device. The input capacitor impedance at the switching frequency shall be less than input source impedance to prevent high frequency switching current passing to the input. A low ESR input capacitor sized for maximum RMS current must be used.

The capacitor voltage rating should be at least 1.5 times greater than the input voltage, and often much higher voltage ratings are needed to satisfy.



FUNCTION DESCRIPTION

Output Capacitor Selection

The output capacitor is required to keep the output voltage ripple small and to ensure regulation loop stability. The output capacitor must have low impedance at the switching frequency. A low ESR capacitor sized for maximum RMS current must be used. The low ESR requirements needed for low output ripple voltage.

The capacitor voltage rating should be at least 1.5 times greater than the input voltage, and often much higher voltage ratings are needed to satisfy.

Output Capacitor Selection

When laying out the PC board, the following suggestions should be taken to ensure proper operation of the APE1911. These items are also illustrated graphically in below.

1. The power traces, including the Source trace, the Schottky and the C1 trace should be kept short, direct and wide to allow large current flow.
2. The power ground is keep C4's ground closed and far away signal ground.
3. The signal ground trance is distant from power ground trance.
4. The exposed pad is connecting to SW trace closely and widely. (Reduce IC temperature)
5. Do not trace signal line under inductor.

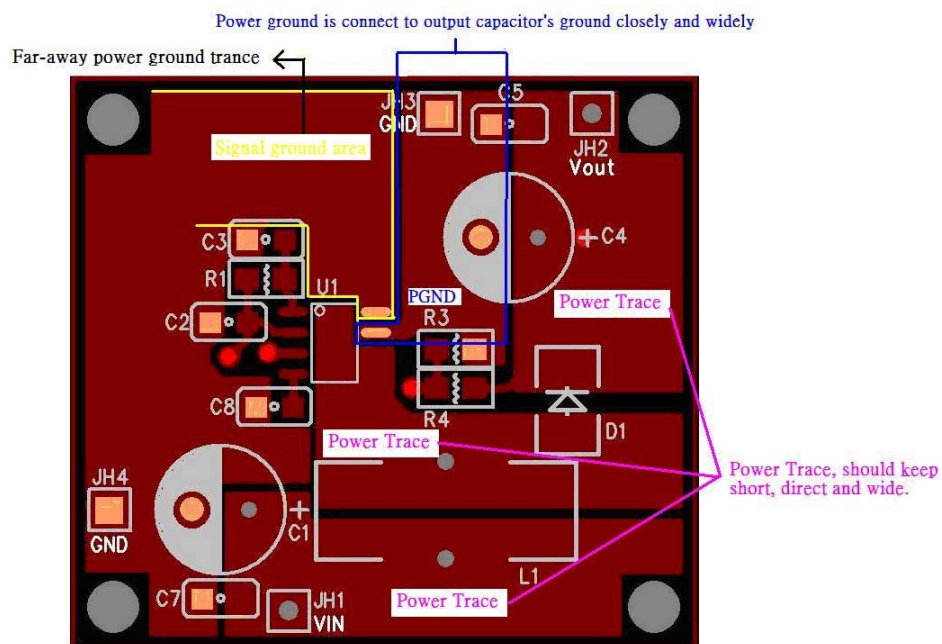

(APE1911 PCB Layout -Top View)



TYPICAL PERFORMANCE CHARACTERISTICS

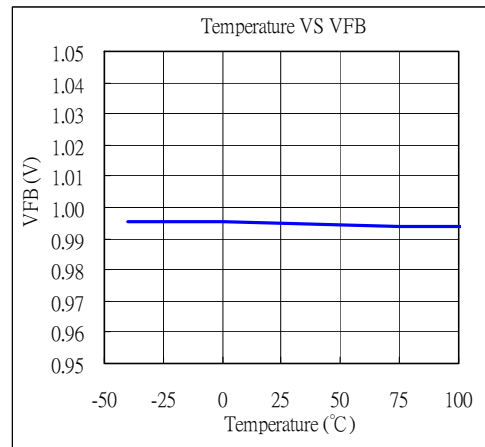
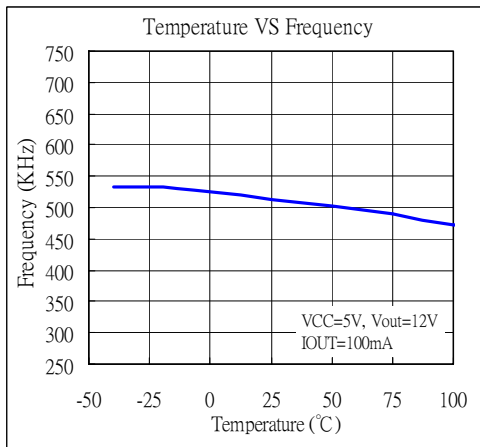
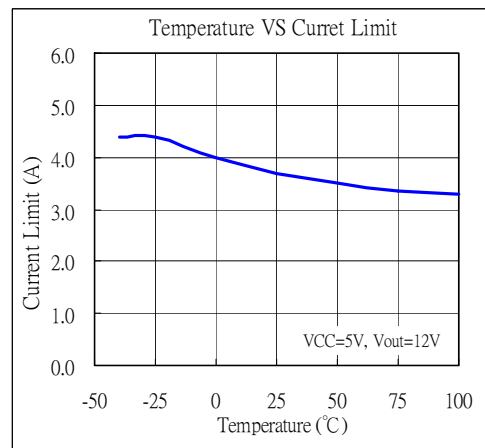
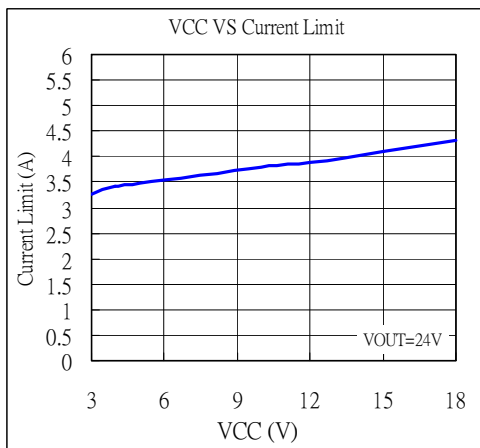
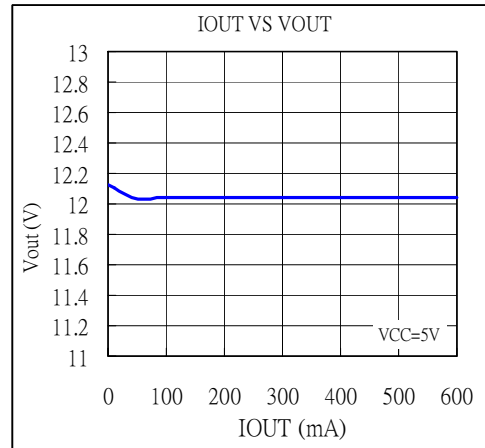
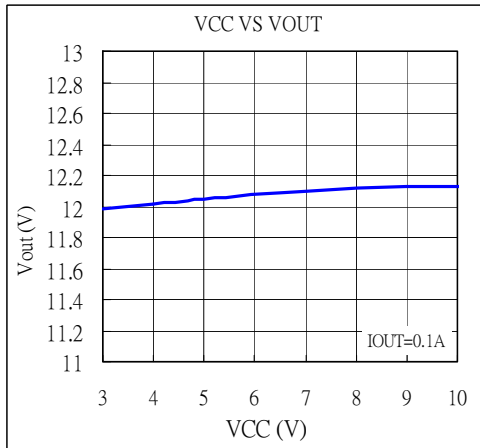



TYPICAL PERFORMANCE CHARACTERISTICS

Power-ON Wave

(VCC=5V, Vout=12V, Load=0.8A, SS=0.47uF)

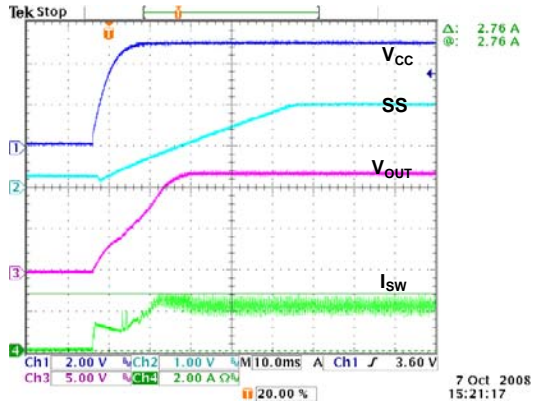

7 Oct 2008
15:21:17

Enable-ON Wave

(VCC=5V, Vout=12V, Load=0.8A, SS=0.47uF)

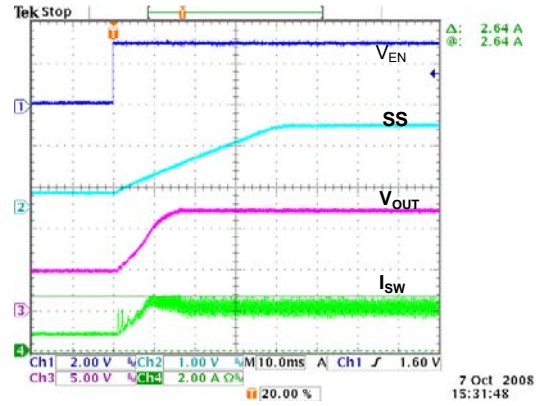

7 Oct 2008
15:31:48



Package Outline : ESOP-8

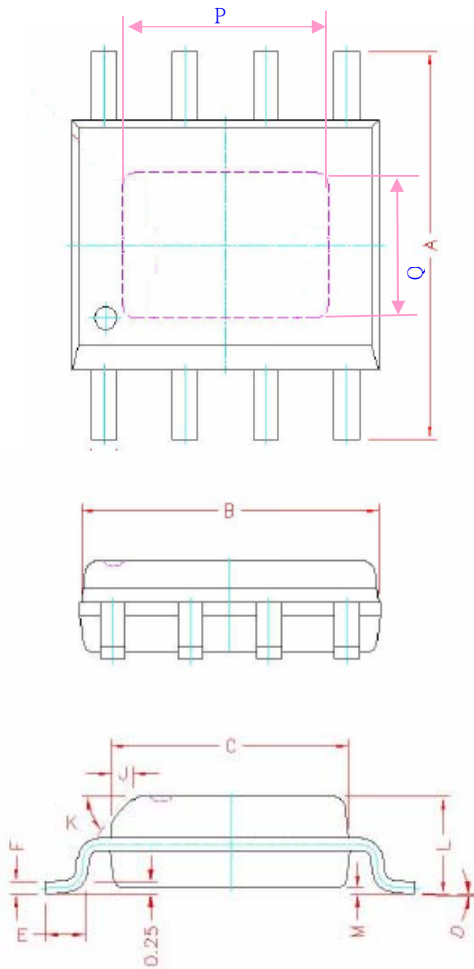

SYMBOLS	Millimeters		
	MIN	NOM	MAX
A	5.80	6.00	6.20
B	4.80	4.90	5.00
C	3.80	3.90	4.00
D	0°	4°	8°
E	0.40	0.65	0.90
F	0.19	0.22	0.25
M	0.00	0.08	0.15
H	0.35	0.42	0.49
L	1.35	1.55	1.75
J	0.375 REF.		
K	45°		
G	1.27 TYP.		
P	3.15	3.25	3.35
Q	2.25	2.35	2.45

- 1.All Dimension Are In Millimeters.
- 2.Dimension Does Not Include Mold Protrusions.

Part Marking Information & Packing : ESOP-8

