

DRAWING MADE IN AMERICAN PROJECTION

© 1970 BY AMP INCORPORATED. ALL RIGHTS RESERVED. AMP PRODUCTS COVERED BY PATENTS AND/OR PATENTS PENDING.

UNPRODUCED WITHOUT WRITTEN PERMISSION OF AMP INCORPORATED.

ZONE	LTR	DESCRIPTION	DATE	APPROVED
	O	NPS 70-0118 (REV2) & 70-0834 (REV1)	12-8-70	FCY
	A	REVISED P-6601	6-18-71	FCY
	B	REV PER ECN PC-5578	10-6-72	JML
	C	REVISED P-6954	12-11-72	JML
	D	REVISED G-3044	4-12-88	BY
	E	OBSOLETE - 2 PER G-3789	11/11/88	AG
	F	OBS. 52431 PER G-3999	1-16-89	LY
	G	REV PER G-5648	11/31/91	DRS/TMB
	H	REV/ O G 10-0058-98	23 APR 98	M6/TM

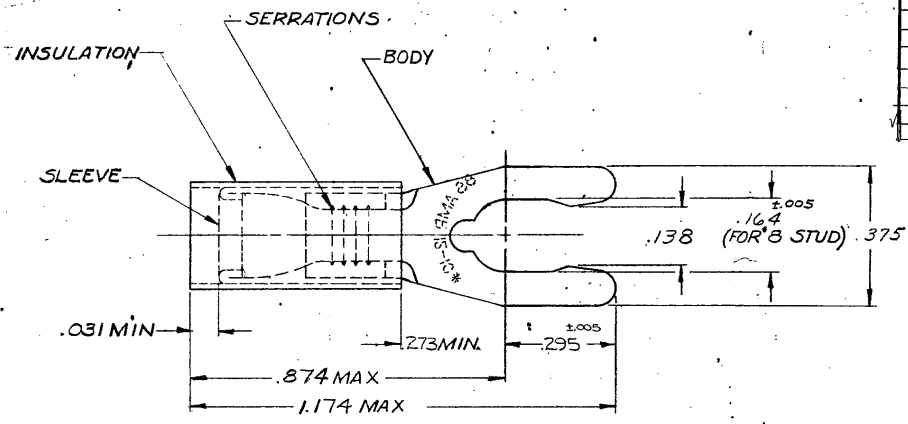

FOR WIRE INS. DIA (SEE TABLE II)  
TONGUE MATERIAL THK .0385 ± .0020

TABLE I

50	Loose Pc. Box	8-52431-2	INSULATION: NYLON COLOR: YELLOW
1	WIRE TERMINAL	SEE TABLE II	SLEEVE: COPPER (ASTM B152)
			BODY: PHOSPHOR BRONZE (ASTM B139)
			TIN PL (ASTM B545)
QTY	DESCRIPTION	PART NO.	MATERIAL & FINISH
UNLESS OTHERWISE SPECIFIED DIMENSIONS ARE IN INCHES TOLERANCES ON DECIMALS ± .008 ANGLES ± 5°		CONTRACT NO. 4	AMP INCORPORATED HARRISBURG, PENNSYLVANIA
MATERIAL		DR. M. Emmerich 12-5-70	NAME WIRE TERMINAL
SEE TABLE I		CHK. R. J. Miller 12-18-70	P.I.D.G.-SPRING SPADE
		APPD. Swartzel 12-10-70	WIRE SIZE: 12-10
		REL. Hysing 12-14-70	SIZE B CODE IDENT NO. 00779 NUMBER 52431
		DSGN APPD.	SCALE NTS SHEET 1 OF 1
		OTHER APPD.	

TABLE II

PART NO	PART NO ON TAPE	WIRE INS. DIA
8-52431-2		.150 - .250
52431-1	52431-3	.150 - .250
52431	OBS. 52431-2	.150 - .230