

4

3

2

1

THIS DRAWING IS UNPUBLISHED. RELEASED FOR PUBLICATION
 © COPYRIGHT - BY TYCO ELECTRONICS CORPORATION. ALL RIGHTS RESERVED.

LOC	DIST	REVISIONS				
P	LTR	DESCRIPTION	DATE	DWN	APVD	
G	14	G2	REV PER ECR 10-000692	13JAN10	JR	TM

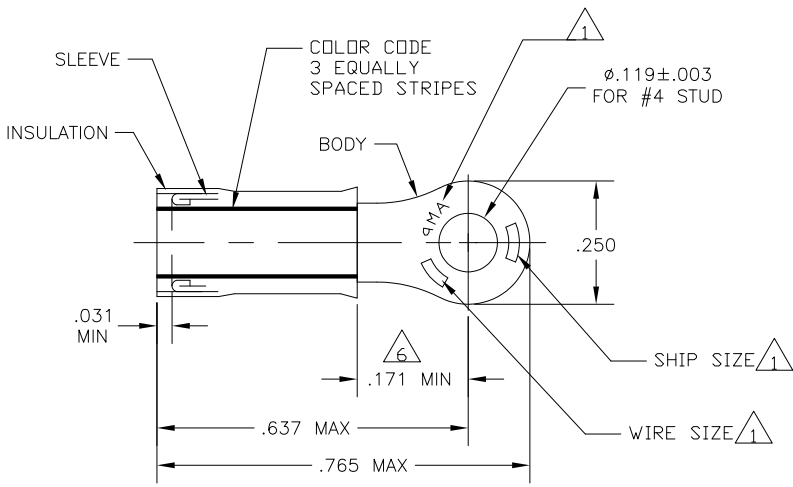

AMP WIRE RANGE	E13288 Listed	LR7189 Certified
16-14 AWG SOLID OR STRANDED	16-14 AWG SOLID OR STRANDED	16-14 AWG SOLID OR STRANDED

- ① STAMP "AMP ", SEE TABLE APPROX AS SHOWN
- ② WIRE INSULATION DIA: SEE TABLE
- ③ TONGUE MATERIAL THK: .031±.002
- ④ BODY & SLEEVE: CU PER ASTM B152
BODY & SLEEVE: TIN PLATE .000100 MIN
EXT THK PER ASTM B545
INSULATION: NYLON PER ASTM D4066,
COLOR-BLUE
- ⑤ APPLIES FROM EDGE OF METAL WIRE BARREL
TO CENTER OF STUD HOLE.
- ⑥ MEETS M7928/1-38, CLASS 1 & 2
- ⑦ MEETS M7928/1-47, CLASS 1 & 2

PART NO	PART NO. ON TAPE	WIRE SIZE	COLOR CODE	INSULATION DIA	WIRE	SHIP SIZE	STAMPING
52274-1	52274-3	14	GREEN	.078-.130	14	4	
52274	52274-2	16	BLUE	.063-.130	16	2 1/2	

OBSOLETE	2500	52274-1 ON TAPE, REELED	④	52274-3
OBSOLETE	2500	52274 ON TAPE, REELED	④	52274-2
	500	LOOSE PIECE	④	⑦ 52274-1
	500	LOOSE PIECE	④	⑥ 52274
QTY		PACKAGE TYPE	MATERIAL FINISH	PART NO

CUSTOMER SERVICE SYSTEMS

FOR ADDITIONAL PRODUCT INFORMATION OR COPIES OF DRAWINGS AND TECHNICAL DOCUMENTS: PRODUCT INFORMATION CENTER 1-800-522-6752

FOR APPLICATION TOOLING ASSISTANCE CENTER: TOOLING INFORMATION 1-800-722-1111

FOR ORDER ENTRY: 1-800-526-5142

MAX RECOMMENDED OPERATING TEMPERATURE: 170°C MAX

VOLTAGE RATING: 300 V MAX

CIRCULAR MIL AREA: 1.04-2.62mm² [2.050-5.180] STRANDED OR SOLID

THIS DRAWING IS A CONTROLLED DOCUMENT FOR AMP INCORPORATED. IT IS SUBJECT TO CHANGE AND THE CONTROLLING ENGINEERING ORGANIZATION SHOULD BE CONTACTED FOR THE LATEST REVISION.

THIS DRAWING IS A CONTROLLED DOCUMENT.

DIMENSIONS: INCHES

TOLERANCES UNLESS OTHERWISE SPECIFIED:

0 PLC	± -
1 PLC	± -
2 PLC	± -
3 PLC	± .008
4 PLC	± -
ANGLES	± -

MATERIAL: SEE TABLE

FINISH: SEE TABLE

DWN: JR RUTH 13JAN10
 CHK: T MICHELUTTI 13JAN10
 APVD: T MICHELUTTI 13JAN10

Tyco Electronics Tyco Electronics Corporation
 Harrisburg, Pa 17105-3608

NAME: TERMINAL, RING TONGUE, PIDG, INSULATION RESTRICTING, WIRE SIZE: 16-14 AWG

SIZE: A3 CAGE CODE: 00779 DRAWING NO: 52274

RESTRICTED TO: -

WEIGHT: -

CUSTOMER DRAWING SCALE: 5:1 SHEET: 1 OF 1 REV: G2

AMP 1470-19 REV 31MAR2000