

REV	DATE	DESCRIPTION	BY	APP'D
1				
2				
3				
4				

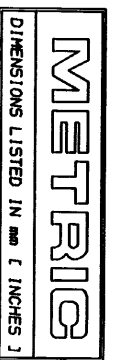

<b>AMP</b>	<b>WIRE RANGE</b>	<b>UL</b> E13288 Listed
	12-10 AWG STRANDED	12-10 AWG STRANDED
	● LR7189 Certified	MILITARY P/N AND CLASS
	NOT CERTIFIED	NOT APPLICABLE

△ STAMP AMP 12-10\* APPROX AS SHOWN

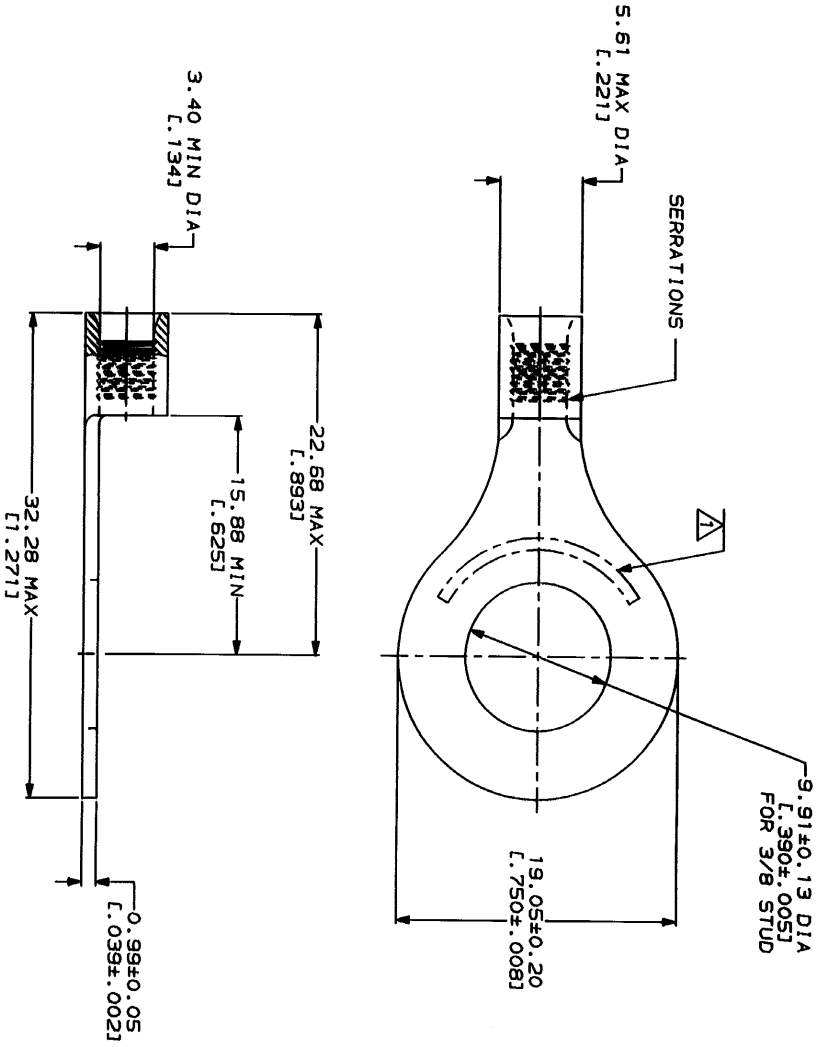

**AMP INCORPORATED  
CUSTOMER SERVICE SYSTEMS**

FOR ADDITIONAL PRODUCT INFORMATION OR COPIES OF DRAWINGS AND TECHNICAL DOCUMENTS  
1-800-522-6752

FOR APPLICATION TOOLING INFORMATION  
1-800-722-1111

FOR ORDER ENTRY  
1-800-526-5142

MAX RECOMMENDED OPERATING TEMPERATURE:  
170°C MAX

VOLTAGE RATING:  
NOT APPLICABLE

WIRE CROSS SECTIONAL AREA RANGE:  
2.62-6.64mm<sup>2</sup> [5.180-13.100] CIR MILS STRANDED

THIS DRAWING IS A TYPE III DRAWING OF AN AMP PRODUCT. IT IS THE PROPERTY OF AMP AND IS LOANED TO YOU FOR YOUR INFORMATION AND USE ONLY. IT IS NOT TO BE REPRODUCED OR COPIED FOR ANY OTHER PURPOSE.

DO NOT SCALE PRINT. UNLESS SPECIFIED OTHERWISE, DIMENSIONS ARE IN MILLIMETERS. TOLERANCES: ON 1. P/LC DEC ±. ANGLES ±.

FINISH: TIN PLATE  
0.00254 [L.000100] MIN THK PER MIL-T-10727

DR: 2-9-93 TA BRINKMAN  
CHK: 2-9-93 DA PATTERSON  
APPD: 2-9-93 DE MILLER  
APPD: 2-9-93 JL WICKLEY

APPLICATION SPEC

**AMP**  
AMP Incorporated  
Hornbush, PA 17105-3608

TERMINAL, RING TONGUE, BUDGET

SIZE: CASE CODE 00779  
SCALE: 4:1  
DRAWING NO: 34833  
SHEET: 1 OF 1

34833 PART NO

34833