

4

3

2

1

THIS DRAWING IS UNPUBLISHED. RELEASED FOR PUBLICATION
 © COPYRIGHT - BY TYCO ELECTRONICS CORPORATION. ALL RIGHTS RESERVED.

LOC	DIST	REVISIONS					
		P	LTR	DESCRIPTION	DATE	DWN	APVD
G	14	G		REV PER 0G3A-0642-04	16AUG04	JR	TM

AMP WIRE RANGE	Listed FILE E13288	LR7189 Certified
22-16 AWG SOLID OR STRANDED	22-16 AWG SOLID OR STRANDED	22-16 AWG SOLID OR STRANDED

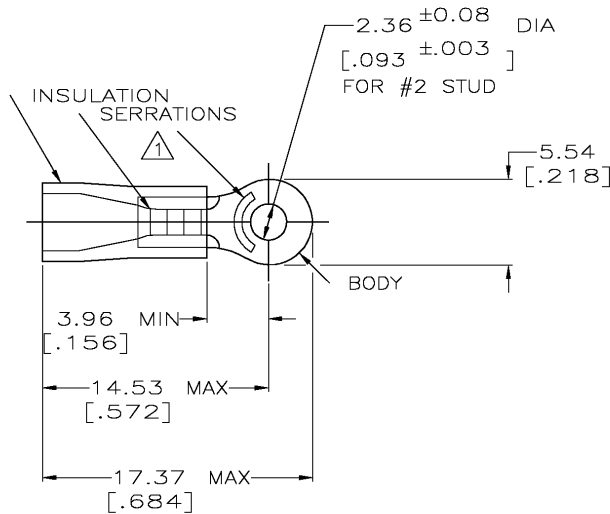

- 1 STAMP AMP 22-18* 1-2 APPROX AS SHOWN
22-16 TERMINALS ARE STAMPED 22-18 IN
ACCORDANCE WITH MILITARY SPEC MIL-T-7928
COMMERCIAL WIRE RANGE IS 22-16
- 2 WIRE INSULATION DIA: 2.67-3.56 [0.105-.140]
- 3 TONGUE MATERIAL THK: 0.79 ±0.05 [0.031 ±0.002]
- 4 MATERIAL: BODY - CU PER ASTM B152
SLEEVE - PVC, COLOR - RED

100	LOOSE PC,BOX	8-34140-1
5000	ON TAPE, REEL	2-34140-1
1000	LOOSE PIECE	34140
QTY	PACKAGE TYPE	PART NO

AMP INCORPORATED CUSTOMER SERVICE SYSTEMS		MAX RECOMMENDED OPERATING TEMPERATURE: 105°C [221°F]	THIS DRAWING IS A CONTROLLED DOCUMENT.		DWN DK SCHRUM 08/06/92	Tyco Electronics Corporation Harrisburg, Pa 17105-3608	
FOR ADDITIONAL PRODUCT INFORMATION OR COPIES OF DRAWINGS AND TECHNICAL DOCUMENTS	PRODUCT INFORMATION CENTER 1-800-522-6752	VOLTAGE RATING: 600V MAX (1000V FIXTURE OR SIGN)	DIMENSIONS: MM [INCHES]	TOLERANCES UNLESS OTHERWISE SPECIFIED: 0 PLC ± - 1 PLC ± - 2 PLC ± 0.20[008] 3 PLC ± - 4 PLC ± - ANGLES ± -	CHK RE HERSEY 11/10/92		NAME M BARNABA 11/10/92
FOR APPLICATION	TOOLING ASSISTANCE CENTER 1-800-722-1111	CIRCULAR MIL AREA: 0.26-1.85mm² [509-3260] SOLID OR STRANDED		MATERIAL TIN PER ASTM B545	FINISH TIN PER ASTM B545	PRODUCT SPEC UL 486A	TERMINAL, RING TONGUE, PLASTI-GRIP, WIRE SIZE, 22-16 AWG
TOOLING INFORMATION	1-800-722-1111	THIS DRAWING IS A CONTROLLED DOCUMENT FOR AMP INCORPORATED. IT IS SUBJECT TO CHANGE AND THE CONTROLLING ENGINEERING ORGANIZATION SHOULD BE CONTACTED FOR THE LATEST REVISION.		RESTRICTED TO	SIZE A3	CAGE CODE 00779	DRAWING NO C-34140
FOR ORDER ENTRY	1-800-526-5142			CUSTOMER DRAWING	SCALE 4:1	SHEET 1 OF 1	REV G

AMP 1470-19 REV 31MAR2000