



# 5.0Gbps PCI Express Passive Switches

MAX4888A/MAX4889A

## General Description

The MAX4888A/MAX4889A high-speed passive switches route PCI Express® (PCIe) data between two possible destinations. The MAX4888A is a quad single-pole/double-throw (4 x SPDT) switch ideally suited for switching two half lanes of PCIe data between two destinations. The MAX4889A is an octal single-pole/double-throw (8 x SPDT) switch ideal for switching four half lanes of PCIe data between four destinations. The MAX4888A/MAX4889A feature a single digital control input (SEL) to switch signal paths.

The MAX4888A/MAX4889A are fully specified to operate from a single +3.0V to +3.6V power supply††. The MAX4888A is available in a 3.5mm x 5.5mm, 28-pin TQFN package. The MAX4889A is available in a 3.5mm x 9.0mm, 42-pin TQFN package. Both devices operate over the -40°C to +85°C temperature range.

## Features

- ◆ Single +3.0V to +3.6V Power-Supply Voltage
- ◆ Low Same-Pair Skew of 7ps
- ◆ Low 120µA (Max) Quiescent Current
- ◆ Supports PCIe Gen I and Gen II Data Rates
- ◆ Flow-Through Pin Configuration for Ease of Layout
- ◆ Industry-Compatible Pinout
- ◆ Lead-Free Packaging

## Applications

Desktop Computers  
Servers/Storage Area Networks  
Laptops

## Ordering Information/Selector Guide

PART	TEMP RANGE	PIN-PACKAGE	CONFIGURATION
MAX4888AETI+	-40°C to +85°C	28 TQFN-EP*	Two Half Lanes
MAX4889AETO+	-40°C to +85°C	42 TQFN-EP*	Four Half Lanes

+Denotes lead(Pb)-free/RoHS-compliant package.

\*EP = Exposed paddle.

††Contact factory if operating at +2.5V or +1.8V.

PCI Express is a registered trademark of PCI-SIG Corp.

Typical Application Circuit appears at end of data sheet.

## Pin Configurations

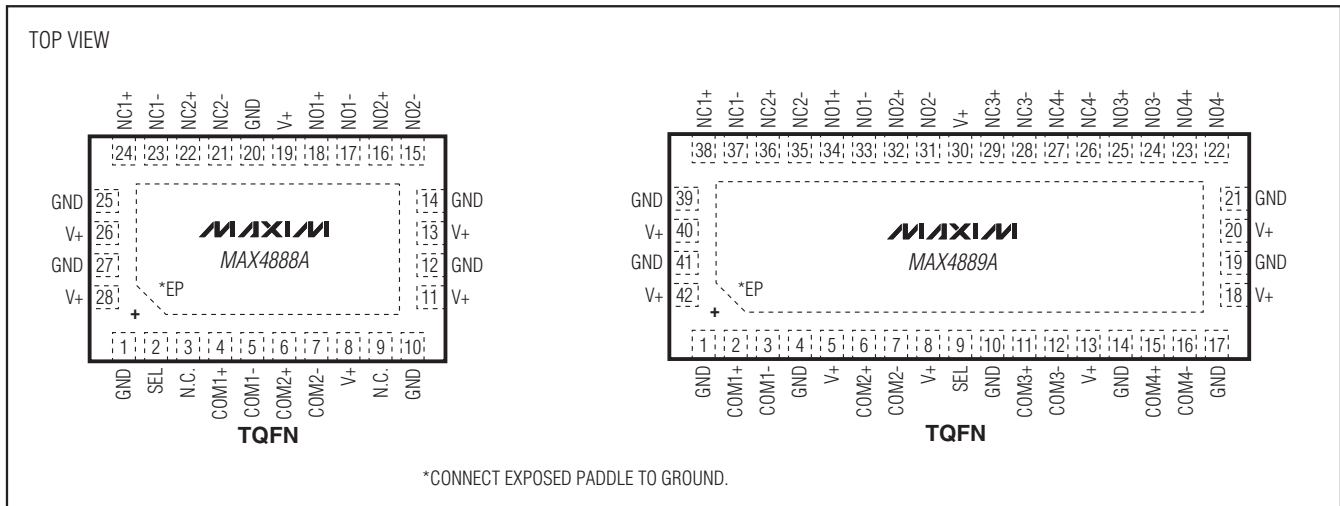

For pricing, delivery, and ordering information, please contact Maxim Direct at 1-888-629-4642, or visit Maxim's website at [www.maxim-ic.com](http://www.maxim-ic.com).

# 5.0Gbps PCI Express Passive Switches

## ABSOLUTE MAXIMUM RATINGS

(All voltages referenced to GND, unless otherwise noted.)

V+	.....-0.3V to +4V
SEL, COM_, NO_, NC_ (Note 1)	.....-0.3V to (V+ + 0.3V)
I COM_ - NO_ I, I COM_ - NC_ I (Note 1)	.....0 to +2V
Continuous Current (COM_ to NO_/NC_)	.....±70mA
Peak Current (COM_ to NO_/NC_)	.....±70mA
(pulsed at 1ms, 10% duty cycle)	.....±70mA
Continuous Current (SEL)	.....±30mA
Peak Current (SEL)	.....±30mA
(pulsed at 1ms, 10% duty cycle)	.....±150mA

Continuous Power Dissipation (T<sub>A</sub> = +70°C)

28-Pin TQFN (derate 20.8mW/°C above +70°C)	.....1666.7mW
42-Pin TQFN (derate 35.7mW/°C above +70°C)	.....2857.1mW
Operating Temperature Range	.....-40°C to +85°C
Storage Temperature Range	.....-65°C to +150°C
Lead Temperature (soldering, 10s)	.....+300°C
Junction Temperature	.....+150°C

**Note 1:** Signals on SEL, NO\_, NC\_ or COM\_ exceeding V+ or GND are clamped by internal diodes. Limit forward-diode current to maximum current rating.

Stresses beyond those listed under "Absolute Maximum Ratings" may cause permanent damage to the device. These are stress ratings only, and functional operation of the device at these or any other conditions beyond those indicated in the operational sections of the specifications is not implied. Exposure to absolute maximum rating conditions for extended periods may affect device reliability.

## ELECTRICAL CHARACTERISTICS

(V+ = +3.0V to +3.6V, T<sub>A</sub> = -40°C to +85°C, unless otherwise noted. Typical values are at V+ = +3.3V, T<sub>A</sub> = +25°C.) (Note 2)

PARAMETER	SYMBOL	CONDITIONS	MIN	TYP	MAX	UNITS
<b>ANALOG SWITCH</b>						
Analog-Signal Range	V <sub>COM_</sub> , V <sub>NO_</sub> , V <sub>NC_</sub>				(V+ - 1.2)	V
Voltage Between COM and NO/NC	I V <sub>COM_</sub> - V <sub>NO_</sub> I, I V <sub>COM_</sub> - V <sub>NC_</sub> I		0		1.8	V
On-Resistance	R <sub>ON</sub>	V+ = +3.0V, I <sub>COM_</sub> = 15mA, V <sub>NO_</sub> or V <sub>NC_</sub> = 0V, +1.8V		7		Ω
On-Resistance Match Between Pairs of Same Channel	R <sub>ON</sub>	V+ = +3.0V, I <sub>COM_</sub> = 15mA, V <sub>NO_</sub> or V <sub>NC_</sub> = 0V (Notes 3, 4)		0.1	1	Ω
On-Resistance Match Between Channels	R <sub>ON</sub>	V+ = +3.0V, I <sub>COM_</sub> = 15mA, V <sub>NO_</sub> or V <sub>NC_</sub> = 0V (Notes 3, 4)		0.6	2	Ω
On-Resistance Flatness	R <sub>FLAT(ON)</sub>	V+ = +3.0V, I <sub>COM_</sub> = 15mA V <sub>NO_</sub> or V <sub>NC_</sub> = 0V, +1.8V (Notes 4, 5)		0.06	2	Ω
NO_ or NC_ Off-Leakage Current	I <sub>NO_(OFF)</sub> I <sub>NC_(OFF)</sub>	V+ = +3.6V, V <sub>COM_</sub> = 0V, +1.8V, V <sub>NO_</sub> or V <sub>NC_</sub> = +1.8V, 0V	-1		+1	μA
COM_ On-Leakage Current	I <sub>COM_(ON)</sub>	V+ = +3.6V, V <sub>COM_</sub> = 0V, +1.8V, V <sub>NO_</sub> or V <sub>NC_</sub> = V <sub>COM_</sub> or unconnected	-1		+1	μA

# 5.0Gbps PCI Express Passive Switches

MAX4888A/MAX4889A

## ELECTRICAL CHARACTERISTICS (continued)

(V+ = +3.0V to +3.6V, T<sub>A</sub> = -40°C to +85°C, unless otherwise noted. Typical values are at V+ = +3.3V, T<sub>A</sub> = +25°C.) (Note 2)

PARAMETER	SYMBOL	CONDITIONS		MIN	TYP	MAX	UNITS
<b>DYNAMIC</b>							
Turn-On Time	t <sub>ON</sub>	V <sub>NO_</sub> or V <sub>NC_</sub> = +1.0V, R <sub>L</sub> = 50Ω, Figure 1			90	250	ns
Turn-Off Time	t <sub>OFF</sub>	V <sub>NO_</sub> or V <sub>NC_</sub> = +1.0V, R <sub>L</sub> = 50Ω, Figure 1			10	50	ns
Propagation Delay	t <sub>PD</sub>	R <sub>S</sub> = R <sub>L</sub> = 50Ω, unbalanced, Figure 2			50		ps
Output Skew Between Pairs	t <sub>SK1</sub>	R <sub>S</sub> = R <sub>L</sub> = 50Ω, unbalanced; skew between any two pairs, Figure 2			50		ps
Output Skew Between Same Pair	t <sub>SK2</sub>	R <sub>S</sub> = R <sub>L</sub> = 50Ω, unbalanced; skew between two lines on same pair, Figure 2			10		ps
On-Loss	G <sub>LOS</sub>	R <sub>S</sub> = R <sub>L</sub> = 50Ω, unbalanced, Figure 3	1MHz < f < 100MHz		-0.5		dB
			500MHz < f < 1.25GHz		-1.4		
Crosstalk	V <sub>CT1</sub>	Crosstalk between any two pairs, R <sub>S</sub> = R <sub>L</sub> = 50Ω, unbalanced, Figure 3	f = 50MHz		-53		dB
			f = 1.25GHz		-32		
Signaling Data Rate	BR	R <sub>S</sub> = R <sub>L</sub> = 50Ω			5.0		Gbps
Off-Isolation	V <sub>ISO</sub>	Signal = 0dBm, R <sub>S</sub> = R <sub>L</sub> = 50Ω, Figure 3	f = 10MHz		-56		dB
			f = 1.25GHz		-26		
NO_/NC_ Off-Capacitance	C <sub>NO_/NC_(OFF)</sub>	Figure 4			1		pF
COM_ On-Capacitance	C <sub>COM_(ON)</sub>	Figure 4			2		pF
<b>LOGIC INPUT</b>							
Input-Logic Low	V <sub>IL</sub>					0.5	V
Input-Logic High	V <sub>IH</sub>			1.4			V
Input-Logic Hysteresis	V <sub>HYST</sub>				100		mV
Input Leakage Current	I <sub>IN</sub>	V <sub>SEL</sub> = 0V or V+		-1		+1	μA
<b>POWER SUPPLY</b>							
Power-Supply Range	V+			1.65		3.60	V
V+ Supply Current	I+	V <sub>SEL</sub> = 0V or V+	MAX4888A			60	μA
			MAX4889A			120	
Input Leakage Current	I <sub>IN</sub>	V <sub>SEL</sub> = 0V or V+		-1		+1	μA
<b>ESD PROTECTION</b>							
COM_+, COM_-		Human Body Model			±6		kV

**Note 2:** All units are 100% production tested at T<sub>A</sub> = +85°C. Limits over the operating temperature range are guaranteed by design and characterization and are not production tested.

**Note 3:** ΔR<sub>ON</sub> = R<sub>ON(MAX)</sub> - R<sub>ON(MIN)</sub>.

**Note 4:** Guaranteed by design. Not production tested.

**Note 5:** Flatness is defined as the difference between the maximum and minimum value of on-resistance as measured over the specified analog signal range.

# 5.0Gbps PCI Express Passive Switches

## Typical Operating Characteristics

( $T_A = +25^\circ\text{C}$ , unless otherwise noted.)

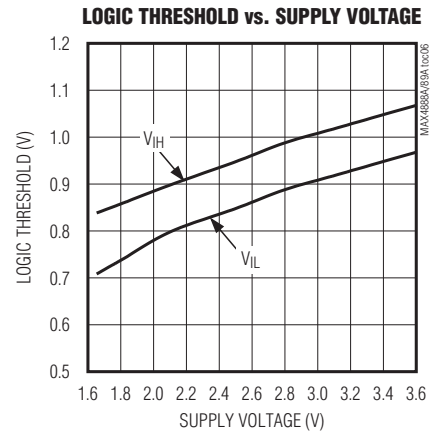
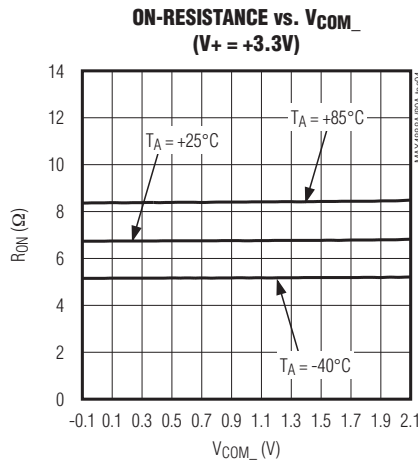
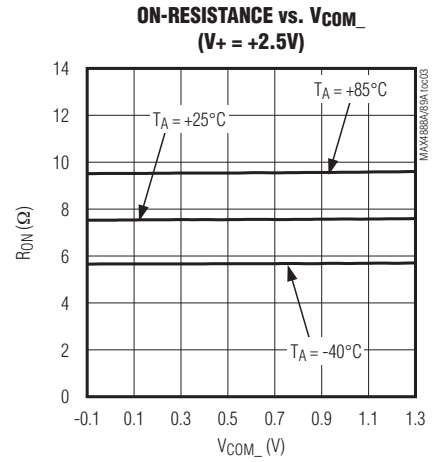
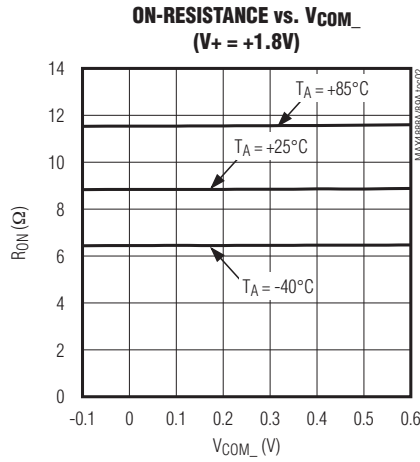
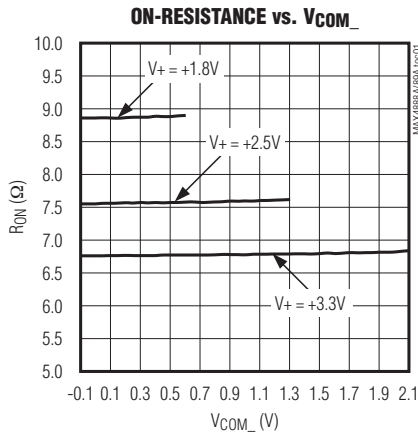

# 5.0Gbps PCI Express Passive Switches

**MAX4888A/MAX4889A**

## Typical Operating Characteristics (continued)

( $T_A = +25^\circ\text{C}$ , unless otherwise noted.)

**EYE DIAGRAM**  
( $V_+ = +1.8\text{V}$ ,  $f = 1.25\text{GHz}$ ,  
600mV<sub>p-p</sub> PRBS SIGNAL,  $R_S = R_L = 50\Omega$ )†

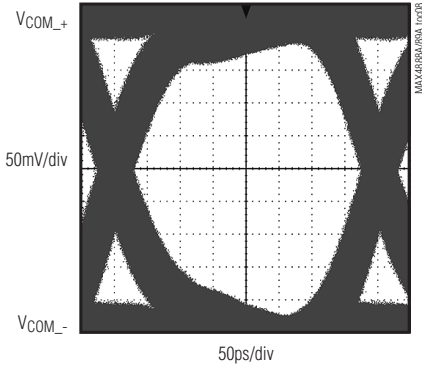

\*PRBS = PSEUDORANDOM BIT SEQUENCE  
† = GEN 1, 2.5Gbps; U1 = 400ps

**EYE DIAGRAM**  
( $V_+ = +2.5\text{V}$ ,  $f = 1.25\text{GHz}$ ,  
600mV<sub>p-p</sub> PRBS SIGNAL,  $R_S = R_L = 50\Omega$ )†

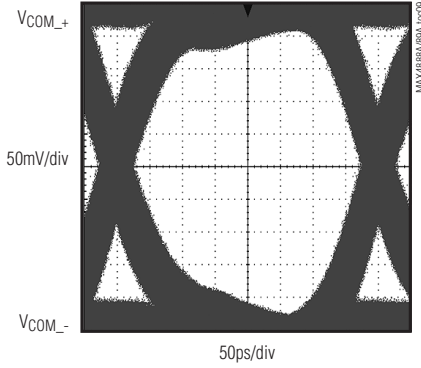

\*PRBS = PSEUDORANDOM BIT SEQUENCE  
† = GEN 1, 2.5Gbps; U1 = 400ps

**EYE DIAGRAM**  
( $V_+ = +3.3\text{V}$ ,  $f = 1.25\text{GHz}$ ,  
600mV<sub>p-p</sub> PRBS SIGNAL,  $R_S = R_L = 50\Omega$ )†



\*PRBS = PSEUDORANDOM BIT SEQUENCE  
† = GEN 1, 2.5Gbps; U1 = 400ps

**EYE DIAGRAM**  
( $V_+ = +1.8\text{V}$ ,  $f = 2.5\text{GHz}$ ,  
600mV<sub>p-p</sub> PRBS SIGNAL,  $R_S = R_L = 50\Omega$ )††

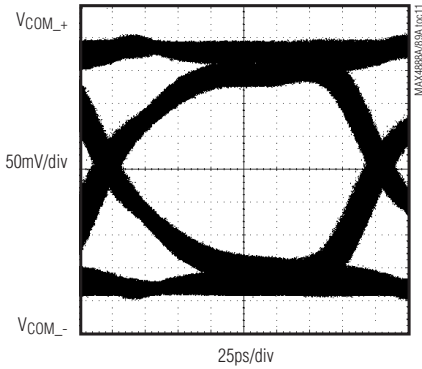

\*PRBS = PSEUDORANDOM BIT SEQUENCE  
†† = GEN 11, 5.0Gbps; U1 = 200ps

**EYE DIAGRAM**  
( $V_+ = +2.5\text{V}$ ,  $f = 2.5\text{GHz}$ ,  
600mV<sub>p-p</sub> PRBS SIGNAL,  $R_S = R_L = 50\Omega$ )††

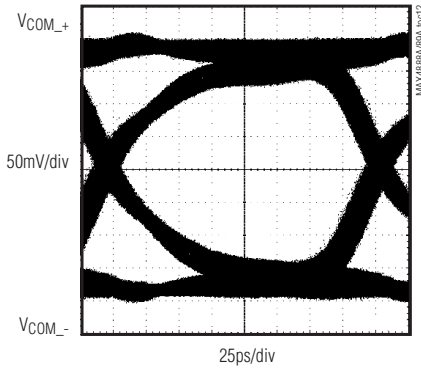

\*PRBS = PSEUDORANDOM BIT SEQUENCE  
†† = GEN 11, 5.0Gbps; U1 = 200ps

**EYE DIAGRAM**  
( $V_+ = +3.3\text{V}$ ,  $f = 2.5\text{GHz}$ ,  
600mV<sub>p-p</sub> PRBS SIGNAL,  $R_S = R_L = 50\Omega$ )††



\*PRBS = PSEUDORANDOM BIT SEQUENCE  
†† = GEN 11, 5.0Gbps; U1 = 200ps

# 5.0Gbps PCI Express Passive Switches

## Pin Description

PIN		NAME	FUNCTION
MAX4888A	MAX4889A		
1, 10, 12, 14, 20, 25, 27	1, 4, 10, 14, 17, 19, 21, 39, 41	GND	Ground
2	9	SEL	Digital Control Input
3, 9	—	N.C.	No Connection. Not internally connected.
4	2	COM1+	Analog Switch 1. Common Positive Terminal.
5	3	COM1-	Analog Switch 1. Common Negative Terminal.
6	6	COM2+	Analog Switch 2. Common Positive Terminal.
7	7	COM2-	Analog Switch 2. Common Negative Terminal.
8, 11, 13, 19, 26, 28	5, 8, 13, 18, 20, 30, 40, 42	V+	Positive-Supply Voltage Input. Connect V+ to a +3.0V to +3.6V supply voltage. Bypass V+ to GND with a 0.1µF capacitor placed as close to the device as possible (See the <i>Board Layout</i> section).
15	31	NO2-	Analog Switch 2. Normally Open Negative Terminal.
16	32	NO2+	Analog Switch 2. Normally Open Positive Terminal.
17	33	NO1-	Analog Switch 1. Normally Open Negative Terminal.
18	34	NO1+	Analog Switch 1. Normally Open Positive Terminal.
21	35	NC2-	Analog Switch 2. Normally Closed Negative Terminal.
22	36	NC2+	Analog Switch 2. Normally Closed Positive Terminal.
23	37	NC1-	Analog Switch 1. Normally Closed Negative Terminal.
24	38	NC1+	Analog Switch 1. Normally Closed Positive Terminal.
—	11	COM3+	Analog Switch 3. Common Positive Terminal.
—	12	COM3-	Analog Switch 3. Common Negative Terminal.
—	15	COM4+	Analog Switch 4. Common Positive Terminal.
—	16	COM4-	Analog Switch 4. Common Negative Terminal.
—	22	NO4-	Analog Switch 4. Normally Open Negative Terminal.
—	23	NO4+	Analog Switch 4. Normally Open Positive Terminal.
—	24	NO3-	Analog Switch 3. Normally Open Negative Terminal.
—	25	NO3+	Analog Switch 3. Normally Open Positive Terminal.
—	26	NC4-	Analog Switch 4. Normally Closed Negative Terminal.
—	27	NC4+	Analog Switch 4. Normally Closed Positive Terminal.
—	28	NC3-	Analog Switch 3. Normally Closed Negative Terminal.
—	29	NC3+	Analog Switch 3. Normally Closed Positive Terminal.
—	—	EP	Exposed Paddle. Connect EP to GND.

# 5.0Gbps PCI Express Passive Switches

## Test Circuits/Timing Diagrams

**MAX4888A/MAX4889A**



Figure 1. Switching Time

# 5.0Gbps PCI Express Passive Switches

## Test Circuits/Timing Diagrams (continued)

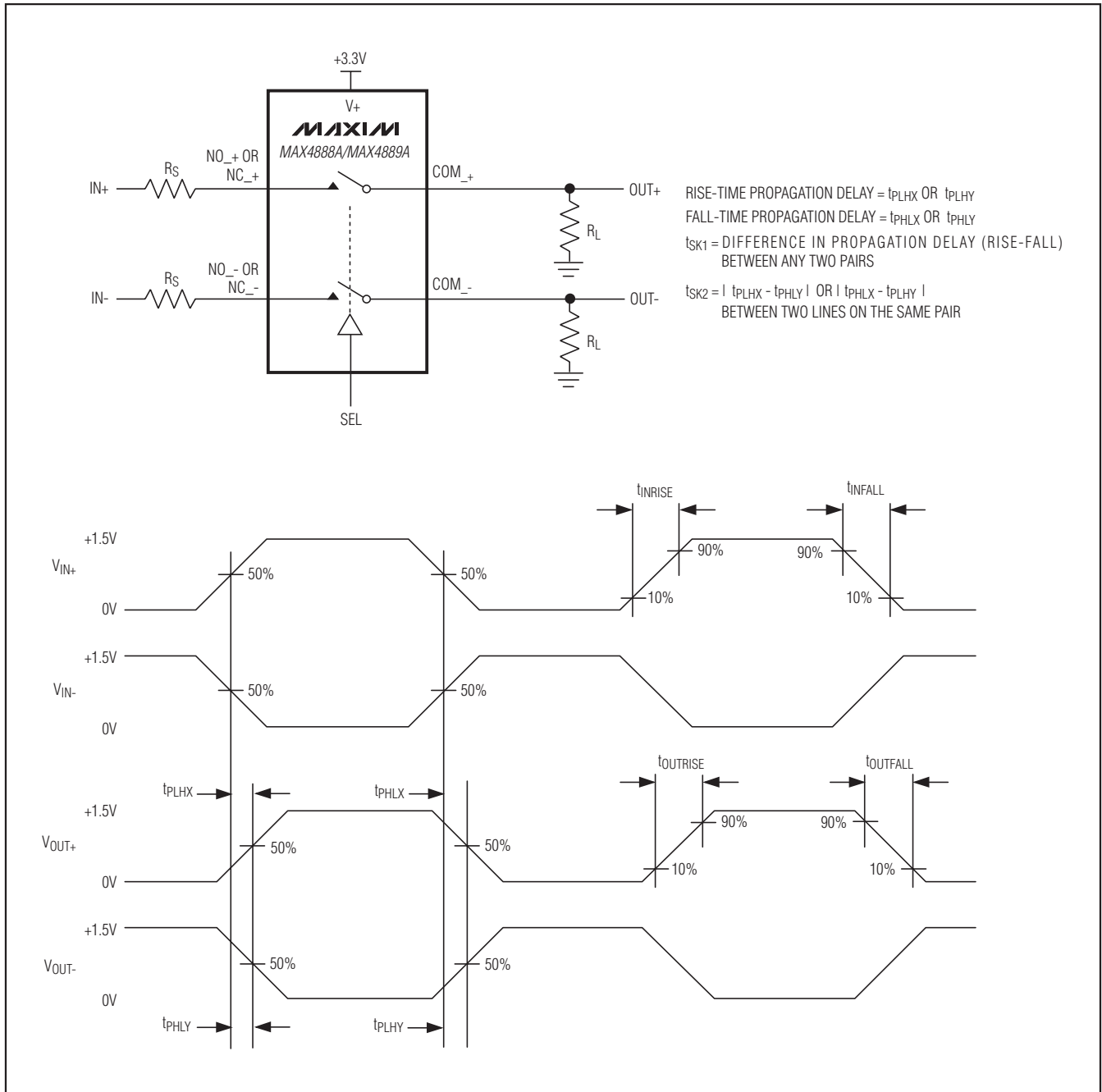

Figure 2. Propagation Delay and Output Skew



# 5.0Gbps PCI Express Passive Switches

MAX4888A/MAX4889A

## Test Circuits/Timing Diagrams (continued)

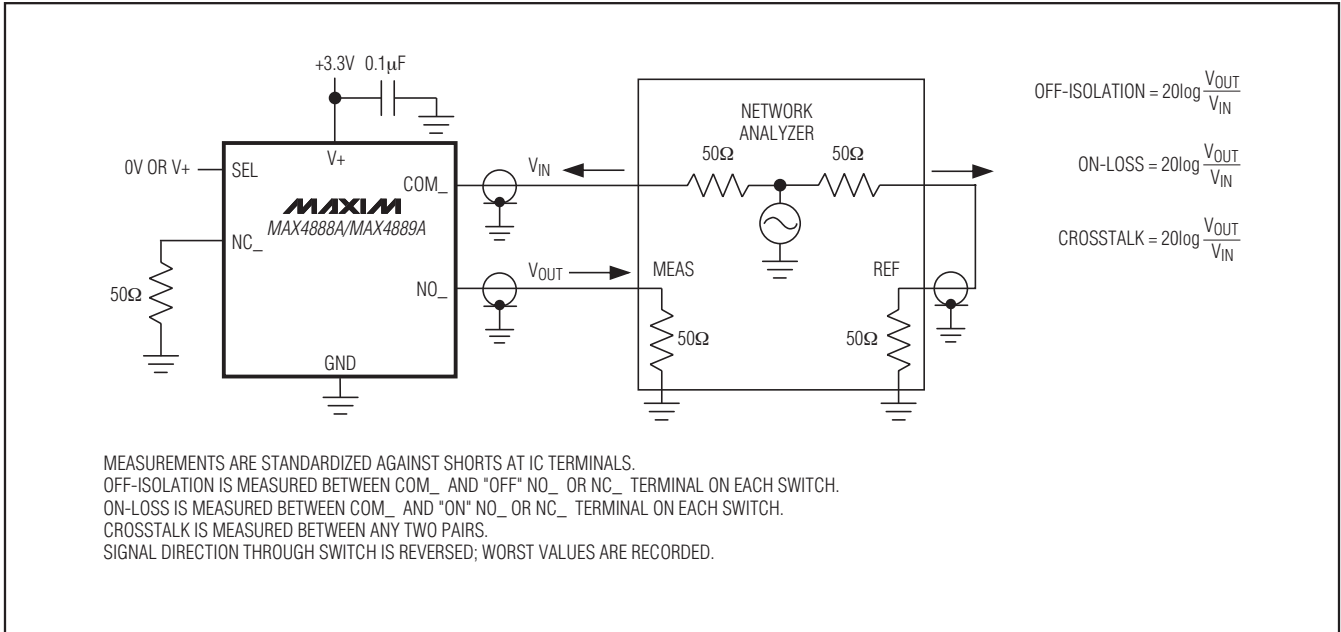

Figure 3. On-Loss, Off-Isolation, and Crosstalk

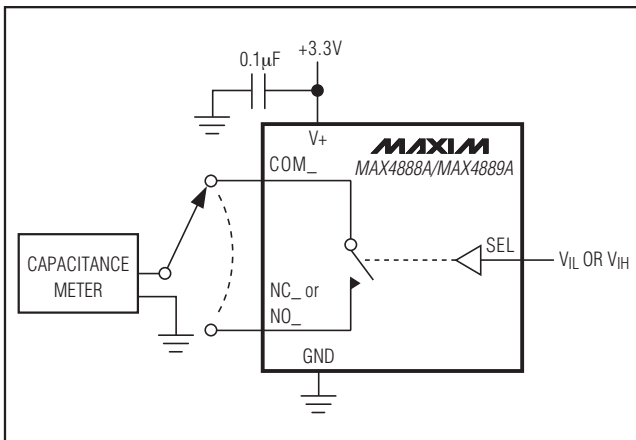

Figure 4. Channel Off-/On-Capacitance

## Detailed Description

The MAX4888A/MAX4889A high-speed passive switches route PCIe data between two possible destinations. The MAX4888A/MAX4889A are ideal for routing PCIe signals to change the system configuration. For example, in a graphics application, the MAX4888A/MAX4889A create

two sets of eight lanes from a single 16-lane bus. The MAX4888A/MAX4889A feature a single digital control input (SEL) to switch signal paths.

The MAX4888A/MAX4889A are fully specified to operate from a single +3.0V to +3.6V power supply††.

### Digital Control Input (SEL)

The MAX4888A/MAX4889A provide a single digital control input (SEL) to select the signal path between the COM\_ and NO\_/NC\_ channels. The truth tables for the MAX4888A/MAX4889A are depicted in the *Functional Diagrams/Truth Table* section. Drive SEL rail-to-rail to minimize power consumption.

### Analog Signal Levels

The MAX4888A/MAX4889A accept standard PCIe signals to a maximum of  $V_+ - 1.2V$ . Signals on the COM\_+ channels are routed to either the NO\_+ or NC\_+ channels, and signals on the COM\_- channels are routed to either the NO\_- or NC\_- channels. The MAX4888A/MAX4889A are bidirectional switches, allowing COM\_, NO\_, and NC\_ to be used as either inputs or outputs.

††Contact factory if operating at +2.5V or +1.8V.

# 5.0Gbps PCI Express Passive Switches

## Functional Diagrams/Truth Table



SEL	COM_TO NC_	COM_TO NO_
0	ON	OFF
1	OFF	ON



# 5.0Gbps PCI Express Passive Switches

## Applications Information

### PCIe Switching

The MAX4888A/MAX4889A primary applications are aimed at reallocating PCIe lanes (see Figure 5). For example, in graphics applications, several manufacturers have found that it is possible to improve performance by a factor of nearly two by splitting a single 16-lane PCIe bus into two 8-lane buses. Two of the more prominent examples are SLI™ (Scaled Link Interface) and CrossFire™. The MAX4889A permits a computer motherboard to operate properly with a single 16-lane graphics card, and can later be updated to dual cards. The same motherboard can be used with dual cards where the user sets a jumper or a bit through software to switch between single- or dual-card operation. Common mode below 1V operation requirement.

### Board Layout

High-speed switches require proper layout and design procedures for optimum performance. Keep design-controlled impedance PCB traces as short as possible or follow impedance layouts per the PCIe specification. Ensure that power-supply bypass capacitors are placed as close to the device as possible. Multiple bypass capacitors are recommended. Connect all grounds and the exposed pad to large ground planes. Common mode below 1V operation requirement.



Figure 5. The MAX4888A/MAX4889A Used as a Single-Lane Switch

CrossFire is a trademark of ATI Technologies, Inc.

SLI is a trademark of NVIDIA Corporation.

### ESD Protection

As with all Maxim devices, ESD-protection structures are incorporated on all pins to protect against electrostatic discharges encountered during handling and assembly. The COM\_+ and COM\_- lines have extra protection against static electricity. Maxim's engineers have developed state-of-the-art structures to protect these pins against ESD of ±6kV without damage. The ESD structures withstand ±6kV of ESD in all states: normal operation, state output mode, and powered down.

### Human Body Model

The MAX4889A COM\_+ and COM\_- pins are characterized for ±6kV ESD protection using the Human Body Model (MIL-STD-883, Method 3015). Figure 6 shows the Human Body Model and Figure 7 shows the current waveform it generates when discharged into low impedance. This model consists of a 100pF capacitor charged to the ESD voltage of interest, which is then discharged into the device through a resistor.

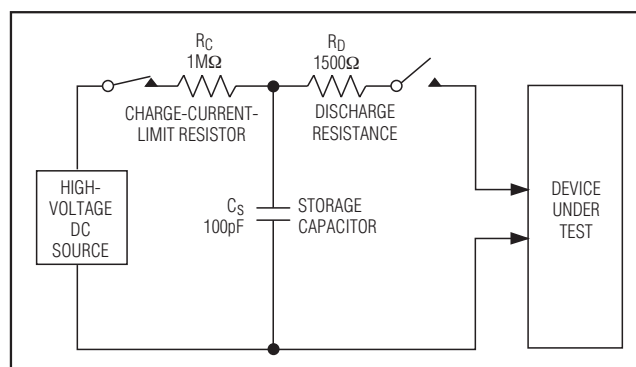

Figure 6. Human Body ESD Test Model

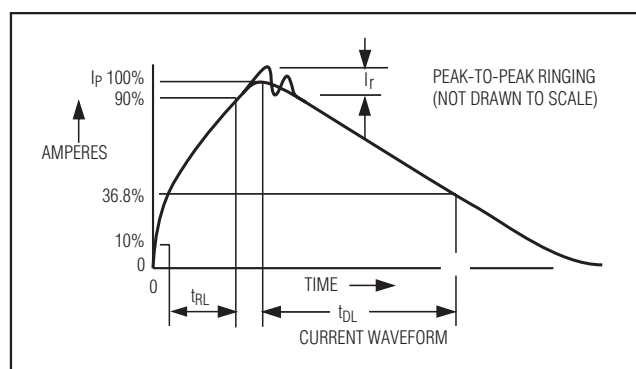

Figure 7. Human Body Model Current Waveform

## Chip Information

PROCESS: CMOS

# 5.0Gbps PCI Express Passive Switches

## Typical Application Circuit



# 5.0Gbps PCI Express Passive Switches

## Package Information

For the latest package outline information and land patterns, go to [www.maxim-ic.com/packages](http://www.maxim-ic.com/packages).

PACKAGE TYPE	PACKAGE CODE	DOCUMENT NO.
28 TQFN-EP	T283555-1	<a href="#">21-0184</a>
42 TQFN-EP	T423590M-1	<a href="#">21-0181</a>

**MAX4888A/MAX4889A**

# 5.0Gbps PCI Express Passive Switches

## **Revision History**

<b>REVISION NUMBER</b>	<b>REVISION DATE</b>	<b>DESCRIPTION</b>	<b>PAGES CHANGED</b>
0	4/07	Initial release	—
2	5/09	Updated voltage range, style edits.	1, 2, 3, 5–9, 13, 14

Maxim cannot assume responsibility for use of any circuitry other than circuitry entirely embodied in a Maxim product. No circuit patent licenses are implied. Maxim reserves the right to change the circuitry and specifications without notice at any time.

14 **Maxim Integrated Products, 120 San Gabriel Drive, Sunnyvale, CA 94086 408-737-7600**

© 2009 Maxim Integrated Products

Maxim is a registered trademark of Maxim Integrated Products. Inc.