



Precision, Quad, SPST Analog Switches

MAX391/MAX392/MAX393

General Description

The MAX391/MAX392/MAX393 are precision, quad, single-pole/single-throw (SPST) analog switches designed to operate at +3V, +5V, or ±5V. The MAX391 has four normally closed (NC) switches, and the MAX392 has four normally open (NO) switches. The MAX393 has two NO and two NC switches. All three devices offer low leakage (100pA max) and fast switching speeds ($t_{ON} \leq 130ns$, $t_{OFF} \leq 75ns$). Power consumption is just 1μW—ideal for battery-operated equipment. All devices operate from a single +3V to +15V supply or from dual ±3.0V to ±8V supplies.

With ±5V supplies, the MAX391/MAX392/MAX393 offer guaranteed 2Ω max channel-to-channel matching, 30Ω max on-resistance (R_{ON}), and 4Ω max R_{ON} flatness over the specified range.

These switches are also fully specified for single +5V operation, with 2Ω max R_{ON} match, 60Ω max R_{ON} , and 6Ω max flatness.

These low-voltage switches also offer 5pC max charge injection, and ESD protection is greater than 2000V, per method 3015.7.

Applications

Battery-Operated Systems	Sample-and-Hold Circuits
Heads-Up Displays	Guidance and Control Systems
Audio and Video Switching	Military Radios
Test Equipment	Communications Systems
±5V DACs and ADCs	PBX, PABX

Features

- ◆ Low On-Resistance, 20Ω Typical
- ◆ Guaranteed On-Resistance Match Between Channels, < 2Ω
- ◆ Guaranteed On-Resistance Flatness Over Signal Range, 4Ω Max
- ◆ Guaranteed Charge Injection, < 5pC
- ◆ Improved Leakage Over Temperature, < 2.5nA at +85°C
- ◆ Electrostatic Discharge > 2000V per Method 3015.7
- ◆ Single-Supply Operation (+3V to +15V)
Bipolar-Supply Operation (±3V to ±8V)
- ◆ Low Power Consumption, < 1μW
- ◆ TTL/CMOS-Logic Compatible

Ordering Information

PART	TEMP RANGE	PIN-PACKAGE	PKG CODE
MAX391CPE	0°C to +70°C	16 Plastic DIP	P16-1
MAX391CSE	0°C to +70°C	16 Narrow SO	S16-2
MAX391CUE	0°C to +70°C	16 TSSOP	U16-2
MAX391CGE	0°C to +70°C	16 QFN-EP†	G1644-1
MAX391C/D	0°C to +70°C	Dice*	—
MAX391EPE	-40°C to +85°C	16 Plastic DIP	P16-1

Ordering Information continued on last page.

*Contact factory for dice specifications.

†EP = Exposed pad.

Pin Configurations/Functional Diagrams/Truth Tables

TOP VIEW

DIP/SO
MAX391

LOGIC	SWITCH
0	ON
1	OFF

N.C. = NO CONNECT

DIP/SO
MAX392

LOGIC	SWITCH
0	OFF
1	ON

SWITCHES SHOWN FOR LOGIC "0" INPUT

DIP/SO
MAX393

LOGIC	SWITCHES 1, 4	SWITCHES 2, 3
0	OFF	ON
1	ON	OFF



For pricing, delivery, and ordering information, please contact Maxim Direct at 1-888-629-4642, or visit Maxim's website at www.maxim-ic.com.

Precision, Quad, SPST Analog Switches

ABSOLUTE MAXIMUM RATINGS

Voltage Referenced to V-		Narrow SO (derate 8.70mW/°C above +70°C)696mW
V+	-0.3V to +17V	TSSOP (derate 6.7mW/°C above +70°C)457mW
GND.....	-0.3V to +17V	CERDIP (derate 10.00mW/°C above +70°C)800mW
GND.....	-0.3V to (V+ + 0.3V)	QFN (derate 18.5mW/°C above +70°C)1481mW
VIN_, VCOM_, VNC_, VNO_ (Note 1)	V- to V+	Operating Temperature Ranges
Current (any terminal)	30mA	MAX39_C_ _0°C to +70°C
Peak Current, COM_, NO_, NC_ (pulsed at 1ms, 10% duty cycle max)	100mA	MAX39_E_ _-40°C to +85°C
ESD per Method 3015.7	> 2000V	MAX39_M_ _-55°C to +125°C
Continuous Power Dissipation (TA = +70°C)		Storage Temperature Range
Plastic DIP (derate 10.53mW/°C above+70°C)	842mW	Lead Temperature (soldering, 10s)
	+300°C

Note 1: Signals on NC_, NO_, COM_, or IN_ exceeding V+ or V- are clamped by internal diodes. Limit forward diode current to maximum current rating.

Stresses beyond those listed under "Absolute Maximum Ratings" may cause permanent damage to the device. These are stress ratings only, and functional operation of the device at these or any other conditions beyond those indicated in the operational sections of the specifications is not implied. Exposure to absolute maximum rating conditions for extended periods may affect device reliability.

ELECTRICAL CHARACTERISTICS—Dual Supplies

(V+ = +5V ±10%, V- = -5V ±10%, GND = 0V, VINH = 2.4V, VINL = 0.8V, TA = TMIN to TMAX, unless otherwise noted.)

PARAMETER	SYMBOL	CONDITIONS	MIN	TYP (Note 2)	MAX	UNITS	
ANALOG SWITCH							
Analog Signal Range	VCOM_, VNO_, VNC_	(Note 3)	V-		V+	V	
On-Resistance	RON	V+ = 4.5V, V- = -4.5V, ICOM_ = -10mA, VNO_ or VNC_ = ±3.5V	TA = +25°C	C, E	20	35	Ω
				M	20	30	
			TA = TMIN to TMAX		45		
On-Resistance Match Between Channels (Note 4)	ΔRON	V+ = 5V, V- = -5V, ICOM_ = -10mA, VNO_ or VNC_ = ±3V	TA = +25°C		0.3	2	Ω
			TA = TMIN to TMAX		4		
On-Resistance Flatness (Note 5)	RFLAT(ON)	V+ = 5V, V- = -5V, ICOM_ = -10mA, VNO_ or VNC_ = ±3V	TA = +25°C		1	4	Ω
			TA = TMIN to TMAX		6		
NO or NC Off-Leakage Current (Note 6)	INO(OFF) or INC(OFF)	V+ = 5.5V, V- = -5.5V, VCOM_ = ±4.5V, VNO_ or VNC_ = ±4.5V	TA = +25°C		-0.1	±0.01	nA
			TA = TMIN to TMAX	C, E	-2.5	+2.5	
				M	-5	+5	
COM Off-Leakage Current (Note 6)	ICOM(OFF)	V+ = 5.5V, V- = -5.5V, VCOM_ = ±4.5V, VNO_ or VNC_ = ±4.5V	TA = +25°C		-0.1	±0.01	nA
			TA = TMIN to TMAX	C, E	-2.5	+2.5	
				M	-5	+5	
COM On-Leakage Current (Note 6)	ICOM(ON)	V+ = 5.5V, V- = -5.5V, VCOM_ = ±4.5V, VNO_ or VNC_ = ±4.5V	TA = +25°C		-0.2	±0.01	nA
			TA = TMIN to TMAX	C, E	-5.0	+5.0	
				M	-20	+20	

Precision, Quad, SPST Analog Switches

MAX391/MAX392/MAX393

ELECTRICAL CHARACTERISTICS—Dual Supplies (continued)

(V+ = +5V ±10%, V- = -5V ±10%, GND = 0V, VINH = 2.4V, VINL = 0.8V, TA = TMIN to TMAX, unless otherwise noted.)

PARAMETER	SYMBOL	CONDITIONS	MIN	TYP (Note 2)	MAX	UNITS
LOGIC INPUT						
Input Current with Input-Voltage High	I _{INH}	I _N = 2.4V, all others = 0.8V	-0.5	±0.005	+0.5	μA
Input Current with Input-Voltage Low	I _{INL}	I _N = 0.8V, all others = 2.4V	-0.5	±0.005	+0.5	μA
DYNAMIC						
Turn-On Time	t _{ON}	V _{COM_} = ±3V, Figure 2	T _A = +25°C		ns	
			T _A = T _{MIN} to T _{MAX}			
Turn-Off Time	t _{OFF}	V _{COM_} = ±3V, Figure 2	T _A = +25°C		ns	
			T _A = T _{MIN} to T _{MAX}			
Break-Before-Make Time Delay (Note 3)	t _D	MAX393 only, R _L = 300Ω, C _L = 35pF, Figure 3	5	10	ns	
Charge Injection (Note 3)	Q	C _L = 1.0nF, V _{GEN} = 0V, R _{GEN} = 0Ω, Figure 4	T _A = +25°C		pC	
Off-Isolation (Note 7)	OIRR	R _L = 50Ω, C _L = 5pF, f = 1MHz, Figure 5	T _A = +25°C		dB	
Crosstalk (Note 8)		R _L = 50Ω, C _L = 5pF, f = 1MHz, Figure 6	T _A = +25°C		dB	
NC or NO Capacitance	C _(OFF)	f = 1MHz, Figure 7	T _A = +25°C		pF	
COM Off-Capacitance	C _{COM(OFF)}	f = 1MHz, Figure 7	T _A = +25°C		pF	
COM On-Capacitance	C _{COM(ON)}	f = 1MHz, Figure 8	T _A = +25°C		pF	
SUPPLY						
Power-Supply Range			-8.0		+8.0	V
Positive Supply Current	I ₊	V ₊ = 5.5V, V ₋ = -5.5V, V _{IN} = 0V or V ₊ , all channels on or off	T _A = T _{MIN} to T _{MAX}		μA	
Negative Supply Current	I ₋	V ₊ = 5.5V, V ₋ = -5.5V, V _{IN} = 0V or V ₊ , all channels on or off	T _A = T _{MIN} to T _{MAX}		μA	

Precision, Quad, SPST Analog Switches

ELECTRICAL CHARACTERISTICS—Single +5V Supply

(V+ = +5V ±10%, V- = 0V ±10%, GND = 0V, VINH = 2.4V, VINL = 0.8V, TA = TMIN to TMAX, unless otherwise noted.)

PARAMETER	SYMBOL	CONDITIONS		MIN	TYP (Note 2)	MAX	UNITS
ANALOG SWITCH							
Analog Signal Range	VCOM_, VNO_, VNC_	(Note 3)		0		V+	V
On-Resistance	RON	V+ = 4.5V, ICOM_ = -10mA, VNO_ or VNC_ = 3.5V	TA = +25°C	30	60		Ω
			TA = TMIN to TMAX			75	
On-Resistance Match Between Channels (Note 4)	ΔRON	V+ = 5V, ICOM_ = -1.0mA, VNO_ or VNC_ = 3V	TA = +25°C	0.8	2		Ω
			TA = TMIN to TMAX			4	
On-Resistance Flatness (Notes 3, 5)	RFLAT(ON)	V+ = 5V, ICOM_ = -1.0mA, VNO_ or VNC_ = 1V, 3V	TA = +25°C	2	6		Ω
			TA = TMIN to TMAX			8	
NO or NC Off-Leakage Current (Note 9)	INO(OFF) or INC(OFF)	V+ = 5.5V, VCOM_ = 0V, VNO_ or VNC_ = 4.5V	TA = +25°C	-0.25	±0.01	+0.25	nA
			TA = TMIN to TMAX	C, E	-0.1	+0.1	
				M	-2.5	+2.5	
COM Off-Leakage Current (Note 9)	ICOM(OFF)	V+ = 5.5V, VCOM_ = 0V, VNO_ or VNC_ = 4.5V	TA = +25°C	-0.1	+0.1		nA
			TA = TMIN to TMAX	C, E	-2.5	+2.5	
				M	-5.0	+5.0	
COM On-Leakage Current (Note 9)	ICOM(ON)	V+ = 5.5V, VCOM_ = 5V, VNO_ or VNC_ = 4.5V	TA = +25°C	-0.2	+0.2		nA
			TA = TMIN to TMAX	C, E	-5.0	+5.0	
				M	-20	+20	
DYNAMIC							
Turn-On Time	tON	VNO_ or VNC_ = 3V	TA = +25°C	85	170		ns
			TA = TMIN to TMAX			240	
Turn-Off Time	tOFF	VNO_ or VNC_ = 3V	TA = +25°C	25	50		ns
			TA = TMIN to TMAX			100	
Break-Before-Make Time Delay (Note 3)	tD	MAX393 only, RL = 300Ω, CL = 35pF		10			ns
Charge Injection (Note 3)	Q	CL = 1.0nF, VGEN = 0V, RGEN = 0V, Figure 4	TA = +25°C	1	5		pC
SUPPLY							
Positive Supply Current	I+	V+ = 5.5V, VIN = 0V or V+, all channels on or off		-1		+1	μA
Negative Supply Current	I-	V+ = 5.5V, VIN = 0V or V+, all channels on or off		-1		+1	μA

Precision, Quad, SPST Analog Switches

MAX391/MAX392/MAX393

ELECTRICAL CHARACTERISTICS—Single +3.3V Supply

(V+ = +3.0V to +3.6V, GND = 0V, V_{INH} = 2.4V, V_{INL} = 0.8V, T_A = T_{MIN} to T_{MAX}, unless otherwise noted.)

PARAMETER	SYMBOL	CONDITIONS		MIN	TYP (Note 2)	MAX	UNITS
ANALOG SWITCH							
Analog Signal Range	V _{COM_} , V _{NO_} , V _{NC_}	(Note 3)		0		V+	V
Channel On-Resistance	R _{ON}	V+ = 3V, I _{COM_} = -1.0mA, V _{NO_} or V _{NC_} = 1.5V	T _A = +25°C	83	175		Ω
			T _A = T _{MIN} to T _{MAX}		275		
DYNAMIC							
Turn-On Time (Note 3)	t _{ON}	V _{NO_} or V _{NC_} = 1.5V	T _A = +25°C	160	400		ns
			T _A = T _{MIN} to T _{MAX}		500		
Turn-Off Time (Note 3)	t _{OFF}	V _{NO_} or V _{NC_} = 1.5V	T _A = +25°C	40	125		ns
			T _A = T _{MIN} to T _{MAX}		175		
Break-Before-Make Time Delay (Note 3)	t _D	MAX393 only, R _L = 300Ω, C _L = 35pF	T _A = +25°C	20			ns
Charge Injection (Note 3)	Q	C _L = 1.0nF, V _{GEN} = 0V, R _{GEN} = 0V	T _A = +25°C		1	5	pC
SUPPLY							
Positive Supply Current	I+	V+ = 3.6V, V _{IN} = 0V or V+, all channels on or off		-1		+1	μA
Negative Supply Current	I-	V+ = 3.6V, V _{IN} = 0V or V+, all channels on or off		-1		+1	μA

Note 2: The algebraic convention, where the most negative value is a minimum and the most positive value a maximum, is used in this data sheet.

Note 3: Guaranteed by design.

Note 4: $\Delta R_{ON} = \Delta R_{ON\ max} - \Delta R_{ON\ min}$.

Note 5: Flatness is defined as the difference between the maximum and minimum value of on-resistance as measured over the specified analog signal range.

Note 6: Leakage parameters are 100% tested at maximum rated hot temperature and guaranteed by correlation at +25°C.

Note 7: Off-isolation = 20 log₁₀ [V_{COM_} / (V_{NC_} or V_{NO_})], V_{COM_} = output, V_{NC_} or V_{NO_} = input to off switch.

Note 8: Between any two switches.

Note 9: Leakage testing at single supply is guaranteed by testing with dual singles.

Precision, Quad, SPST Analog Switches

Typical Operating Characteristics

($T_A = +25^\circ\text{C}$, unless otherwise noted.)

FORWARD SHUTDOWN CURRENT vs. TEMPERATURE

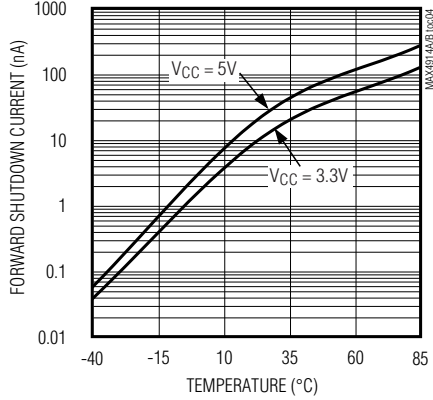

RON vs. VCOM AND TEMPERATURE (DUAL SUPPLIES)

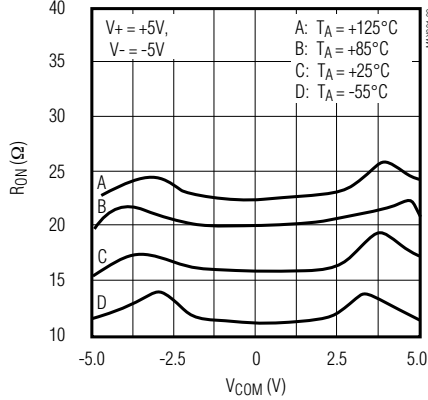

RON vs. VCOM (SINGLE SUPPLY)

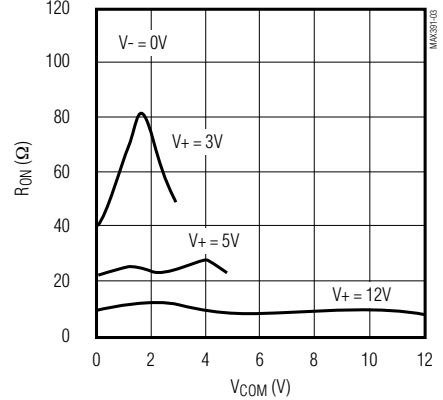

RON vs. VCOM AND TEMPERATURE (SINGLE SUPPLY)

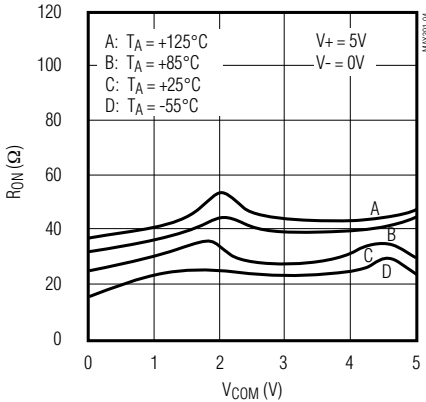

OFF-LEAKAGE CURRENT vs. TEMPERATURE

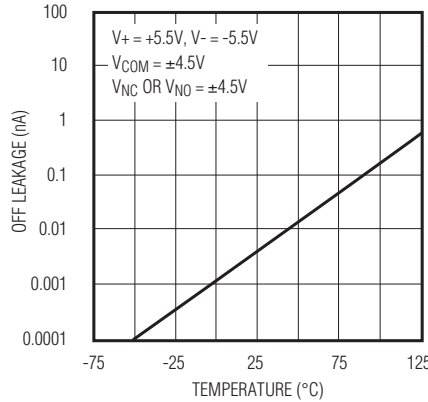

ON-LEAKAGE CURRENT vs. TEMPERATURE

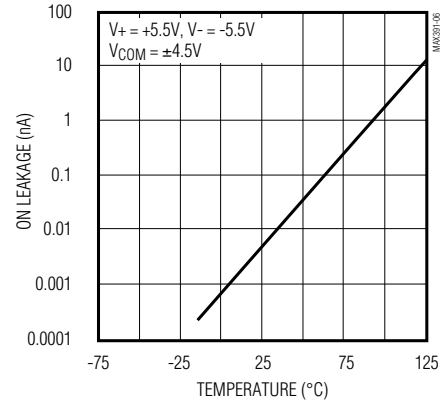

CHARGE INJECTION vs. VCOM

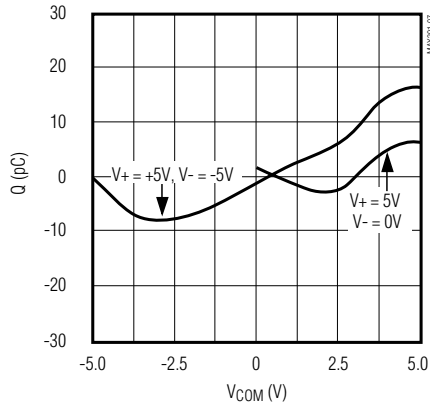

SUPPLY CURRENT vs. TEMPERATURE

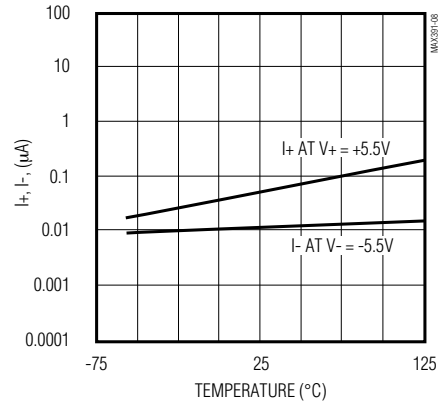

Precision, Quad, SPST Analog Switches

Pin Description

PIN		NAME	FUNCTION
DIP/SO/TSSOP	QFN		
1, 16, 9, 8	15, 14, 7, 6	IN1–IN4	Inputs
2, 15, 10, 7	16, 13, 8, 5	COM1–COM	Analog Switch Common Terminal
3, 14, 11, 6	1, 12, 9, 4	NO1–NO4 or NC1–NC4	Switch Inputs
4	2	V-	Negative-Supply Voltage Input
5	3	GND	Ground
12	10	N.C.	No Connection. Not internally connected
13	11	V+	Positive-Supply Voltage Input—connected to substrate
—	EP	EP	Exposed Pad. Connect to V+.

Applications Information

Overvoltage Protection

Proper power-supply sequencing is recommended for all CMOS devices. Do not exceed the absolute maximum ratings, because stresses beyond the listed ratings may cause permanent damage to the devices. Always sequence V+ on first, followed by V-, and then logic inputs. If power-supply sequencing is not possible, add two small signal diodes in series with supply pins for overvoltage protection (Figure 1). Adding diodes reduces the analog signal range to 1V below V+ and 1V below V-, but low switch resistance and low leakage characteristics are unaffected. Device operation is unchanged, and the difference between V+ and V- should not exceed 17V.

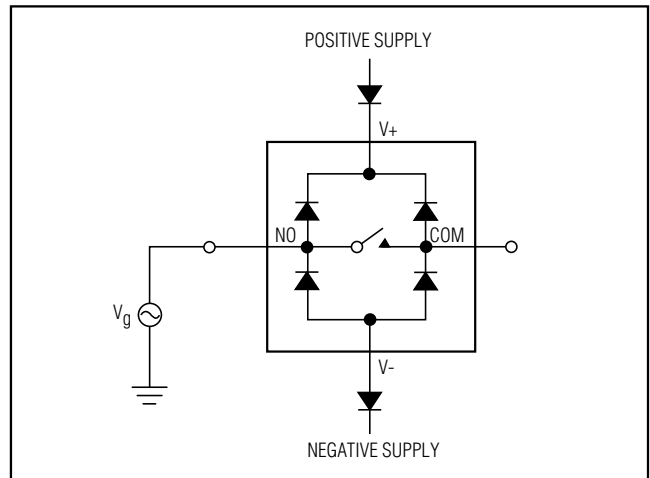

Figure 1. Overvoltage Protection Using Two External Blocking Diodes

MAX391/MAX392/MAX393

Precision, Quad, SPST Analog Switches

Test Circuits/Timing Diagrams

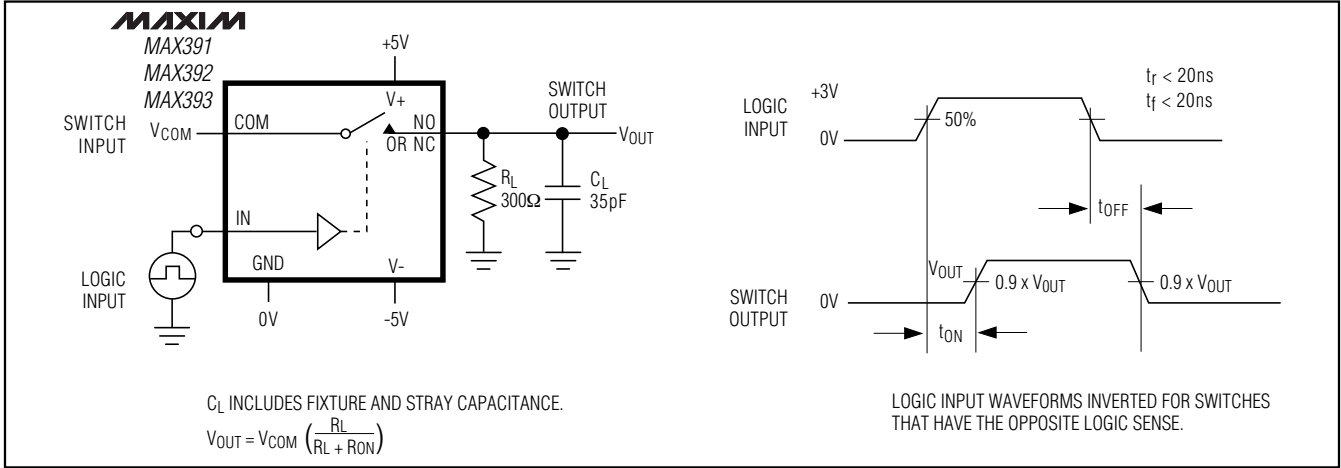

Figure 2. Switching Time

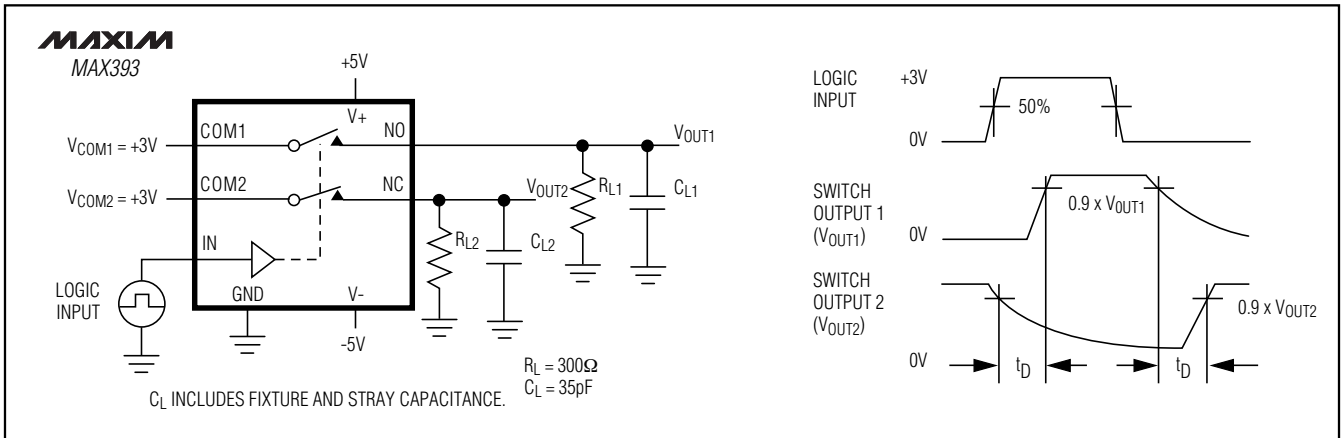

Figure 3. Break-Before-Make Interval (MAX393 only)

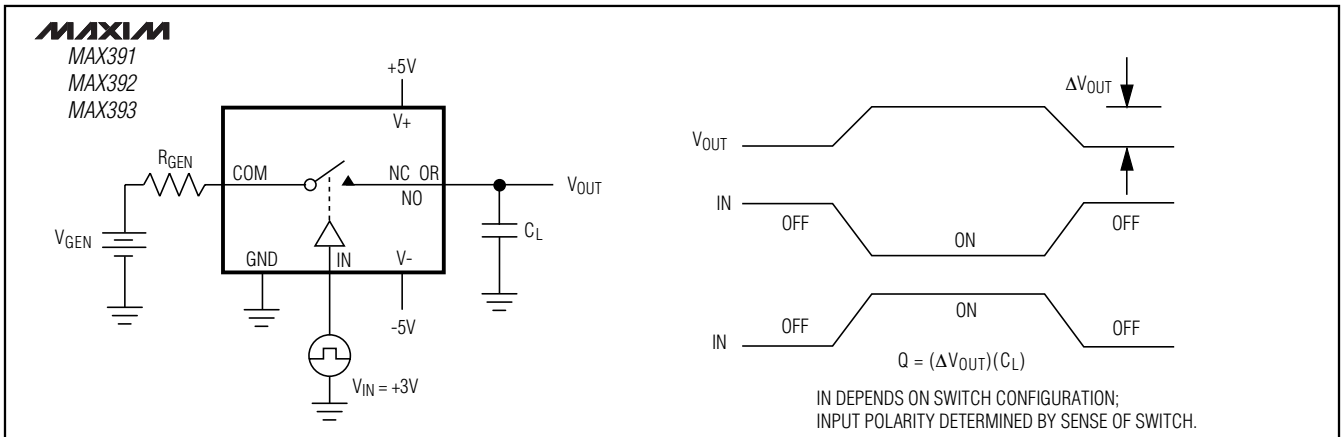

Figure 4. Charge Injection

Precision, Quad, SPST Analog Switches

Test Circuits/Timing Diagrams (continued)

MAX391/MAX392/MAX393

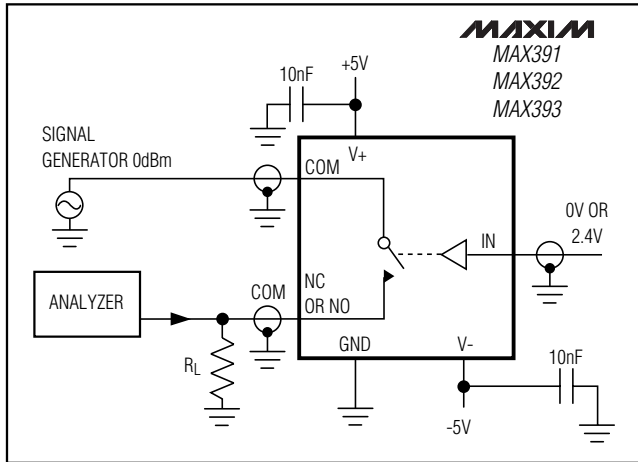

Figure 5. Off-Isolation

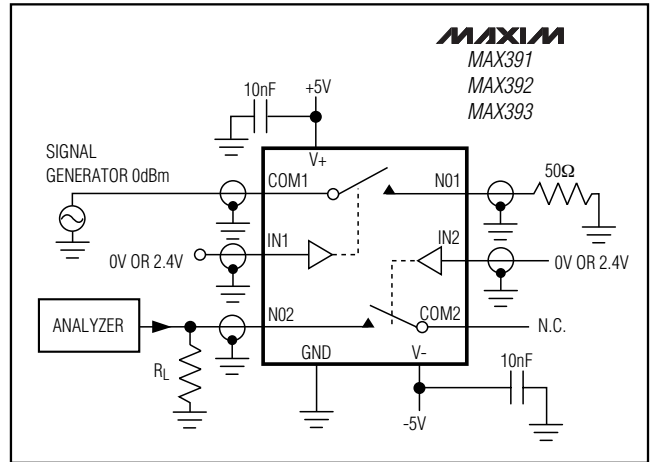

Figure 6. Crosstalk

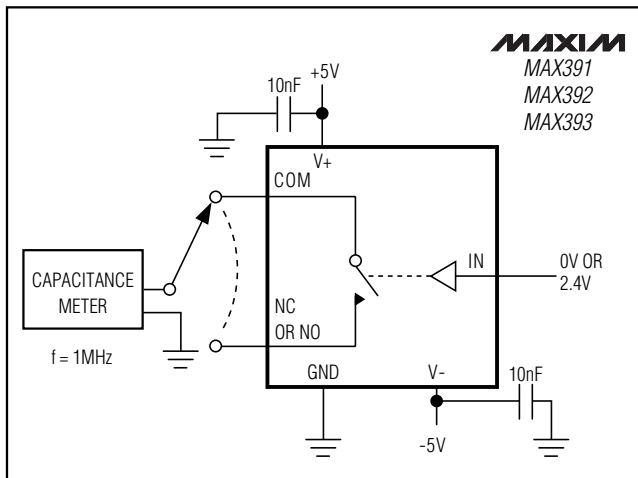

Figure 7. Channel Off-Capacitance

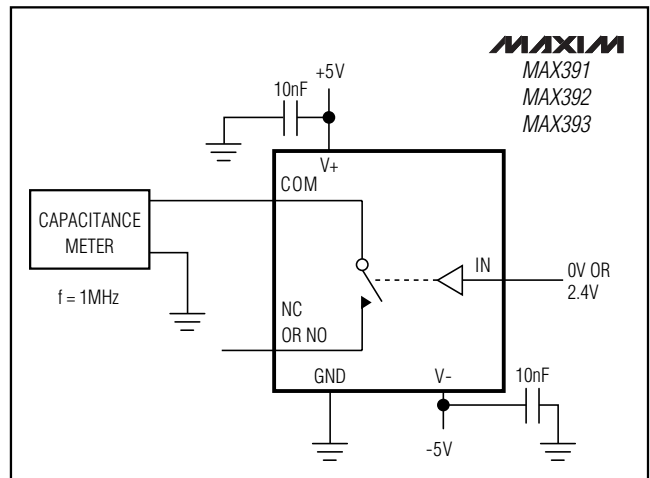

Figure 8. Channel On-Capacitance

Precision, Quad, SPST Analog Switches

Ordering Information (continued)

PART	TEMP RANGE	PIN-PACKAGE	PKG CODE
MAX391ESE	-40°C to +85°C	16 Narrow SO	S16-2
MAX391EUE	-40°C to +85°C	16 TSSOP	U16-2
MAX391EGE	-40°C to +85°C	16 QFN-EP†	G1655-3
MAX391EJE	-40°C to +85°C	16 CERDIP	J16-3
MAX391MJE	-55°C to +125°C	6 CERDIP**	—
MAX392CPE	0°C to +70°C	16 Plastic DIP	P16-1
MAX392CSE	0°C to +70°C	16 Narrow SO	S16-2
MAX392CUE	0°C to +70°C	16 TSSOP	U16-2
MAX392CGE	0°C to +70°C	16 QFN-EP†	G1655-3
MAX392C/D	0°C to +70°C	Dice*	—
MAX392EPE	-40°C to +85°C	16 Plastic DIP	P16-1
MAX392ESE	-40°C to +85°C	16 Narrow SO	S16-2
MAX392EUE	-40°C to +85°C	16 TSSOP	U16-2
MAX392EGE	-40°C to +85°C	16 QFN	G1655-3
MAX392EJE	-40°C to +85°C	16 CERDIP	J16-3
MAX392MJE	-55°C to +125°C	6 CERDIP**	—
MAX393CPE	0°C to +70°C	16 Plastic DIP	P16-1
MAX393CSE	0°C to +70°C	16 Narrow SO	S16-2
MAX393CUE	0°C to +70°C	16 TSSOP	U16-2
MAX393CGE	0°C to +70°C	16 QFN-EP†	G1655-3
MAX393C/D	0°C to +70°C	Dice*	—
MAX393EPE	-40°C to +85°C	16 Plastic DIP	P16-1
MAX393ESE	-40°C to +85°C	16 Narrow SO	S16-2
MAX393EUE	-40°C to +85°C	16 TSSOP	U16-2
MAX393EGE	-40°C to +85°C	16 QFN-EP†	G1655-3
MAX393EJE	-40°C to +85°C	16 CERDIP	J16-3
MAX393MJE	-55°C to +125°C	6 CERDIP**	—

*Contact factory for dice specifications.

**Contact factory for availability and processing to MIL-STD-883.

†EP = Exposed pad.

Chip Topography

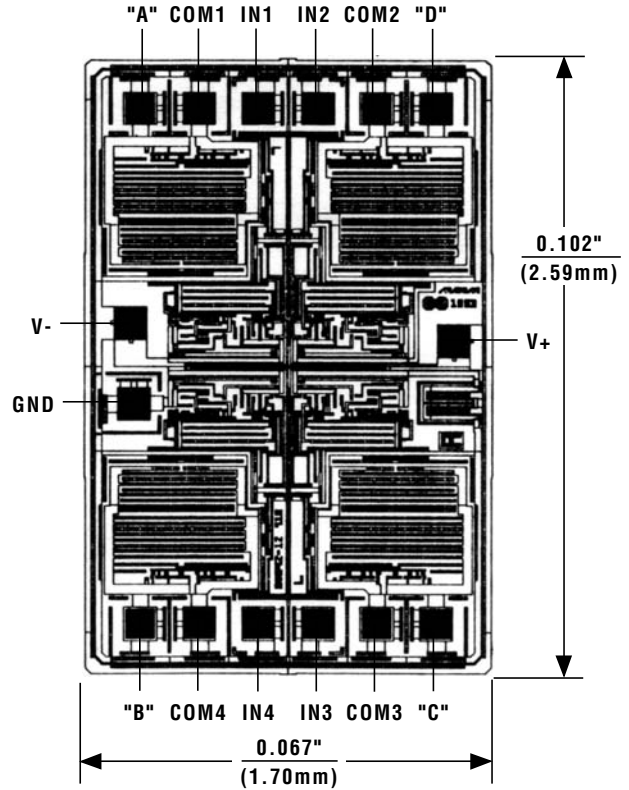

MAX391		MAX392		MAX393	
PIN	NAME	PIN	NAME	PIN	NAME
A	NC1	A	N01	A	N01
B	NC4	B	N04	B	N04
C	NC3	C	N03	C	NC3
D	NC2	D	N02	D	NC2

TRANSISTOR COUNT: 76

SUBSTRATE CONNECTED TO V+

Precision, Quad, SPST Analog Switches

Pin Configurations/Functional Diagrams/Truth Tables (continued)

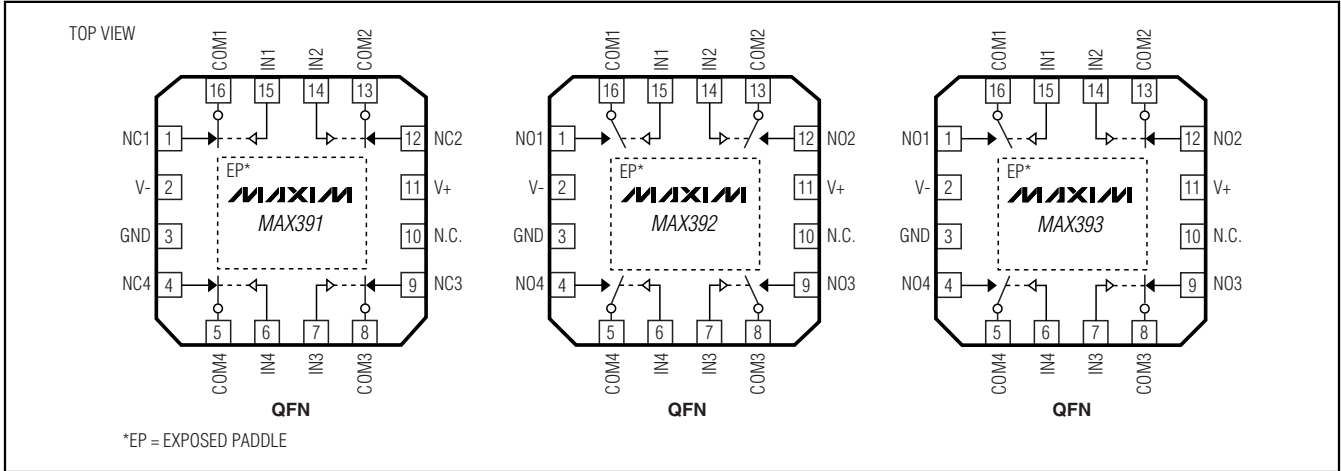

Package Information

(The package drawing(s) in this data sheet may not reflect the most current specifications. For the latest package outline information go to www.maxim-ic.com/packages.)

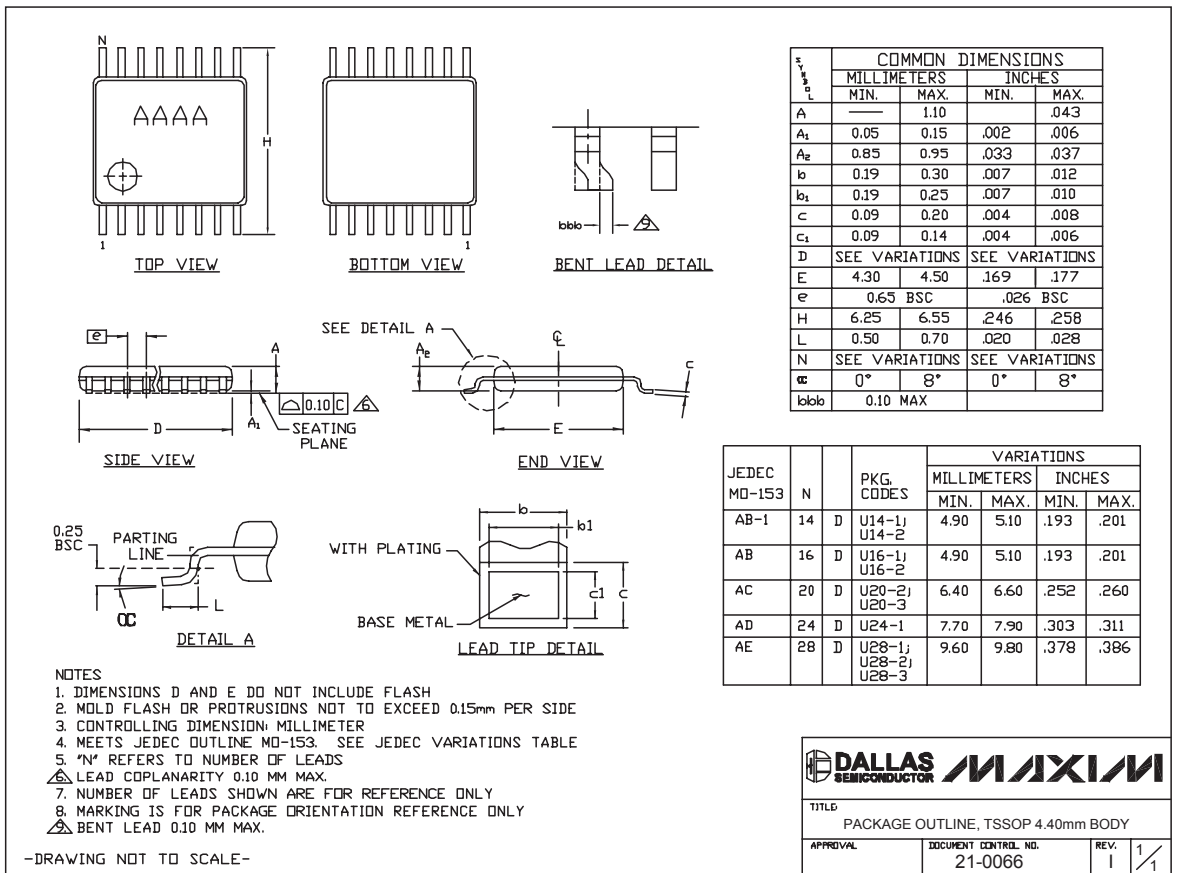

MAX391/MAX392/MAX393

TSSOP4.40mm EP

Precision, Quad, SPST Analog Switches

Package Information (continued)

(The package drawing(s) in this data sheet may not reflect the most current specifications. For the latest package outline information go to www.maxim-ic.com/packages.)

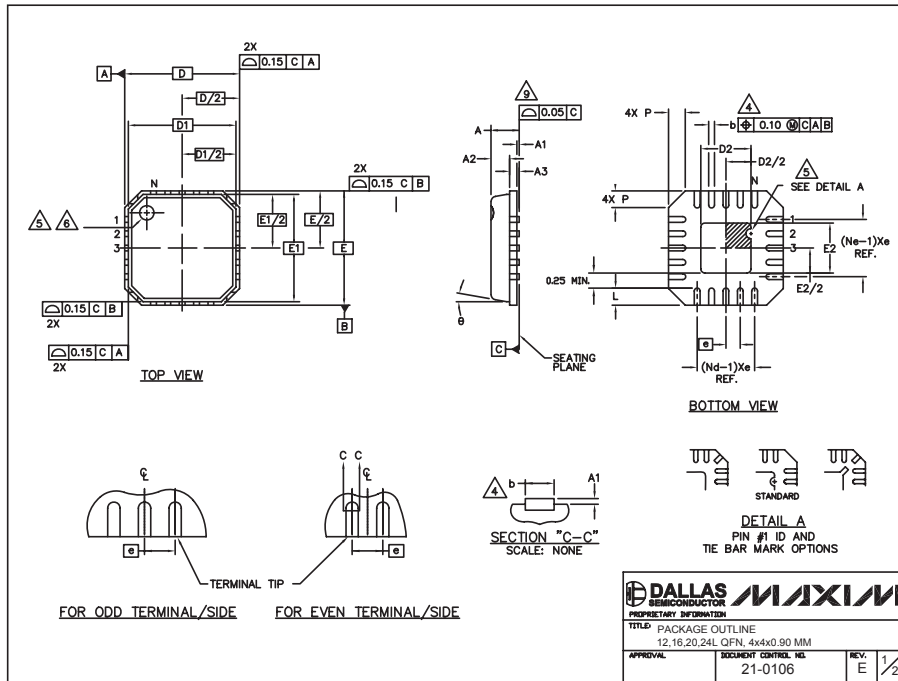

12,16,20, 24L QFN/EPS

NOTES:

- DIE THICKNESS ALLOWABLE IS 0.305mm MAXIMUM (.012 INCHES MAXIMUM).
- DIMENSIONING & TOLERANCES CONFORM MUST TO ASME Y14.5M. - 1994.
- N IS THE NUMBER OF TERMINALS.
Nd IS THE NUMBER OF TERMINALS IN X-DIRECTION &
Ne IS THE NUMBER OF TERMINALS IN Y-DIRECTION.
- DIMENSION b APPLIES TO PLATED TERMINAL AND IS MEASURED BETWEEN 0.20 AND 0.25mm FROM TERMINAL TIP.
- THE PIN #1 IDENTIFIER MUST BE EXISTED ON THE TOP SURFACE OF THE PACKAGE BY USING INDENTATION MARK OR INK/LASER MARKED. DETAILS OF PIN #1 IDENTIFIER IS OPTIONAL, BUT MUST BE LOCATED WITHIN ZONE INDICATED.
- EXACT SHAPE AND SIZE OF THIS FEATURE IS OPTIONAL.
- ALL DIMENSIONS ARE IN MILLIMETERS.
- PACKAGE WARPAGE MAX 0.05mm.
- APPLIED FOR EXPOSED PAD AND TERMINALS. EXCLUDE EMBEDDING PART OF EXPOSED PAD FROM MEASURING.
- MEETS JEDEC MO220; EXCEPT DIMENSION "b".
- THIS PACKAGE OUTLINE APPLIES TO PUNCHED QFN (STEPPED SIDES).

DIM.	COMMON DIMENSIONS			No. of
	MIN.	NOM.	MAX.	
A	0.80	0.90	1.00	
A1	0.00	0.01	0.05	
A2	0.00	0.65	0.80	
A3	0.20 REF.			
D	4.00 BSC			
D1	3.75 BSC			
E	4.00 BSC			
E1	3.75 BSC			
b	0"	-	12"	
P	0.24	0.42	0.60	

PKG. CODE	PITCH VARIATION A			No. of	No. of	PITCH VARIATION B			No. of	No. of	PITCH VARIATION C			No. of	No. of	PITCH VARIATION D		
	MIN.	NOM.	MAX.			MIN.	NOM.	MAX.			MIN.	NOM.	MAX.			MIN.	NOM.	MAX.
	0.60 BSC			3	N	0.65 BSC			3	N	0.50 BSC			3	N	0.50 BSC		
N	12			3	N	16			3	N	20			3	N	24		
Nd	3			3	Nd	4			3	Nd	5			3	Nd	6		
Ne	3			3	Ne	4			3	Ne	5			3	Ne	6		
L	0.50	0.60	0.75	11	L	0.50	0.60	0.75	11	L	0.50	0.60	0.75	11	L	0.30	0.40	0.50
b	0.28	0.33	0.40	4	b	0.23	0.28	0.35	4	b	0.18	0.23	0.30	4	b	0.18	0.23	0.30

PKG. CODE	EXPOSED PAD VARIATION D2			EXPOSED PAD VARIATION E2		
	MIN.	NOM.	MAX.	MIN.	NOM.	MAX.
G1244-2	1.95	2.10	2.25	1.95	2.10	2.25
G1644-1	1.95	2.10	2.25	1.95	2.10	2.25
G2044-3	1.95	2.10	2.25	1.95	2.10	2.25
G2044-4	1.55	1.70	1.85	1.55	1.70	1.85
G2444-1	1.95	2.10	2.25	1.95	2.10	2.25

DALLAS MAXIM SEMICONDUCTOR
 PROPRIETARY INFORMATION
 TITLE: PACKAGE OUTLINE
 12,16,20,24L QFN, 4x4x0.90 MM
 APPROVAL: [] DOCUMENT CONTROL: 21-0106 REV: E 2/2

Precision, Quad, SPST Analog Switches

Package Information (continued)

(The package drawing(s) in this data sheet may not reflect the most current specifications. For the latest package outline information go to www.maxim-ic.com/packages.)

MAX391/MAX392/MAX393

SOICN .EPS

DIM	INCHES		MILLIMETERS	
	MIN	MAX	MIN	MAX
A	0.053	0.069	1.35	1.75
A1	0.004	0.010	0.10	0.25
B	0.014	0.019	0.35	0.49
C	0.007	0.010	0.19	0.25
e	0.050 BSC		1.27 BSC	
E	0.150	0.157	3.80	4.00
H	0.228	0.244	5.80	6.20
L	0.016	0.050	0.40	1.27

VARIATIONS:

DIM	INCHES		MILLIMETERS		N	MS012
	MIN	MAX	MIN	MAX		
D	0.189	0.197	4.80	5.00	8	AA
D	0.337	0.344	8.55	8.75	14	AB
D	0.386	0.394	9.80	10.00	16	AC

NOTES:

1. D&E DO NOT INCLUDE MOLD FLASH.
2. MOLD FLASH OR PROTRUSIONS NOT TO EXCEED 0.15mm (.006").
3. LEADS TO BE COPLANAR WITHIN 0.10mm (.004").
4. CONTROLLING DIMENSION: MILLIMETERS.
5. MEETS JEDEC MS012.
6. N = NUMBER OF PINS.

<small>PROPRIETARY INFORMATION</small> TITLE: PACKAGE OUTLINE, .150" SOIC	
APPROVAL	DOCUMENT CONTROL NO. 21-0041
REV. B	1/1

Revision History

Pages changed at Rev 3: 1-11, 13

Maxim cannot assume responsibility for use of any circuitry other than circuitry entirely embodied in a Maxim product. No circuit patent licenses are implied. Maxim reserves the right to change the circuitry and specifications without notice at any time.

13 Maxim Integrated Products, 120 San Gabriel Drive, Sunnyvale, CA 94086 (408) 737-7600

© 2006 Maxim Integrated Products

MAXIM is a registered trademark of Maxim Integrated Products, Inc.