

Ambient and Infrared Proximity Sensor

General Description

The MAX44000 combines a wide-dynamic range ambient light sensor with an integrated infrared proximity sensor. The IC is a perfect solution for touch-screen portable devices.

The IC can consume as low as 11 μ A (time averaged) in ambient light sensing plus proximity sensing, including external IR LED current.

The on-chip ambient sensor has the ability to make wide dynamic range 0.03 lux to 65,535 lux measurements. An on-chip IR proximity detector is matched with an integrated IR LED driver. All readings are available on an I²C communication bus. A programmable interrupt pin minimizes the need to poll the device for data, freeing up microcontroller resources, reducing system software overhead, and ultimately, reducing power consumption.

The IC is designed to drive an external IR LED and can operate from a V_{DD} of 1.7V to 3.6V. It consumes just 5 μ A operating current when only the ambient light sensor is enabled and 7 μ A when the proximity receiver and driver are enabled.

Applications

Smartphones
Accessories
Industrial Sensors
Presence Detection

Features

- ◆ Tiny, 2mm x 2mm x 0.6mm UTDFN-Opto Package
- ◆ V_{DD} = 1.7V to 3.6V
- ◆ Low-Power Operation
 - 5 μ A in Ambient Mode
 - 7 μ A in Ambient Plus Proximity Mode
 - 70 μ A in Ambient Plus Proximity Mode, Including 100mA LED Current
- ◆ Excellent Light Source Matching
Programmable Green and IR Channel Gains
- ◆ Integrated Single-Pulse IR LED Driver
10mA to 110mA Programmable Range
Internal Ambient Cancellation
- ◆ -40°C to +105°C Temperature Range

Ordering Information

PART	TEMP RANGE	PIN-PACKAGE
MAX44000GDT+	-40°C to +105°C	6 OTDFN-EP*

+Denotes a lead(Pb)-free/RoHS-compliant package.

*EP = Exposed pad.

Typical Application Circuit appears at end of data sheet.

Simplified Block Diagram

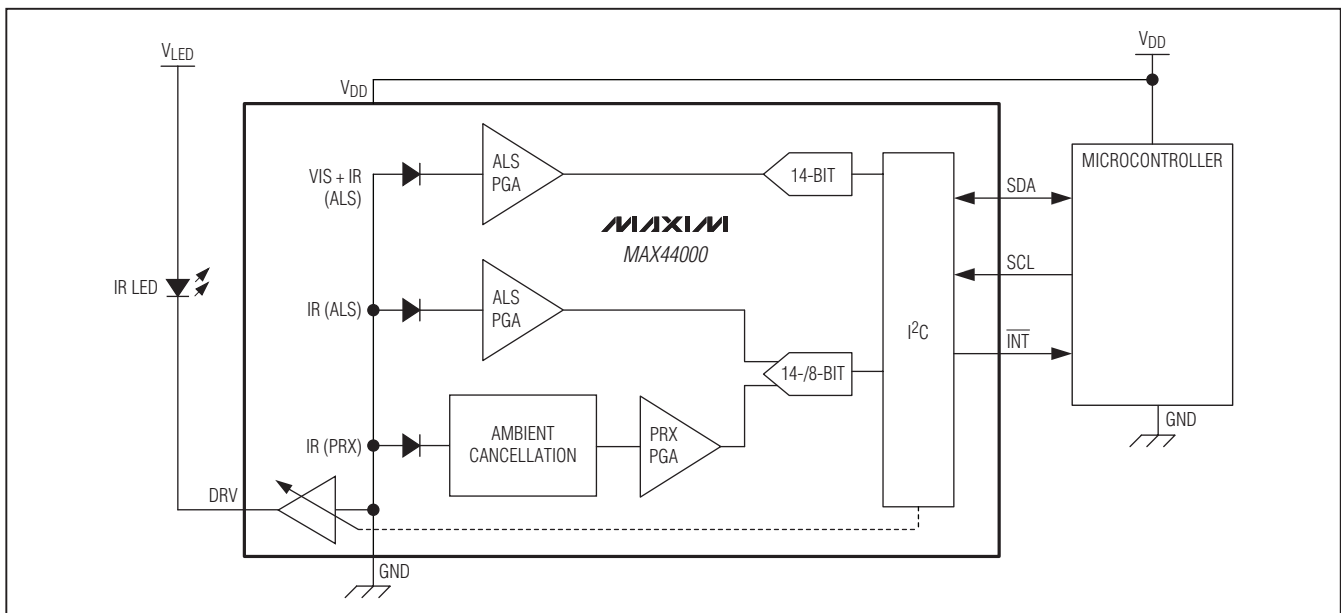

Ambient and Infrared Proximity Sensor

ABSOLUTE MAXIMUM RATINGS

All Pins to GND	-0.3V to +4.0V	Continuous Power Dissipation (T _A = +70°C)	
Output Short-Circuit Current Duration.....	Continuous	6-Pin OTDFN (derate 11.9mW/°C above +70°C)	953mW
Continuous Input Current into Any Terminal.....	±20mA	Operating Temperature Range	-40°C to +105°C
		Soldering Temperature (reflow)	+260°C

Stresses beyond those listed under "Absolute Maximum Ratings" may cause permanent damage to the device. These are stress ratings only, and functional operation of the device at these or any other conditions beyond those indicated in the operational sections of the specifications is not implied. Exposure to absolute maximum rating conditions for extended periods may affect device reliability.

ELECTRICAL CHARACTERISTICS

(V_{DD} = 1.8V, T_{MIN} – T_{MAX} = -40°C to +105°C, T_A = +25°C, unless otherwise noted.) (Note 1)

PARAMETER	SYMBOL	CONDITIONS	MIN	TYP	MAX	UNITS
AMBIENT LIGHT RECEIVER CHARACTERISTICS						
Maximum Ambient Light Sensitivity		Fluorescent light (Note 2)		0.03		Lux/LSB
Ambient Light Saturation Level				65,535		Lux
Gain Error		Green LED 538nm response, T _A = +25°C (Note 2)			15	%
Light Source Matching		Fluorescent/incandescent light		10		%
Infrared Transmittance		850nm vs. 538nm, T _A = +25°C		0.5		%
Ultraviolet Transmittance		363nm vs. 538nm, T _A = +25°C		2		%
Dark Current Level		100ms conversion time, 0 lux, T _A = +25°C		0		Count
ADC Conversion Time		14-bit resolution, has 50Hz/60Hz rejection		100		ms
		12-bit resolution		25		
		10-bit resolution		6.25		
		8-bit resolution		1.56		
ADC Conversion Time Accuracy		T _A = -40°C to +105°C			6	%
		T _A = +25°C			0.7	
INFRARED PROXIMITY RECEIVER CHARACTERISTICS						
Maximum Proximity Detection Sensitivity		850nm IR LED, 60μW/cm ²		1.5		μW/cm ² /LSB
Sunlight Rejection Offset		No reflector 0 to 100k lux		0		Counts
Sunlight Rejection Gain Error		With reflector 0 to 100k lux		0.1		Counts/klux

Ambient and Infrared Proximity Sensor

MAX44000

ELECTRICAL CHARACTERISTICS (continued)

(V_{DD} = 1.8V, T_{MIN} – T_{MAX} = -40°C to +105°C, T_A = +25°C, unless otherwise noted.) (Note 1)

PARAMETER	SYMBOL	CONDITIONS	MIN	TYP	MAX	UNITS
IR LED TRANSMITTER						
Minimum IR LED Drive Current Sink				10		mA
Maximum IR LED Drive Current Sink				110		mA
Current Control Step				10		mA
Current Control Accuracy		I _{OUT} = 110mA, V _{DRV} = 1.5V			12	%
		I _{OUT} = 50mA, V _{DRV} = 1.5V			10	
		I _{OUT} = 10mA, V _{DRV} = 1.5V			12	
DRV Leakage Current		I _{OUT} = 0mA, V _{DRV} = 3.6V			0.1	μA
Voltage Compliance of DRV Pin		I _{DRV} = 110mA, ΔI _{OUT} = 10%; V _{DRV} = 3.6V			0.5	V
		I _{DRV} = 100mA, ΔI _{OUT} = 2%, V _{DRV} = 3.6V			0.6	
Internal Transmit Pulse Width				100		μs
POWER SUPPLY						
Power-Supply Voltage	V _{DD}		1.7		3.6	V
Quiescent Current (Ambient Mode)	I _s			5	10	μA
Software Shutdown Current	I _{SHDN}	T _A = +25°C		0.1	0.3	μA
		T _A = -40°C to +105°C			0.6	
Quiescent Current Proximity		During IR LED pulsed operation		375	600	μA
Quiescent Current (ALS + Proximity, Time Average)		With proximity and ALS sensing on		6.8		μA
Power-Up Time	t _{ON}			100		ms
DIGITAL CHARACTERISTICS (SDA, SCL, INT)						
Output Low Voltage (SDA, INT)	V _{OL}	I _{SINK} = 6mA		0.06	0.4	V
INT Leakage Current				0.01	1000	nA
SDA, SCL Input Current				0.01	1000	nA
I ² C Input Low Voltage	V _{IL_I2C}	SDA, SCL			0.4	V
I ² C Input High Voltage	V _{IH_I2C}	SDA, SCL	1.6			V
Input Capacitance				3		pF

Ambient and Infrared Proximity Sensor

ELECTRICAL CHARACTERISTICS (continued)

($V_{DD} = 1.8V$, $T_{MIN} - T_{MAX} = -40^{\circ}C$ to $+105^{\circ}C$, $T_A = +25^{\circ}C$, unless otherwise noted.) (Note 1)

PARAMETER	SYMBOL	CONDITIONS	MIN	TYP	MAX	UNITS
I²C TIMING CHARACTERISTICS						
Serial-Clock Frequency	f_{SCL}				400	kHz
Bus Free Time Between STOP and START	t_{BUF}		1.3			μs
Hold Time (Repeated) START Condition	$t_{HD,STA}$		0.6			μs
Low Period of the SCL Clock	t_{LOW}		1.3			μs
High Period of the SCL Clock	t_{HIGH}		0.6			μs
Setup Time for a REPEATED START	$t_{SU,STA}$		0.6			μs
Data Hold Time	$t_{HD,DAT}$		0		0.9	μs
Data Setup Time	$t_{SU,DAT}$		100			ns
SDA Transmitting Fall Time	t_F	$I_{SINK} \leq 6mA$, t_R and t_F between $0.3 \times V_{DD}$ and $0.7 \times V_{DD}$		100		ns
Setup Time for STOP Condition	$t_{SU,STO}$		0.6			μs
Pulse Width of Suppressed Spike	t_{SP}		0		50	ns

Note 1: All devices are 100% production tested at $T_A = +25^{\circ}C$. Temperature limits are guaranteed by design.

Note 2: Guaranteed by design. Green 538nm LED chosen for production so that the IC responds to 100 lux fluorescent light with 100 lux.

Typical Operating Characteristics

($V_{DD} = 1.8V$, $T_{MIN} - T_{MAX} = -40^{\circ}C$ to $+85^{\circ}C$, unless otherwise noted. All devices are 100% production tested at $T_A = +25^{\circ}C$. Temperature limits are guaranteed by design.)

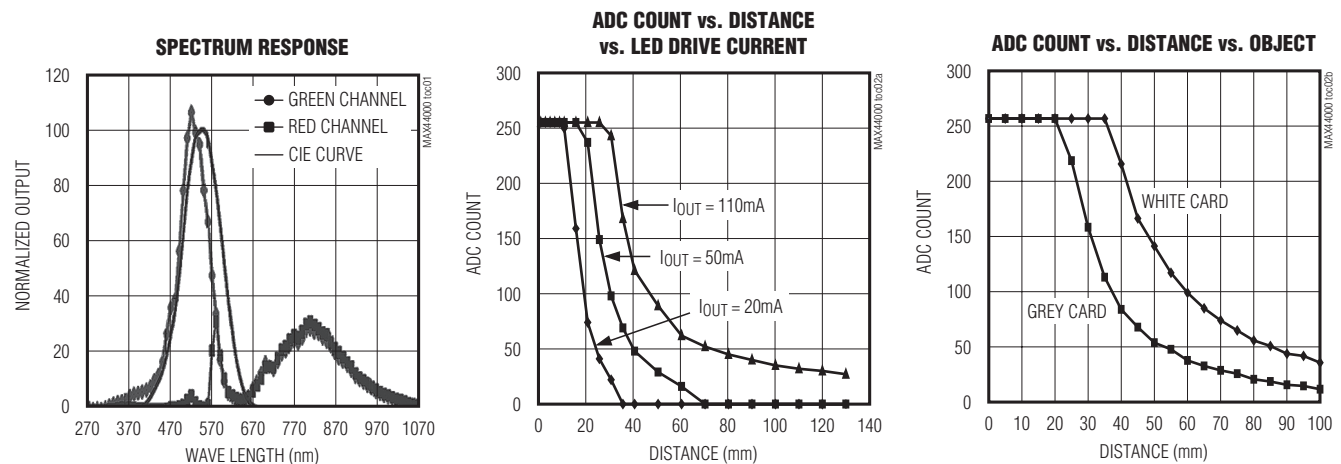

Ambient and Infrared Proximity Sensor

MAX44000

Typical Operating Characteristics (continued)

(V_{DD} = 1.8V, T_{MIN} - T_{MAX} = -40°C to +85°C, unless otherwise noted. All devices are 100% production tested at T_A = +25°C. Temperature limits are guaranteed by design.)

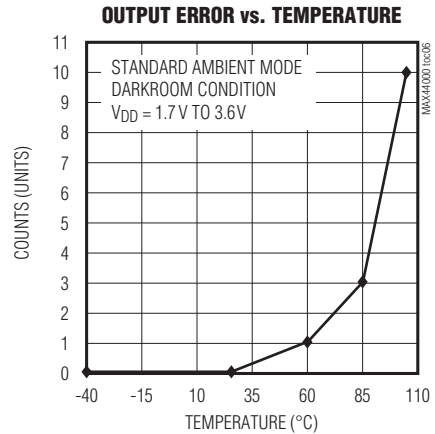
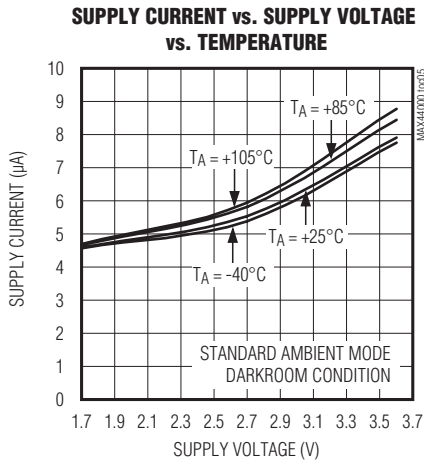
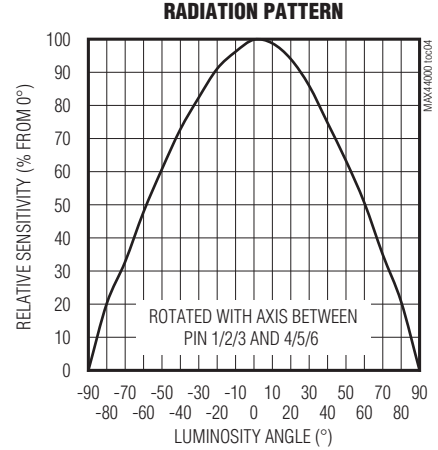
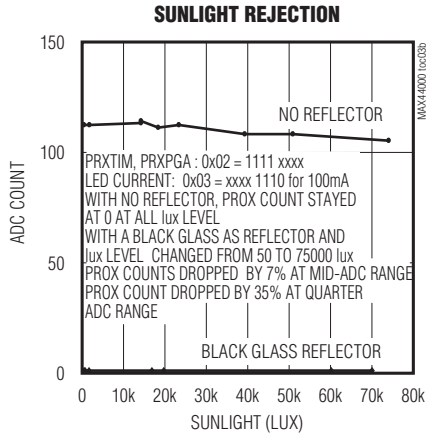
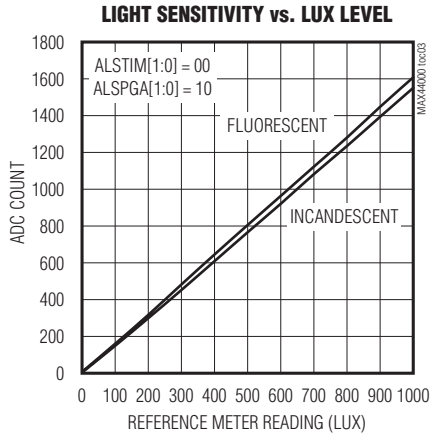

Ambient and Infrared Proximity Sensor

Typical Operating Characteristics (continued)

(V_{DD} = 1.8V, T_{MIN} – T_{MAX} = -40°C to +85°C, unless otherwise noted. All devices are 100% production tested at T_A = +25°C. Temperature limits are guaranteed by design.)

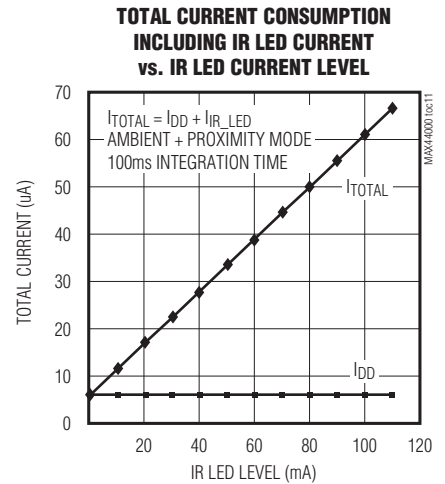
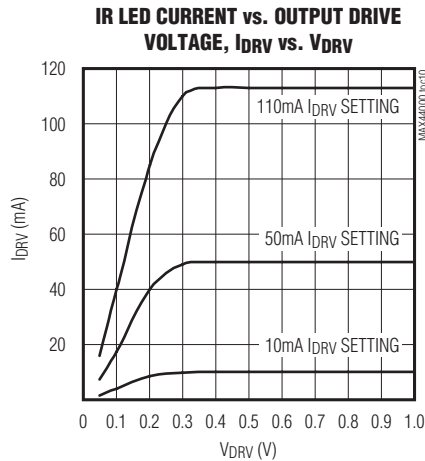
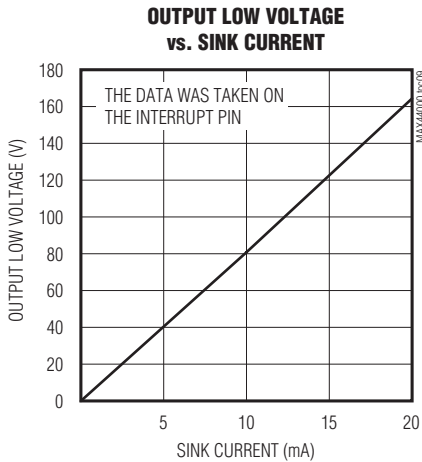
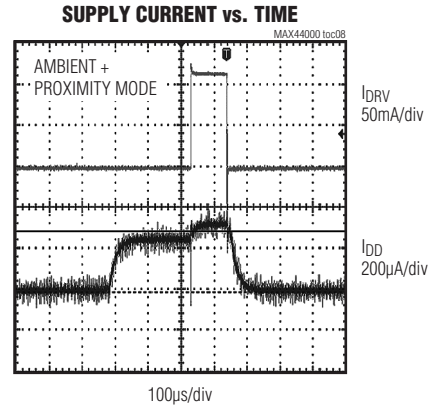
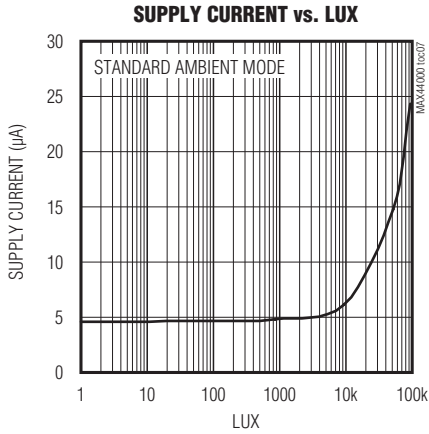

Ambient and Infrared Proximity Sensor

MAX44000

Pin Configuration

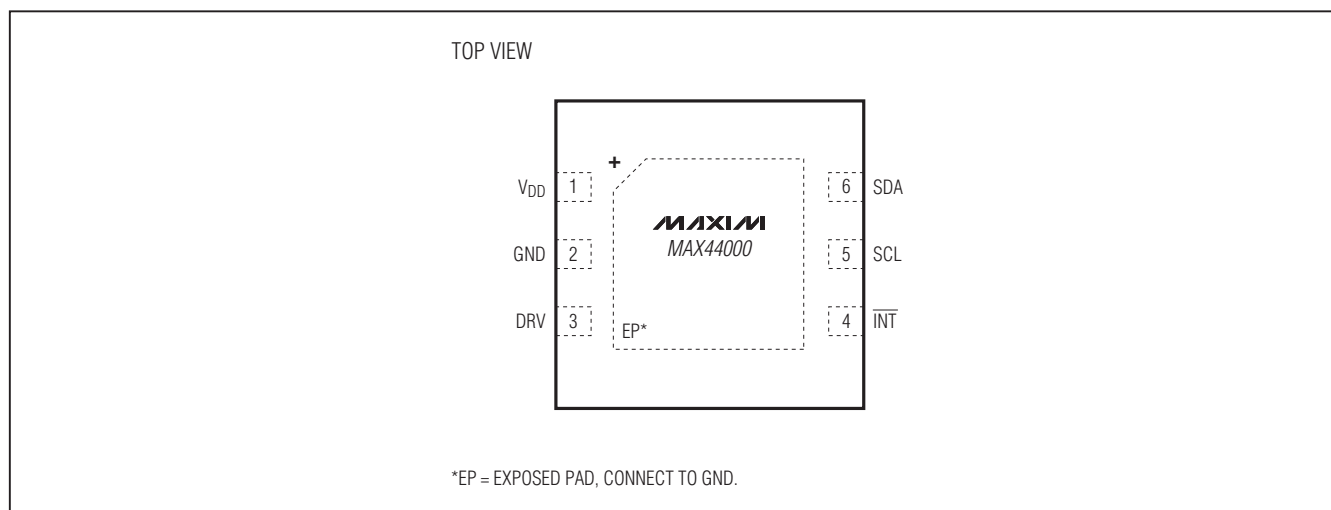

Pin Description

PIN	NAME	FUNCTION
1	VDD	Power Supply
2	GND	Ground
3	DRV	IR LED Current Driver
4	INT	Interrupt. Active-low output.
5	SCL	I ² C Clock
6	SDA	I ² C Data
EP	—	Exposed Pad. EP is internally connected to GND. EP must be connected to GND.

Detailed Description

The MAX44000 combines a wide-dynamic range ambient light sensor with an integrated infrared proximity sensor. The die is placed inside an optically transparent (UTDFN-Opto) package. A photodiode array inside the IC converts the light to a current, which is then processed by low-power circuitry into a digital value. The data is then stored in an output register that is read by an I²C interface.

The IC contains three types of photodiodes: a green photodiode and two types of infrared photodiodes. Ambient light sensing (ALS) is accomplished by subtracting the infrared ALS photodiode signal from the green ALS photodiode signals after applying respective gains. The

infrared proximity photodiodes are optimized for better sensitivity for near infrared signals, specifically 850nm, and can be used for proximity sensor measurements.

In the ALS mode, the ALS photodiodes are connected to two ADCs. The user can choose to view either just the green ALS signal, or just the infrared ALS signal, or the difference of the green and infrared ALS photodiodes.

In the proximity detect mode, the infrared proximity photodiodes are connected to the proximity receiver circuit and then to an 8-bit ADC.

Three key features of the IC's analog design are its low-power design, single-pulse proximity receive operation, and interrupt pin operation.

Ambient and Infrared Proximity Sensor

The IC operates from a V_{DD} of 1.7V to 3.6V and consumes just $5\mu\text{A}$ current in ALS mode and $7\mu\text{A}$ time-averaged in proximity mode. The on-chip IR proximity detector DC ambient rejection circuitry is synchronized with pulsing of an integrated IR LED transmitter to improve noise immunity from external fluctuating IR sources. This scheme also reduces IR LED power consumption compared to alternate methods and eliminates red-glow problems with the use of 850nm IR LEDs; power consumption is reduced to $11\mu\text{A}$ (time averaged), including the current consumption of an external IR LED. An on-chip programmable interrupt function eliminates the need to continually poll the device for data, resulting in a significant power saving.

Ambient Light Sensing

The ambient light sensors are designed to detect brightness in the same way as human eyes do. To achieve this, the light sensor needs to have a spectral sensitivity that is identical to the photopic curve of the human eye (see Figure 1). Small deviations from the photopic curve can affect perceived brightness by ambient light sensors to be wildly different. However, there are practical difficulties in trying to reproduce the ideal photopic curve in a small cost-efficient package. The IC instead uses two different types of photodiodes (a green and an infrared) that have different spectral sensitivities—each of which is amplified and subtracted on-chip with suitable gain

coefficients so that the most extreme light sources (fluorescent and incandescent) are well matched to a commercial illuminance lux meter.

The photopic curve represents a typical human eye's sensitivity to wavelength. As can be seen in Figure 1 and Figure 2, its peak sensitivity is at 555nm (green). The human eye is insensitive to infrared ($> 700\text{nm}$) and ultraviolet ($< 400\text{nm}$) radiation.

Variation between light sources can extend beyond the visible spectral range. For example, fluorescent and incandescent light sources with similar visible brightness (lux) can have substantially different IR radiation content (since the human eye is blind to it). Since this infrared radiation can be picked up by silicon photodiodes, differences in light spectra can affect brightness measurement of light sensors. For example, light sources with high IR content, such as an incandescent bulb or sunlight, would suggest a much brighter environment than our eyes would perceive them to be. Other light sources such as fluorescent and LED-based systems have very little infrared content. The IC incorporates on-chip compensation techniques to minimize these effects and still output an accurate lux response in a variety of lighting conditions.

On-chip user-programmable green channel and IR channel gain trim registers allow the light sensor response to be tailored to the application, such as when the light sensor is placed under dark or colored glass.

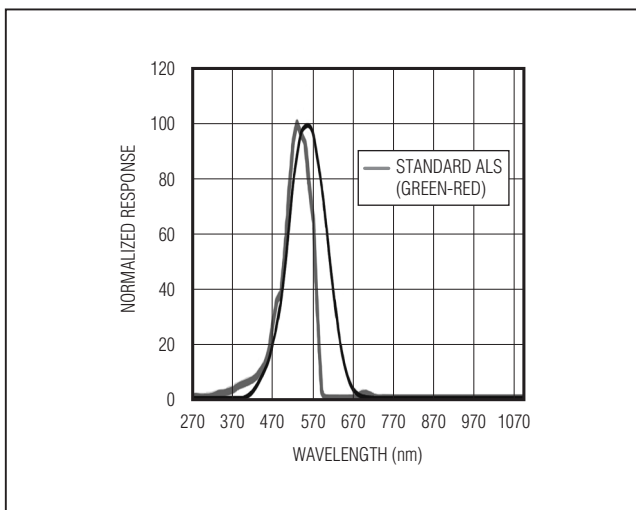

Figure 1. Spectral Response Compared to Ideal Photopic Curve

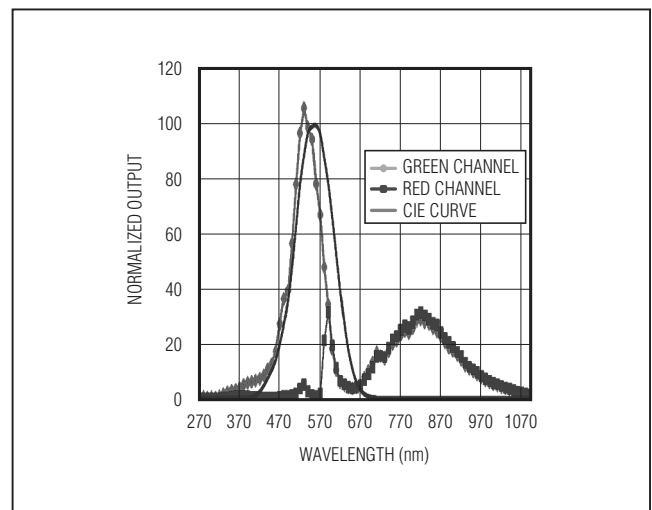

Figure 2. Green Channel and IR Channel Response at Identical Gains on a Typical MAX44000

Ambient and Infrared Proximity Sensor

Proximity Light Sensing

The proximity sensing uses an external, pulsed infrared LED source to emit controlled amounts of infrared radiation. When an external object reflects back some of this infrared radiation back to the IC, it is detected by the integrated light detector. The amount of reflected light detected is then used to determine the object's proximity to the sensor.

It is important to take account for the fact that different objects at the same distance from the sensor can reflect different amounts of infrared radiation depending on their texture and color.

The IC includes on-chip ambient cancellation circuitry in the receive path of the infrared proximity sensor. This scheme allows the part to operate in the presence of

large amounts of DC IR radiation. Due to the use of a single-pulse technique in pulsing the external infrared LED, the chip is also immune to fixed-frequency external infrared radiation such as from remote controls, electronic ballasts, etc., leading to more reliable infrared proximity sensor operation.

LED Driver

The IC features a LED driver that delivers a pulsed current at the output. The pulse amplitude is programmable through the I²C interface from 0 to 110mA in steps of 10mA. A low-voltage compliance of DRV pin allows IR LEDs to be powered from lower voltage rails, possibly even a 1.8V rail. High-current drive accuracy improves performance by eliminating part-to-part variation.

Register Description

REGISTER	B7	B6	B5	B4	B3	B2	B1	B0	REGISTER ADDRESS	POWER-ON RESET STATE	R/W
STATUS											
Interrupt Status						PWRON	PRXINTS	ALSINTS	0x00	0x04	R
CONFIGURATION											
Main Configuration			TRIM		MODE[2:0]		PRXINTE	ALSINTE	0x01	0x24	R/W
Receive Configuration	1	1	1	1	ALSTIM[1:0]		ALSPGA[1:0]		0x02	0x00	R/W
Transmit Configuration							DRV[3:0]		0x03	0x00	R/W
ADC DATA											
ADC High Byte (ALS)		OFL						ALSDATA[13:8]	0x04	0x00	R
ADC Low Byte (ALS)								ALSDATA[7:0]	0x05	0x00	R
ADC Byte (PROX)								PRXDATA[7:0]	0x16	0x00	R
THRESHOLD SET											
ALS Upper Threshold (High Byte)								UPTHR[13:8]	0x06	0x00	R/W
ALS Upper Threshold (Low Byte)								UPTHR[7:0]	0x07	0x00	R/W
ALS Lower Threshold (High Byte)								LOTHR[13:8]	0x08	0x00	R/W
ALS Lower Threshold (Low Byte)								LOTHR[7:0]	0x09	0x00	R/W

Ambient and Infrared Proximity Sensor

Register Description (continued)

REGISTER	B7	B6	B5	B4	B3	B2	B1	B0	REGISTER ADDRESS	POWER-ON RESET STATE	R/W
Threshold Persist Timer					PRXPST[1:0]		ALSPST[1:0]		0x0A	0x00	R/W
PROX Threshold Indicator		ABOVE							0x0B	0x00	R/W
PROX Threshold	PRXTHR[7:0]								0x0C	0x00	R/W
Digital Gain Trim of Green Channel	TRIM_GAIN_GREEN[6:0]							TRIM_GREEN_IR[0]	0x0F	0x80	R/W
Digital Gain Trim of Infrared Channel	TRIM_GAIN_IR[8:1]								0x10	0x80	R/W

The individual register bits are explained below. Default power-up bit states are highlighted in bold.

Interrupt Status Register (0x00)

REGISTER	B7	B6	B5	B4	B3	B2	B1	B0	REGISTER ADDRESS	POWER-ON RESET STATE	R/W
Interrupt Status						PWRON	PRXINTS	ALSINTS	0x00	0x04	R

The PWRON bit in the Interrupt Status register 0x00, if set, indicates that a power-on-reset (POR) condition has occurred, and any user-programmed thresholds cannot be valid anymore. The ALSINTS bit in the Interrupt Status register 0x00 indicates that an ambient light interrupt condition has occurred. The PRXINTS bit in the Interrupt Status register 0x00 indicates that a proximity receive interrupt condition has occurred. If any of these bits is set to 1, the $\overline{\text{INT}}$ pin is pulled low and asserted. **Note:** On Rev-1 of the device, the PWRON bit does not pull the $\overline{\text{INT}}$ pin low, even if set to 1.

Reading the Interrupt Status register clears the PWRON, ALSINTS, and PRXINTS bits, if set, and deasserts the $\overline{\text{INT}}$ pin. $\overline{\text{INT}}$ is pulled high by the off-chip pullup resistor. The ALSINTS and PRXINTS bits are disabled and set to 0 if the respective interrupt enable bits in Main Configuration register 0x01 are set to 0.

Ambient Interrupt Status (ALSINTS)

BIT 0	OPERATION
0	No interrupt trigger event has occurred.
1	The ambient light intensity has traversed outside the designated window limits defined by Threshold registers for greater than persist timer count ALSPST[1:0], or an overflow condition in the ambient light readings has occurred. This bit also causes the $\overline{\text{INT}}$ pin to be pulled low. Once set, the only way to clear this bit is to read this register or to set the ALSINTE bit in register 0x01 to 0.

Ambient and Infrared Proximity Sensor

MAX44000

Proximity Interrupt Status (PRXINTS)

BIT 1	OPERATION
0	No interrupt trigger event has occurred.
1	The IR proximity receive intensity has exceeded the threshold limit for greater than persist timer count PRXPST[1:0]. This bit also causes the $\overline{\text{INT}}$ pin to be pulled low. Once set, the only way to clear this bit is to read this register or to set PRXINTE bit to 0.

Power-On Reset Status (PWRON)

BIT 2	OPERATION
0	No interrupt trigger event has occurred.
1	The part went through a power-up event, either because the part was turned on or because there was a power-supply voltage glitch. All interrupt threshold settings in the registers have been reset to a default state and should be examined. A 1 on this bit also causes the $\overline{\text{INT}}$ pin to be pulled low. Note: $\overline{\text{INT}}$ is not pulled low on Rev-1 of the IC. Once this bit is set, the only way to clear this bit is to read this register.

Main Configuration Register (0x01)

REGISTER	B7	B6	B5	B4	B3	B2	B1	B0	REGISTER ADDRESS	POWER-ON RESET STATE	R/W
Main Configuration			TRIM	MODE[2:0]			PRXINTE	ALSINTE	0x01	0x24	R/W

This register is used to set the operating mode of the IC (ALS and/or proximity) and enable interrupt operation of the device.

TRIM

BIT 5	OPERATION
0	Use bytes written to TRIM_GAIN_GREEN[7:0] and TRIM_GAIN_IR[7:0] registers to set the fine-trim gain of the green and IR gain channels.
1	Use factory-programmed gains for green and IR channels. Ignore bytes written to TRIM_GAIN_GREEN[7:0] and TRIM_GAIN_IR[7:0] registers.

MODE[2:0]

The 3-bit MODE[2:0] defines eight operating modes for the IC, as shown below.

MODE[2:0]	OPERATING MODE	OPERATION
000	Shutdown	Analog circuits are shut down, but the digital register retains values.
001	ALS G-IR	Standard ALS mode stores the difference between green and infrared channel readings. Proximity channel operation and updates are disabled.
010	ALS G	ALS green channel only. Proximity channel operation and updates are disabled.
011	ALS IR	Infrared channel only. Proximity channel operation and updates are disabled.
100	ALS/PROX	ALS and PROX are interleaved continuously.
101	PROX Only	PROX only continuously. ALS channel operation and updates are disabled.
110	Reserved	Do not use.
111	Reserved	Do not use.

Ambient and Infrared Proximity Sensor

Proximity Interrupt Enable (PRXINTE)

BIT 1	OPERATION
0	The PRXINTS bit remains unasserted, and proximity channel readings are not compared with interrupt thresholds.
1	Detection of a proximity interrupt event triggers a hardware interrupt ($\overline{\text{INT}}$ pin is pulled low) and sets the PRXINTS bit (register 0x00, B1). Proximity channel readings are compared with proximity interrupt threshold settings and proximity persist timer.

Ambient Interrupt Enable (ALSINTE)

BIT 0	OPERATION
0	The ALSINTS bit remains unasserted, and ALS channel readings are not compared with interrupt thresholds.
1	Detection of an ambient light interrupt event triggers a hardware interrupt ($\overline{\text{INT}}$ pin is pulled low) and sets the ALSINTS bit (register 0x00, B0). ALS channel readings are compared with ALS interrupt threshold settings and ALS persist timer.

Receive Configuration Register (0x02)

REGISTER	B7	B6	B5	B4	B3	B2	B1	B0	REGISTER ADDRESS	POWER-ON RESET STATE	R/W
Receive Configuration	1	1	1	1	ALSTIM[1:0]		ALSPGA[1:0]		0x02	0x00	R/W

This register sets the ADC integration time and front-end photodiode circuitry sensitivity (gain) for the ALS channel. The ADC integration time also controls the bit resolution of measurements. ADC conversions are made of MSB first (the IC needs longer conversion times for higher resolution measurements). Use of lower PGA gains helps expand the full-scale range of the ADC at the expense of per-LSB sensitivity.

Ambient and Infrared Proximity Sensor

Ambient ADC Conversion Time (ALSTIM)

The 2-bit ALSTIM[1:0] sets the integration time for ALS ADC conversion, as shown in Table 1.

Table 1. Ambient ADC Conversion Time

ALSTIM[1:0]	INTEGRATION TIME (ms)	FULL-SCALE ADC COUNTS	BIT RESOLUTION	RELATIVE LSB SIZE
00	100	16,384	14	1x
01	25	4096	12	4x
10	6.25	1024	10	16x
11	1.5625	256	8	64x

Ambient Light Measurement Gain (ALSPGA)

The 2-bit ALSPGA[1:0] sets the gain of the ambient light sensing measurement according to Table 2.

Table 2. Ambient Light Measurement Gain

ALSPGA[1:0]	LUX/LSB	RELATIVE LSB SIZE
00	0.03125	1x
01	0.125	4x
10	0.5	16x
11	4	128x

Transmit Configuration Register (0x03)

This register controls the driver current setting and is used when the Proximity channel is enabled.

REGISTER	B7	B6	B5	B4	B3	B2	B1	B0	REGISTER ADDRESS	POWER-ON RESET STATE	R/W
Transmit Configuration					DRV[3:0]				0x03	0x00	R/W

LED Drive Current Setting (DRV)

The 4 bits of DRV set the LED drive current according to Table 3.

Table 3. LED Drive Current Settings

DRV[3:0]	LED CURRENT (mA)	DRV[3:0]	LED CURRENT (mA)
0000	LED driver disabled	1000	40
0001	10	1001	50
0010	20	1010	60
0011	30	1011	70
0100	40	1100	80
0101	50	1101	90
0110	60	1110	100
0111	70	1111	110

Ambient and Infrared Proximity Sensor

ALS Data Register (0x04, 0x05)

REGISTER	B7	B6	B5	B4	B3	B2	B1	B0	REGISTER ADDRESS	POWER-ON RESET STATE	R/W
ADC High Byte (ALS)		OFL	ALSDATA[13:8]						0x04	0x00	R
ADC Low Byte (ALS)	ALSDATA[7:0]						0x05	0x00	R		

The 2 bytes here (ALSDATA[13:0]) hold the results of the ALS signal conversion. The resolution and bit length of the result is controlled by the value of ALSTIM[1:0] and ALSPGA[1:0] bits. The result is always right justified in the two registers, and the unused high bits are zero.

OFL indicates an overflow condition on the ALS channel. If this occurs, set the ALS range (ALSPGA[1:0]) to a higher range. If the OFL bit is set to 1 (there is an overflow condition), and the ALSINTE bit is set to 1 (enabled), then the ALSINTS bit is set to 1 and the INT pin is pulled low.

The data in this register could be the green channel, infrared channel, or ALS readings (green channel, infrared channel readings), depending on the mode selected by the user.

Internal update of these two registers is disabled during I²C read operations to ensure proper data handoff between the ADC and the I²C registers. Update of the I²C registers is resumed once the master sends a STOP (P) command. Therefore, when reading the 2 bytes of this register, the master should not send a STOP command between the 2-byte reads. Instead, a Repeated START (Sr) command should be used. The exact read sequence using the Repeated START command is shown in the *I²C Serial Interface* section.

PROX Data Registers (0x15, 0x16)

REGISTER	B7	B6	B5	B4	B3	B2	B1	B0	REGISTER ADDRESS	POWER-ON RESET STATE	R/W
ADC Byte (PROX)	PRXDATA[7:0]							0x16	0x00	R	

The byte here (PRXDATA[7:0]) hold the results of the proximity receive signal conversion. Internal update of the register is disabled during I²C read operations to ensure proper data handoff between the ADC and the I²C registers. Update of the I²C registers is resumed once the master sends a STOP command.

Ambient and Infrared Proximity Sensor

MAX44000

ALS Interrupt Threshold Registers (0x06–0x09)

REGISTER	B7	B6	B5	B4	B3	B2	B1	B0	REGISTER ADDRESS	POWER-ON RESET STATE	R/W
ALS Upper Threshold (High Byte)			UPTHR[13:8]						0x06	0x00	R/W
ALS Upper Threshold (Low Byte)	UPTHR[7:0]								0x07	0x00	R/W
ALS Lower Threshold (High Byte)			LOTHR[13:8]						0x08	0x00	R/W
ALS Lower Threshold (Low Byte)	LOTHR[7:0]								0x09	0x00	R/W

The ALS upper threshold and ALS lower threshold (UPTHR[13:0] and LOTHR[13:0]) set the window limits that are used to trigger an ALS interrupt. It is important to set these values according to the selected bit resolution/integration time chosen for the ALS measurement based on the ALSTIM[1:0] and ALSPGA[1:0] settings. The upper 2 bits are always ignored. If the INTE bit is set, and the lux level is greater or lower than the respective thresholds for a period greater than that defined by the ALSPST persist time, the INTS bit in the Status register is set and the $\overline{\text{INT}}$ pin is pulled low.

ALS/PROX Threshold Persist Timer Register (0x0A)

REGISTER	B7	B6	B5	B4	B3	B2	B1	B0	REGISTER ADDRESS	POWER-ON RESET STATE	R/W
Threshold Persist Timer					PRXPST[1:0]		ALSPST[1:0]		0x0A	0x00	R/W

The MAX44000 incorporates a persist function that allows the users to set the number of consecutive triggers before interrupt. PRXPST[1:0] and ALSPST[1:0] set one of four persist values that control how readily the interrupt logic reacts to a detected event. This feature is added to reduce false or nuisance interrupts.

PRXPST[1:0] OR ALSPST[1:0]	NO. OF CONSECUTIVE TRIGGERS BEFORE INTERRUPT
00	1
01	2
10	4
11	16

When ALSPST[1:0] is set to 00, and the ALSINTE bit is set to 1, the first time an ALS interrupt event is detected, the ALSINTE interrupt bit is set and the $\overline{\text{INT}}$ pin goes low. If ALSPST[1:0] is set to 01, then four consecutive interrupt events must be detected on four consecutive measurement cycles. Similarly, if ALSPST[1:0] is set to 10, or 11, then 8 or 16 consecutive interrupts must be detected. If there is an intervening measurement cycle where no interrupt is detected, then the count is reset to zero. The proximity interrupt function is managed in the same way with PRXPST[1:0].

Ambient and Infrared Proximity Sensor

Proximity Threshold Registers (0x0B, 0x0C)

REGISTER	B7	B6	B5	B4	B3	B2	B1	B0	REGISTER ADDRESS	POWER-ON RESET STATE	R/W	
PROX Threshold Indicator		ABOVE								0x0B	0x00	R/W
PROX Threshold	PRXTHR[7:0]								0x0C	0x00	R/W	

The value set by PRXTHR[7:0] in combination with the ABOVE bit controls the operation of the proximity interrupt function. If the ABOVE bit is set to 1, the proximity interrupt has been enabled (PRXINTE = 1), and the result of a proximity measurement is greater than the value stored in PRXTHR[7:0], then a proximity interrupt event is recorded. The interrupt bit is set subject to count conditions set by PRXPST[1:0]. Similarly, if the ABOVE bit is set to 0, then an interrupt event is recorded if the result of a proximity measurement is less than value stored in PRXTHR[7:0].

Digital Gain Trim Registers (0x0F, 0x10)

REGISTER	B7	B6	B5	B4	B3	B2	B1	B0	REGISTER ADDRESS	POWER-ON RESET STATE	R/W	
Digital Gain Trim of Green Channel	TRIM_GAIN_GREEN[6:0]								TRIM_GAIN_IR[0]	0x0F	0x80	R/TW
Digital Gain Trim of Infrared Channel	TRIM_GAIN_IR[8:1]									0x10	0x80	R/TW

Note: Values read from TRIM_GAIN_ registers are the complements of the written value. This is true for reading both the factory-programmed values and the customer-programmed values.

TRIM_GAIN_GREEN[6:0] is used to modify the gain of the green channel.

TRIM_GAIN_IR[8:0] is used to modify the gain of the IR channel.

To tell the part to use the values written to this register, set the TRIM bit to 0 in the Main Configuration register after writing new values to these registers.

Ambient and Infrared Proximity Sensor

Applications Information

Ambient Sensing Applications

Typical applications involve placing the IC behind a glass with a small semitransparent window placed above it. Use the photodiode sensitive area as shown in Figure 3 to properly position the window above the part.

The part comes equipped with internal gain trim registers for the green and IR ALS photodiodes. By suitably choosing the gains for these channels, accurate ambient light readings can be generated in all lighting conditions irrespective of the type of glass the part is used under. This is especially useful for black-glass applications, where for cosmetic reasons, the part is placed behind a black film to hide its presence, and this film has the peculiar property of attenuating most ambient light, but passing through infrared radiation.

In standard ALS mode, the green channel and infrared channel readings are internally subtracted. Since one is observing only the difference in two separate ADC measurements, wrong readings can be obtained if one of the channels becomes saturated, while the other channel continues to rise. Since both the green photodiode also picks up a lot of the infrared signal, this saturation can occur much before the maximum expected full-scale range in certain lighting conditions. For example, under incandescent light, there is a lot more infrared optical power than in the visible spectral range. In these situations, the green channel can saturate much earlier than 511 lux in the most sensitive range. To assist the user in detecting these conditions, an OFL bit is provided that alerts the user of an overrange condition. This bit also triggers an ALS interrupt if it has been enabled.

Proximity Sensing Applications

The IC integrates a novel proximity sensor interface circuit with a robust built-in ambient IR cancellation scheme. The internal DC IR rejection circuit eliminates problems of ADC saturation in the presence of strong ambient infrared radiation, such as bright sunlight. Further, the proximity sensor uses a single-pulse scheme for the IR transmitter that eliminates red-glow problems seen in competing solutions to drive 850nm IR LEDs, while also reducing average IR LED power consumption to less than 0.1% of the IR LED peak current.

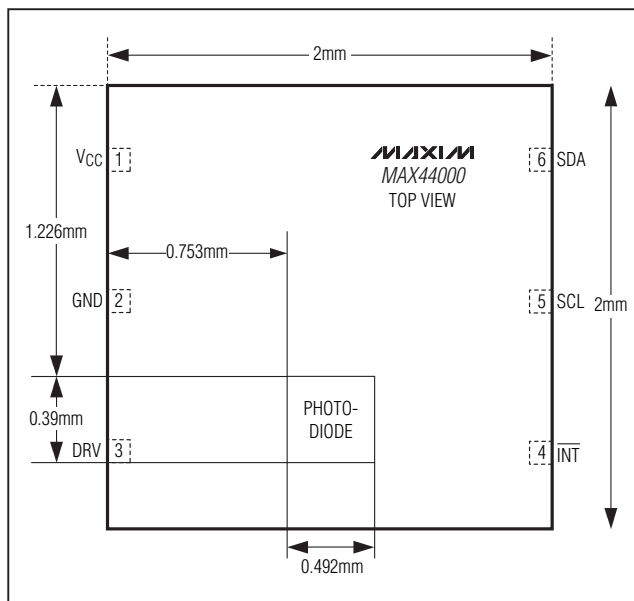

Interrupt Operation

Ambient interrupt is enabled by setting bit 0 of register 0x01 to 1 and proximity interrupt is enabled by setting bit 1 of register 0x01 to 1 (see Table 1 and Table 2). The interrupt pin, $\overline{\text{INT}}$, is an open-drain output and pulls low when an interrupt condition occurs (e.g., when ambient lux readings exceed threshold limits for a period greater than that set by the Time register). The interrupt status bit is cleared automatically if register 0x00 is read or if the interrupts are disabled.

A PWRON interrupt bit is set to alert the master of a chip reset operation in case of a power-supply glitch that can happen on smartphones that place the light sensor on a flex with a small connector.

It is best to utilize the interrupt pin on the IC to alert the master to come and read measurements from the IC. This eliminates the need for the microcontroller (I²C master) to continually poll the device for information. Due to the use of pullup resistors on the I²C bus, minimizing I²C bus activity can reduce power consumption substantially. In addition, this frees up the microcontroller resources to service other background processes to improve device performance. The wide variety of smarts available on the chip, such as the ability to set the threshold levels and to count persist timer limits, allow the part to operate in an autonomous mode most of the time.

MAX44000

Ambient and Infrared Proximity Sensor

Interrupt Pin Voltage Compliance

The interrupt pin can withstand external voltages up to 4V when in high-impedance mode per the absolute maximum ratings of the IC. However, when the voltage on the $\overline{\text{INT}}$ pin is higher than the V_{DD} of the part (such as when external pullup voltage is greater than V_{DD} of part), there is a small leakage current of 25 μA sink into $\overline{\text{INT}}$. This additional current drawn through the $\overline{\text{INT}}$ pin should also be accounted for in power-sensitive applications.

Typical Operating Sequence

The typical operating sequence for the master to communicate to the IC is shown below:

- 1) Read the Interrupt Status register (0x00) to confirm only the PWRON bit is set. This also clears a hardware interrupt. **Note:** For Rev-1 devices, a PWRON interrupt does not trigger a hardware interrupt.
- 2) Set the Threshold and Threshold Persist Timer registers for ambient and proximity sensor measurements (Registers 0x06–0x0C). **Note:** For Rev-1 devices, leave the Threshold Persist Timer register (Register 0x0A) set to 0.
- 3) Write F0 to the Receive Configuration register (Register 0x02) to set the ALS sensor in the highest gain setting and ALS ADCs in 14-bit modes of operation.
- 4) Set the IR LED current to a suitable level by writing to the Transmit Configuration register (0x03).
- 5) Write 0x13 to Main Configuration register (register 0x01) to set the part in ALS + proximity mode, and to enable ALS and proximity interrupts.
- 6) Set the new green channel gains and infrared channel gains, if necessary, to customize ALS operation for application conditions. Ensure the TRIM bit is set to 0 when not using default factory-trim settings.
- 7) Wait for interrupt.
- 8) Read the Interrupt Status register (0x00) to confirm the IC to be the source of interrupt, and to check for the type of interrupt. If set, this should clear the hardware interrupt on the part.
- 9) If an ALS interrupt has occurred, read the ADC High Byte (ALS) and ADC Low Byte (ALS) registers (registers 0x04, 0x05) to confirm if data is valid (i.e., OFL = 0), and take appropriate action (e.g., sets new backlight strength). Set new ALS thresholds, if necessary.
- 10) If a PROX interrupt has occurred, read the PROX ADC registers (register 0x15) and take appropriate action (typically, turn off or turn on touch screen and backlight). Set new proximity thresholds, if necessary.
- 11) Return to step 7.

I²C Serial Interface

The IC features an I²C/SMBus-compatible, 2-wire serial interface consisting of a serial-data line (SDA) and a serial-clock line (SCL). SDA and SCL facilitate communication between the IC and the master at clock rates up to 400kHz. Figure 4 shows the 2-wire interface timing diagram. The master generates SCL and initiates data transfer on the bus. A master device writes data to the IC by transmitting the proper slave address followed by the register address and then the data word. Each transmit sequence is framed by a START (S) or Repeated START condition and a STOP condition. Each word transmitted to the IC is 8 bits long and is followed by an acknowledge clock pulse. A master reading data from the IC transmits the proper slave address followed by a series of nine SCL pulses. The IC transmits data on SDA in sync with the master-generated SCL pulses. The master acknowledges receipt of each byte of data. Each read sequence is framed by a START or Repeated START condition, a not acknowledge, and a STOP condition. SDA operates as both an input and an open-drain output. A pullup resistor, typically greater than 500 Ω , is required on the SDA bus. SCL operates as only an input. A pullup resistor, typically greater than 500 Ω , is required on SCL if there are multiple masters on the bus, or if the master in a single-master system has an open-drain SCL output. Series resistors in line with SDA and SCL are optional. Series resistors protect the digital inputs of the IC from high-voltage spikes on the bus lines, and minimize crosstalk and undershoot of the bus signal.

Table 4. Slave Address

SLAVE ADDRESS FOR WRITING	SLAVE ADDRESS FOR READING
1001 0100	1001 0101

Ambient and Infrared Proximity Sensor

MAX44000

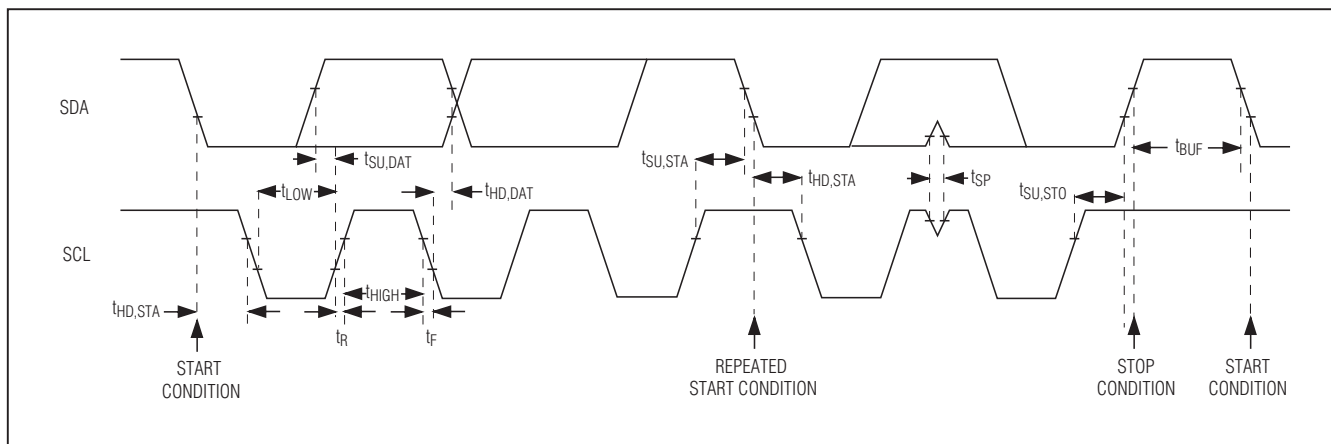

Figure 4. 2-Wire Interface Timing Diagram

Bit Transfer

One data bit is transferred during each SCL cycle. The data on SDA must remain stable during the high period of the SCL pulse. Changes in SDA while SCL is high are control signals. See the *START and STOP Conditions* section. SDA and SCL idle high when the I²C bus is not busy.

START and STOP Conditions

SDA and SCL idle high when the bus is not in use. A master initiates communication by issuing a START condition. A START condition is a high-to-low transition on SDA with SCL high. A STOP condition is a low-to-high transition on SDA while SCL is high (Figure 5). A START condition from the master signals the beginning of a transmission to the IC. The master terminates transmission, and frees the bus by issuing a STOP condition. The bus remains active if a Repeated START condition is generated instead of a STOP condition.

Early STOP Conditions

The IC recognizes a STOP condition at any point during data transmission except if the STOP condition occurs in

the same high pulse as a START condition. For proper operation, do not send a STOP condition during the same SCL high pulse as the START condition.

Acknowledge

The acknowledge bit (ACK) is a clocked 9th bit that the IC uses to handshake receipt of each byte of data when in write mode (Figure 6). The IC pulls down SDA during the entire master-generated ninth clock pulse if the previous byte is successfully received. Monitoring ACK allows for detection of unsuccessful data transfers. An unsuccessful data transfer occurs if a receiving device is busy or if a system fault has occurred. In the event of an unsuccessful data transfer, the bus master can retry communication. The master pulls down SDA during the ninth clock cycle to acknowledge receipt of data when the IC is in read mode. An acknowledge is sent by the master after each read byte to allow data transfer to continue. A not acknowledge is sent when the master reads the final byte of data from the IC, followed by a STOP condition.

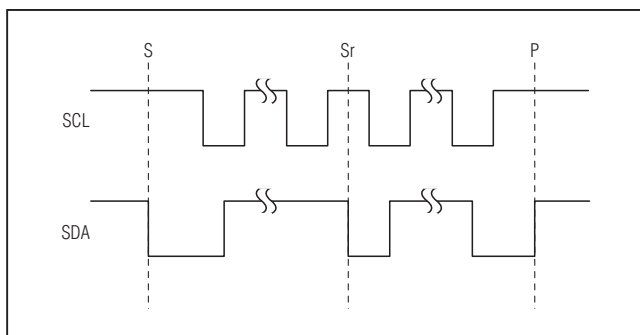

Figure 5. START, STOP, and Repeated START Conditions

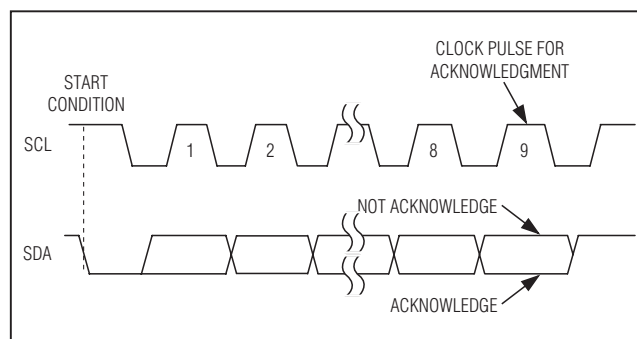

Figure 6. Acknowledge

Ambient and Infrared Proximity Sensor

Write Data Format

A write to the IC includes transmission of a START condition, the slave address with the R/\bar{W} bit set to 0, 1 byte of data to configure the internal register address pointer, one or more bytes of data, and a STOP condition. Figure 7 illustrates the proper frame format for writing 1 byte of data to the IC.

The slave address with the R/\bar{W} bit set to 0 indicates that the master intends to write data to the IC. The IC acknowledges receipt of the address byte during the master-generated ninth SCL pulse.

The second byte transmitted from the master configures the IC's internal register address pointer. The pointer tells the IC where to write the next byte of data. An acknowledge pulse is sent by the IC upon receipt of the address pointer data.

The third byte sent to the IC contains the data that is written to the chosen register. An acknowledge pulse from the IC signals receipt of the data byte. Figure 8 illustrates how to write to multiple registers with one frame. The master signals the end of transmission by issuing a STOP condition.

Read Data Format

Send the slave address with the R/\bar{W} bit set to 1 to initiate a read operation. The IC acknowledges receipt of its slave address by pulling SDA low during the ninth SCL clock pulse. A START command followed by a read command resets the address pointer to register 0x00.

The first byte transmitted from the IC is the contents of register 0x00. Transmitted data is valid on the rising edge of the master-generated serial clock (SCL). The address pointer autoincrements after each read data byte. This autoincrement feature allows all registers to be read sequentially within one continuous frame. A STOP condition can be issued after any number of read data bytes. If a STOP condition is issued followed by another read operation, the first data byte to be read is from register 0x00 and subsequent reads autoincrement the address pointer until the next STOP condition. The address pointer can be preset to a specific register before a read command is issued. The master presets the address pointer by first sending the IC's slave address with the R/\bar{W} bit set to 0 followed by the register address. A Repeated START condition is then sent, followed by the slave address with the R/\bar{W} bit set to 1. The IC transmits the contents of the specified register. The address pointer autoincrements after transmitting the first byte. Attempting to read from register addresses higher than 0xFF results in repeated reads of 0xFF. Note that 0xF6 to 0xFF are reserved registers. The master acknowledges receipt of each read byte during the acknowledge clock pulse. The master must acknowledge all correctly received bytes except the last byte. The final byte must be followed by a not acknowledge from the master and then a STOP condition. Figure 8 illustrates the frame format for reading 1 byte from the IC. Figure 9 illustrates the frame format for reading two registers consecutively without a STOP condition in between reads.

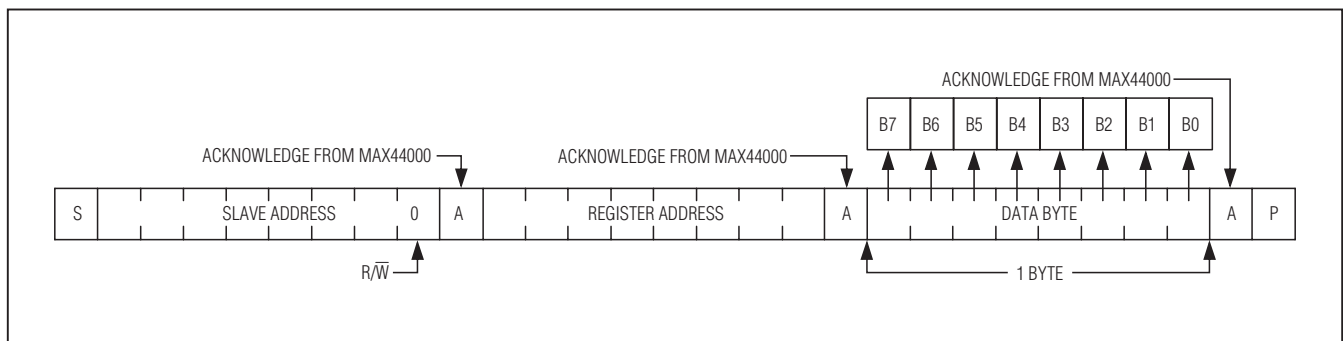

Figure 7. Writing 1 Byte of Data to the IC

Ambient and Infrared Proximity Sensor

MAX44000

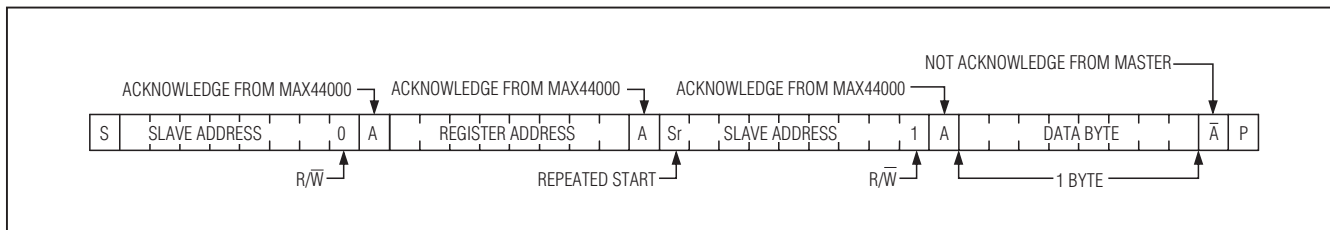

Figure 8. Reading 1 Indexed Byte of Data from the IC

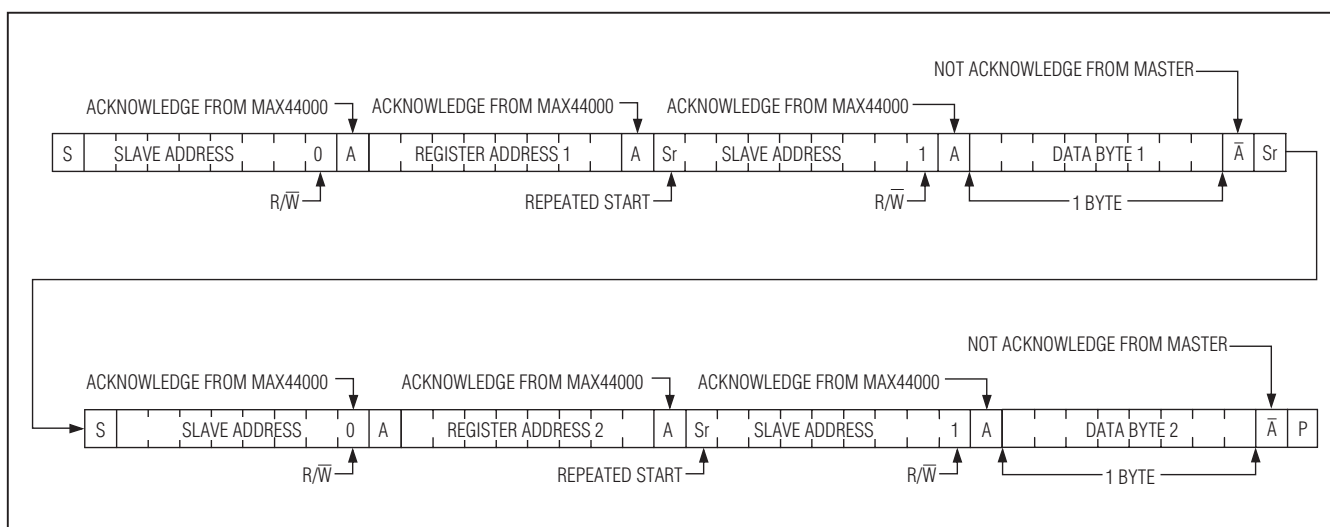
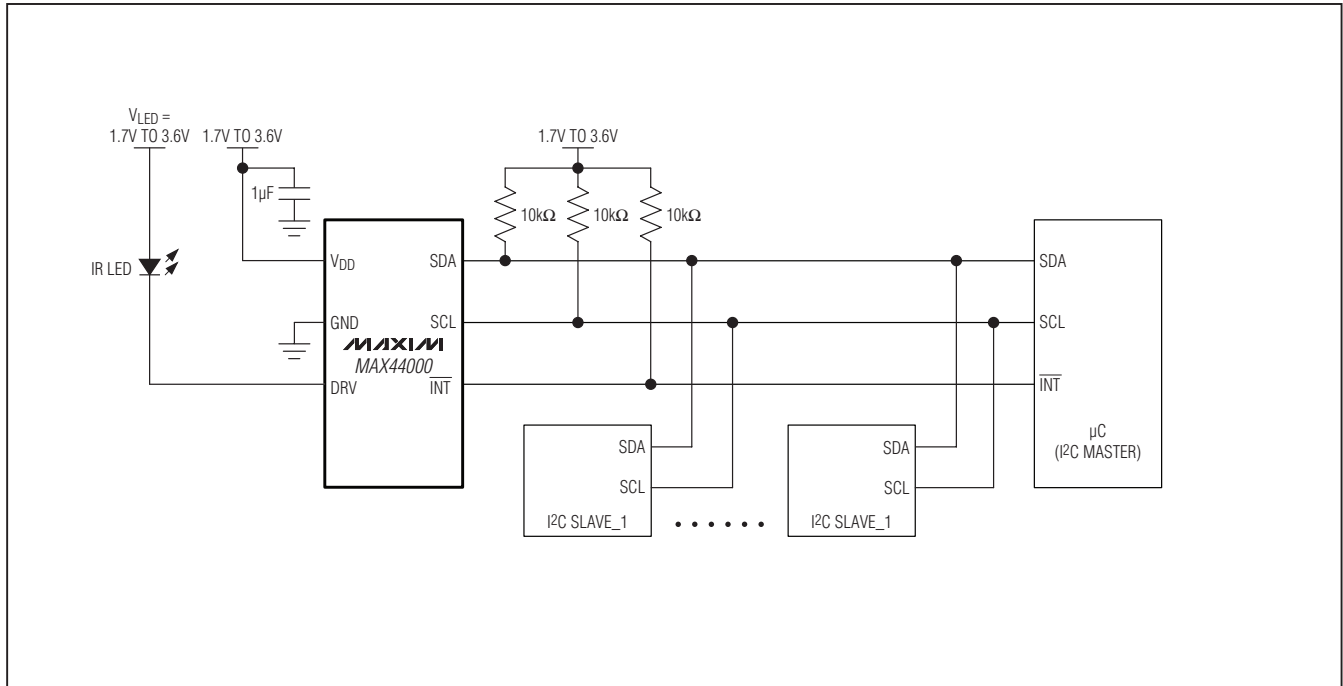

Figure 9. Reading Two Registers Consecutively Without a STOP Condition Between Reads

Ambient and Infrared Proximity Sensor

MAX44000

Typical Applications Circuit



Ambient and Infrared Proximity Sensor

MAX44000

Package Information

For the latest package outline information and land patterns (footprints), go to www.maxim-ic.com/packages. Note that a "+", "#", or "-" in the package code indicates RoHS status only. Package drawings may show a different suffix character, but the drawing pertains to the package regardless of RoHS status.

PACKAGE TYPE	PACKAGE CODE	OUTLINE NO.	LAND PATTERN NO.
6 OTDFN-EP	D622N+2	21-0490	90-0344

TOP VIEW

BOTTOM VIEW

SIDE VIEW

DIMENSION	COMMON DIMENSIONS		
	MIN.	NOM.	MAX.
A3	0.195	0.203	0.211
b	0.20	0.25	0.30
D	1.925	2.000	2.075
E	1.925	2.000	2.075
e	0.65 BSC		
L	0.25	0.30	0.35

DIMENSION	DIMENSION VARIATIONS		
	MIN.	NOM.	MAX.
A	0.55	0.60	0.65
E2	1.25	1.35	1.45
D2	0.55	0.65	0.75

NOTES:

1. DIMENSION & TOLERANCING CONFORM TO ASME Y14.5M-1994.
2. ALL DIMENSIONS ARE IN MILLIMETERS.
3. DIMENSION b APPLIES TO METALLIZED TERMINAL AND IS MEASURED BETWEEN 0.20mm AND 0.30mm FROM TERMINAL TIP.
4. MARKING SHOWN IS FOR PACKAGE ORIENTATION PURPOSE ONLY.
5. ALL DIMENSIONS APPLY TO PbFREE (+) PKGCODES ONLY.

—DRAWING NOT TO SCALE—

MAXIM			
TITLE: PACKAGE OUTLINE, 6L, 2x2 OPTO TDFN PKG. NiPd PLATING			
APPROVAL	DOCUMENT CONTROL NO. 21-0490	REV. C	1/1

Ambient and Infrared Proximity Sensor

Revision History

REVISION NUMBER	REVISION DATE	DESCRIPTION	PAGES CHANGED
0	10/11	Initial release	—

Maxim cannot assume responsibility for use of any circuitry other than circuitry entirely embodied in a Maxim product. No circuit patent licenses are implied. Maxim reserves the right to change the circuitry and specifications without notice at any time.

24 **Maxim Integrated Products, 120 San Gabriel Drive, Sunnyvale, CA 94086 408-737-7600**

© 2011 Maxim Integrated Products

Maxim is a registered trademark of Maxim Integrated Products, Inc.