

MAXIM

CMOS Video Amplifier

MAX450/451

General Description

The MAX450 video amplifier is designed to buffer and amplify signals from DC through 10MHz. This monolithic CMOS amplifier has a high impedance CMOS input, while the output can drive 75 ohm loads to greater than $\pm 2V$ output swing.

Optimized for $\pm 12V$ supplies, the MAX450 can operate with power supplies ranging from $\pm 10V$ to $\pm 15V$. The MAX450 needs no compensation for gains greater than 20, and provides 4 terminals for two simple RC compensation networks. The MAX450 is "well behaved" and is not prone to oscillations, and the MAX450 is relatively insensitive to variations in printed circuit board layout.

Its $100V/\mu s$ slew rate and the ability to drive 75Ω loads make the MAX450 ideally suited for systems which distribute video or other 10MHz bandwidth signals via 75Ω coaxial cables.

The MAX451 provides all of the features of the MAX450, plus a guaranteed $1nA$ maximum input bias current. This combination of low bias current and video bandwidth is well suited for vidicon preamps, for photodetector preamps in fiber optics systems up to a 10MHz bit rate, and other applications which demand low input bias current, 10MHz bandwidth, and high current output drive capability.

Applications

- Video Amplifiers
- PIN Photodiode Amplifiers
- Vidicon Amplifiers
- Pulse Amplifier
- High Input Impedance Video Buffers Amplifiers
- CCD Amplifier

Pin Configuration

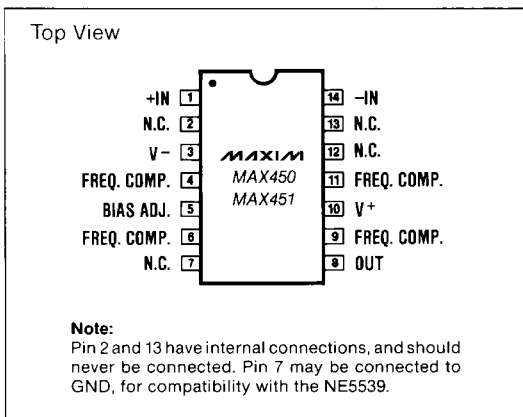

Features

- ◆ 10MHz Power Bandwidth
- ◆ $\pm 4.0V$ Output Swing into Back Terminated 75Ω Coax ($R_L = 150\Omega$)
- ◆ 0.1dB Differential Gain
- ◆ 0.1° Differential Phase
- ◆ 400pA (typical) Input Bias Currents
- ◆ $100V/\mu s$ Slew Rate
- ◆ 53dB Gain at 300kHz
- ◆ Output is Short Circuit Protected
- ◆ $5pA/\sqrt{Hz}$ Current Noise

Ordering Information

PART	TEMP. RANGE	PACKAGE
MAX450CPD	$0^\circ C$ to $+70^\circ C$	14 Lead Plastic DIP
MAX450CJD	$0^\circ C$ to $+70^\circ C$	14 Lead CERDIP
MAX450C/D	$0^\circ C$ to $+70^\circ C$	Dice
MAX451CPD	$0^\circ C$ to $+70^\circ C$	14 Lead Plastic DIP
MAX451CJD	$0^\circ C$ to $+70^\circ C$	14 Lead CERDIP
MAX451C/D	$0^\circ C$ to $-70^\circ C$	Dice

Typical Operating Circuit

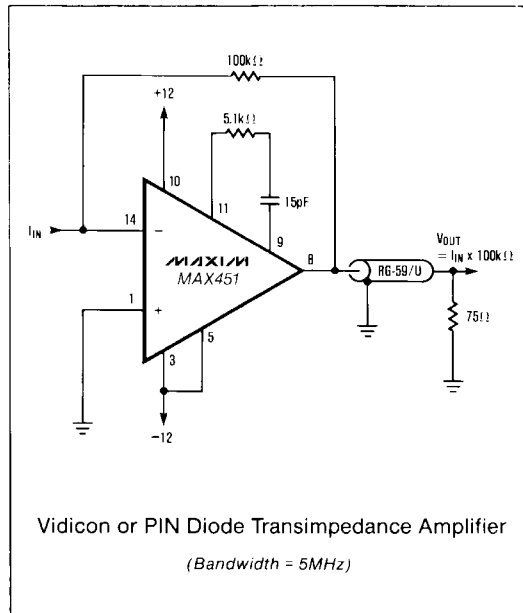

MAXIM

Maxim Integrated Products 1

MAXIM is a registered trademark of Maxim Integrated Products.

CMOS Video Amplifier

ABSOLUTE MAXIMUM RATINGS

V ⁺ - V ⁻ , pin 3 connected to pin 5	+26.4V	Power Dissipation at +25°C	
V ⁺ - V ⁻ , 1kΩ between pin 3 and pin 5	+36V	Plastic Package	1250mW
+IN, -IN	(V ⁺ + 0.3V) to (V ⁻ - 0.3V)	(derate 10mW/°C above 25°C)	
Short Circuit Duration, V _{OUT}	Continuous with V ⁺ , V ⁻ = ±12V	CERDIP Package	1190mW
		(derate 9.5mW/°C above 25°C)	
		Storage Temperature	-65°C to +160°C

Stresses above those listed under "Absolute Maximum Ratings" may cause permanent damage to the device. These are stress ratings only and functional operation of the device at these or any other conditions above those indicated in the operational sections of the specifications is not implied. Exposure to absolute maximum rating conditions for extended periods may affect device reliability.

ELECTRICAL CHARACTERISTICS

(V_{SUPP} = ±12V, T_A = +25°C)

PARAMETER	SYMBOL	CONDITIONS	MAX450			MAX451			UNITS
			MIN	TYP	MAX	MIN	TYP	MAX	
Input Offset Voltage	V _{OS}	V _{OUT} = 0V, R _S = 100Ω	-30	8	30	-30	8	30	mV
Input Bias Current	I _{BIAS}	V _{IN} = 0		0.4		0.4	1		nA
Common Mode Voltage Range	V _{CMR}			±6		±6			V
Output Voltage Swing	V _{OUT}	f = 1MHz, R _L = 150Ω (Note 1)	±3	±4		±3	±4		V
		f = 1MHz, R _L = 75Ω (Note 1)	±2	±3.5		±2	±3.5		
Large Signal Voltage Gain	A _{VOL}	f = 1MHz, R _L = 150Ω		200		200			V/V
Unity Gain Bandwidth	G _{BW}	V _{OUT} = 1V _{p-p} , R _L = 150Ω		10		10			MHz
Input Capacitance	C _{IN}	Plastic		3		3			pF
		CERDIP		6		6			pF
Input Resistance	R _{IN}	DC to 100kHz		10 ⁷		10 ⁷			Ω
		f = 1MHz		10 ⁶		10 ⁶			
Output Resistance	R _{OUT}	f = 1MHz		5		5			Ω
Common Mode Rej. Ratio	CMRR	V _{CM} = ±1.7, R _S = 100Ω	50	55		50	55		dB
Power Supply Rejection Ratio	PSRR	ΔV _{CC} = ±1V		40		40			mV/V
Supply Current	I _{SUPP}	V _{IN} = 0V		25	35		25	35	mA
Slew Rate	SR	A _V = +1, R _L = 150Ω		100		100			V/μs

Note 1: Guaranteed by design; not production tested.

Typical Operating Characteristics

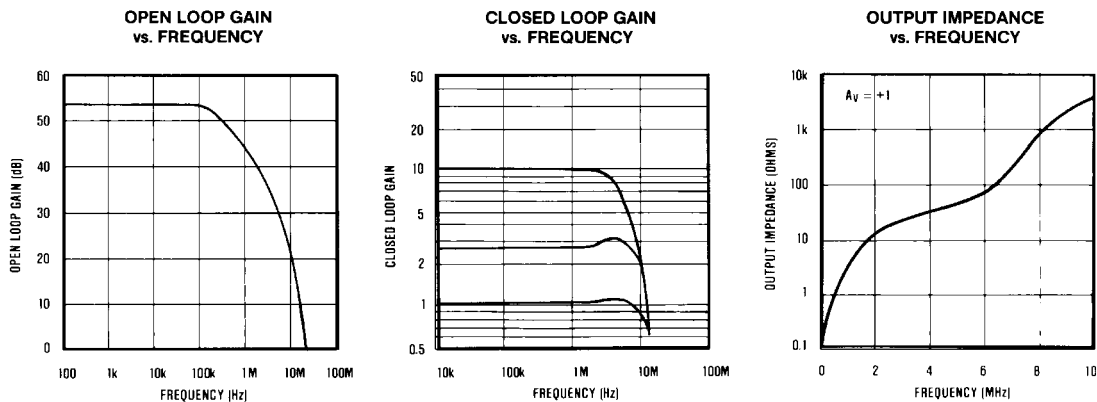

CMOS Video Amplifier

MAX450/451

Detailed Description

Compensation, Layout and Bypassing

Figures 1 and 2 show typical applications, including the proper compensation network. Specific compensation component values for different closed loop gains are given in Table 1. For gains above 20, the MAX450/451 does not require any compensation. The easiest way to test for proper compensation is to drive the input with a low amplitude square wave and observe the overshoot. Less than 20% overshoot is normally considered acceptable. The RC network connected between pins 4 and 6 control the negative slew rate, while the RC network connected between pins 9 and 11 control the positive slew rate.

The MAX450/451, unlike many other video amplifiers, is relatively insensitive to printed circuit board layout. $+V_{CC}$ and $-V_{CC}$ should be bypassed to ground with a $0.1\mu\text{F}$ or $1\mu\text{F}$ ceramic bypass capacitor. A ground plane should be used to minimize the inductance of the ground connection, and in particular to minimize any ground return inductance that is included in both the input and output return paths.

Power Dissipation and Output Swing

The MAX450/451 operates as a class AB amplifier with the output stage quiescent current being all but 5mA of the total quiescent current. In order to operate in a class A mode for up to $\pm 15\text{mA}$ output current,

the MAX450/451 quiescent current is set to approximately 25mA with $\pm 12\text{V}$ supplies and the Bias Adjustment pin connected directly to $-V_{CC}$. This sets the typical power dissipation to 600mW. When output current is drawn, it diverts current from the output stage and actually reduces power dissipation.

For output voltage swings less than $\pm 8\text{V}$, the output voltage swing is directly proportional to the load resistance, since the MAX450/451 output current capability is nearly independent of the output voltage swing below $\pm 8\text{V}$. The source follower configuration of the MAX450 output stage limits the no load output voltage to $+V_{CC} - 4\text{V}$.

If operation is desired over the full temperature range, the quiescent current must be reduced by connecting a resistor between $-V_{CC}$ and the Bias Adjustment pin. While reducing the quiescent current, this also creates an output offset as shown in the typical characteristics graphs. Adding a bias adjustment resistor will also reduce the DC output current capability, but the full $\pm 30\text{mA}$ AC output current capability can be maintained by bypassing the bias adjustment resistor with a $0.1\mu\text{F}$ to $1.0\mu\text{F}$ ceramic capacitor. The effect of the bias resistor is shown in Table 2.

Warmup Effects and High Speed Automatic Testing

The MAX450/451 has a typical power dissipation of 600mW. During high speed automatic testing the package temperature has not stabilized and the die temperature is lower than will be observed in actual operation. The parameters most significantly affected by this heating effect are supply current and input bias current. Maxim measures the input bias current after approximately 2 seconds, using test limits chosen such that the data sheet specification limits will not be exceeded, even after the device has been on for several minutes and has achieved thermal equilibrium.

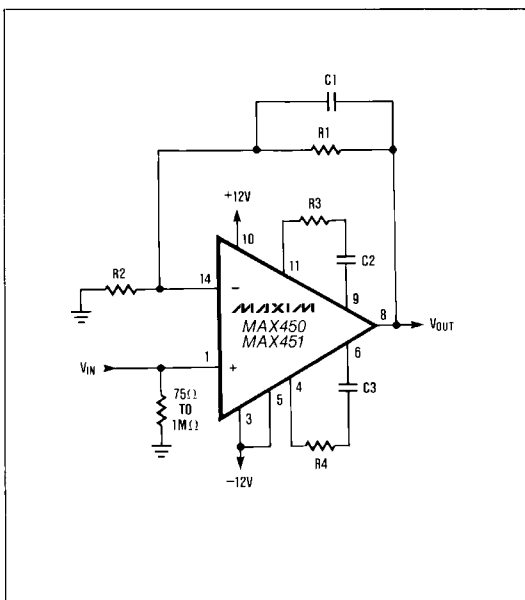

Figure 1. Non-inverting Configuration.

Table 1: Component Values for Figure 1

COMPONENT	GAIN			
	+1	+2.5	+4	+10
R1	0 Ω	1.5k Ω	3k Ω	3k Ω
R2	None	1k Ω	1k Ω	330 Ω
R3	2.2k Ω	4.7k Ω	4.7k Ω	5.1k Ω
R4	1.5 Ω	1.5k Ω	5.1k Ω	None
C1	None	3pF	3pF	3pF
C2	10pF	5pF	5pF	3pF
C3	10pF	10pF	3pF	None

CMOS Video Amplifier

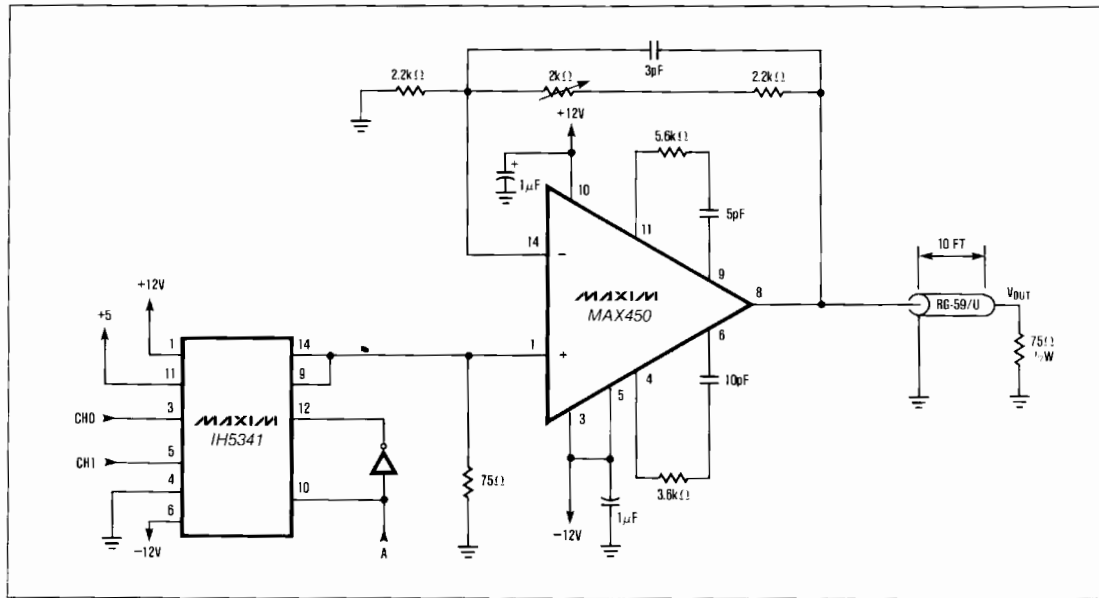

Figure 2. 2 Channel Lossless Video Switch.

Table 2: Effect of Bias Resistor (bypassed with 1μF ceramic capacitor)

R _{BIAS} (Ω) BETWEEN PINS 3 AND 5	I _O (mA) V _{CC} = ±12V	V _{OS} (mV)	OUTPUT SWING (V) 1kHz into 75Ω	OUTPUT SWING (V) 1MHz into 75Ω	SLEW RATE (V/μs)	BANDWIDTH (MHz) GAIN = +2
0	25	±10	+4.8, -4.2	±3.5V	+100, -67	10
330	21	+20	+4.8, -4.0	±3.0V	-100, -40	9.5
500	19	+25	+4.8, -3.7	±2.9V	+100, -40	9.3
1k	15	+50	+4.7, -3.4	±2.8V	+100, -20	8.8

Package Information

14 Lead Plastic DIP (Copper)

$\theta_{JA} = 100^{\circ}\text{C/W}$
 $\theta_{JC} = 60^{\circ}\text{C/W}$

14 Lead CERDIP

$\theta_{JA} = 105^{\circ}\text{C/W}$
 $\theta_{JC} = 50^{\circ}\text{C/W}$

Chip Topography

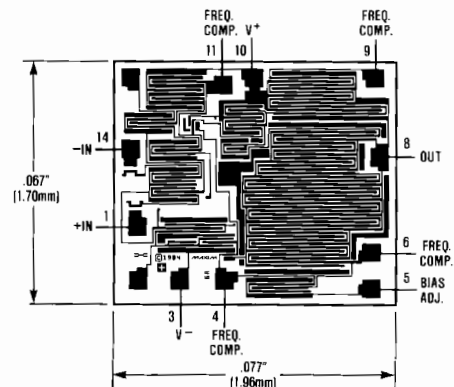

Maxim cannot assume responsibility for use of any circuitry other than circuitry entirely embodied in a Maxim product. No circuit patent licenses are implied. Maxim reserves the right to change the circuitry and specifications without notice at any time.