

THIS DRAWING IS UNPUBLISHED. RELEASED FOR PUBLICATION
 © COPYRIGHT 19 BY AMP INCORPORATED. ALL INTERNATIONAL RIGHTS RESERVED.

LOC	DIST	P	F	ZONE	LTR	REVISIONS	DATE	APPD
G	14				G	REV & REDRAWN PER 0720-0061-93	4-19-93	JL

METRIC
 DIMENSIONS LISTED IN mm [INCHES]

AMP WIRE RANGE	UL E13288 Listed
16-14 AWG SOLID OR STRANDED	NOT APPLICABLE
UL LR7189 Certified	MILITARY P/N AND CLASS
NOT APPLICABLE	NOT APPLICABLE

△ STAMP AMP 16-14* APPROX AS SHOWN

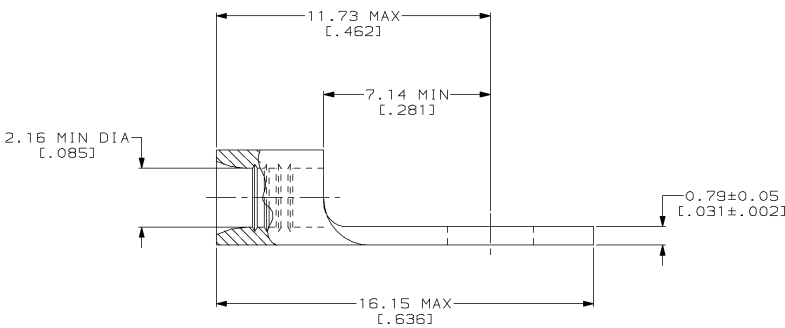
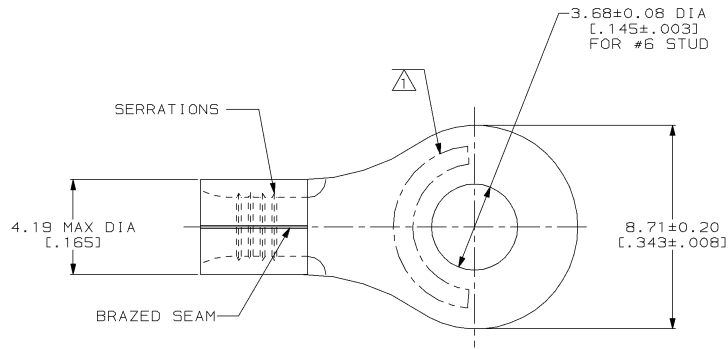

AMP INCORPORATED CUSTOMER SERVICE SYSTEMS		MAX RECOMMENDED OPERATING TEMPERATURE: 343°C MAX	DO NOT SCALE PRINT. UNLESS SPECIFIED DIMENSIONS IN mm (INCHES) TOLERANCES ON: 2 PLC DEC ± - 3 PLC DEC ± - ANGLES ± -	DR 4-19-93 TA BRINKMAN CHK 4-19-93 DA PATTERSON APPD 4-19-93 DE MILLER APPD 4-19-93 JL MECKLEY PRODUCT SPEC -	322693 PART NO
FOR ADDITIONAL PRODUCT INFORMATION OR COPIES OF DRAWINGS AND TECHNICAL DOCUMENTS	PRODUCT INFORMATION CENTER 1-800-522-6752	VOLTAGE RATING: NOT APPLICABLE	MATERIAL COPPER PER ASTM B-152 ANNEALED	NAME AMP AMP Incorporated Harrisburg, PA 17105-3608	TERMINAL, RING TONGUE, HEAT RESISTANT, STRATO-THERM™
FOR APPLICATION TOOLING INFORMATION	TOOLING ASSISTANCE CENTER 1-800-722-1111	WIRE CROSS SECTIONAL AREA RANGE: 1.04-2.62mm² [2,050-5,180] CIR MILS SOLID OR STRANDED	FINISH NICKEL PLATE 0.00762[.000300] MIN THK PER QQ-N-290	SIZE 00779 CAGE CODE	
FOR ORDER ENTRY	1-800-526-5142	THIS DRAWING IS A CONTROLLED DOCUMENT FOR AMP INCORPORATED. IT IS SUBJECT TO CHANGE AND THE CONTROLLING ENGINEERING ORGANIZATION SHOULD BE CONTACTED FOR THE LATEST REVISION.	APPLICATION SPEC -	DRAWING NO C-322693	SCALE 8:1
			WEIGHT -	SHEET 1 OF 1	CUSTOMER DRAWING