

DRAWING MADE IN THIRD ANGLE PROJECTION

THIS DRAWING IS A CONTROLLED DOCUMENT FOR AMP INCORPORATED. IT IS SUBJECT TO CHANGE AND THE CONTROLLING ENGINEERING ORGANIZATION SHOULD BE CONTACTED FOR THE LATEST REVISION.

LOC	DIST	REVISIONS			DATE	APPROVED	
		P	F	LTR			DESCRIPTION
G	14			D	REVISED & REDRAWN PER G-5803	6/12/92	DKS / AJK

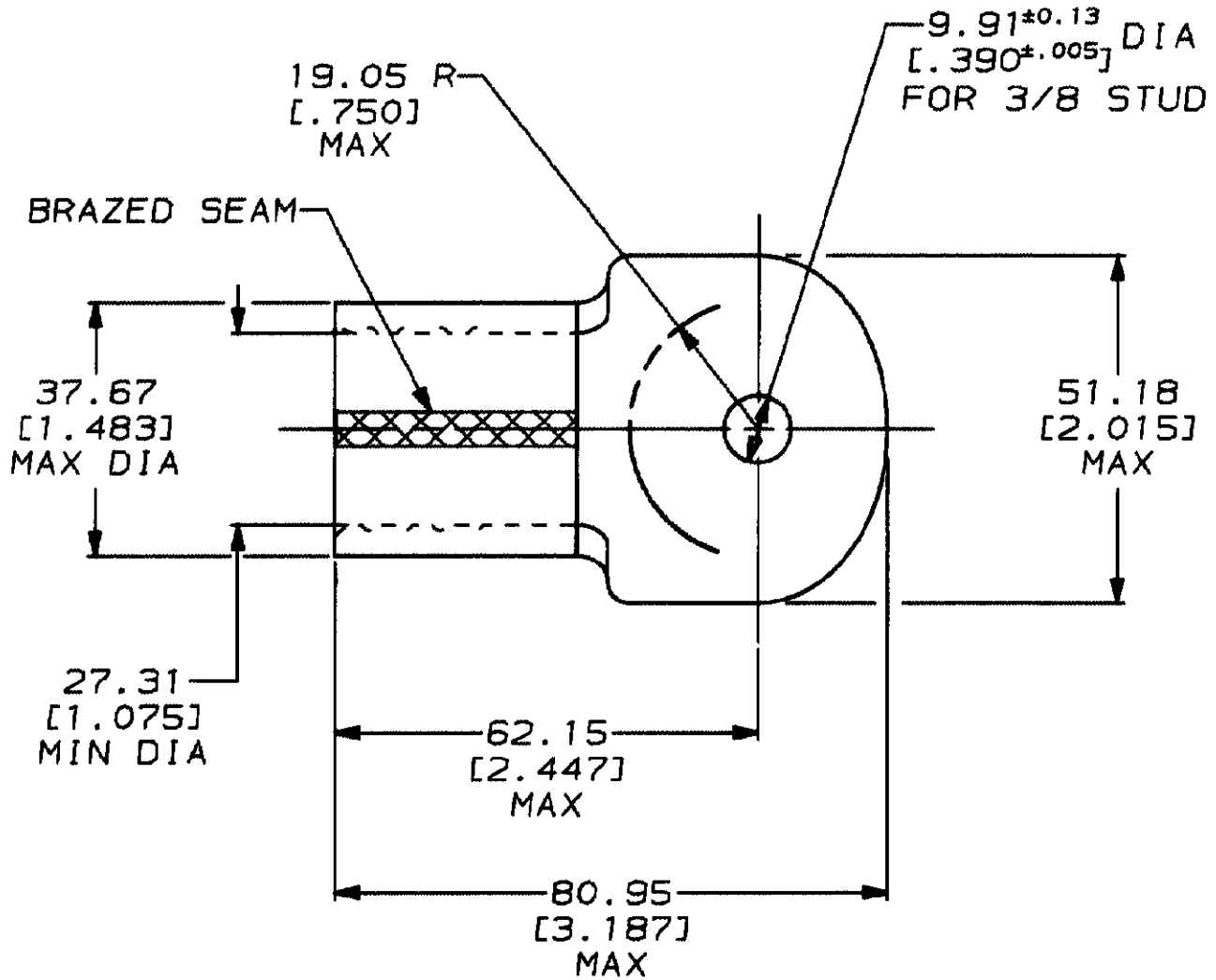

THIS DRAWING IS UNPUBLISHED. RELEASED FOR PUBLICATION BY AMP INCORPORATED. ALL INTERNATIONAL RIGHTS RESERVED. COPYRIGHT 19

322267
PART NO

DO NOT SCALE PRINT. UNLESS SPECIFIED DIMENSIONS IN mm [IN] TOLERANCES ON:
2 PLC DEC ± 0.20[.008]
3 PLC DEC * -
ANGLES * -

MATERIAL
COPPER ASTM B-152 ANNEALED

FINISH
TIN PLATE
0.00254[.000100] MIN THK PER MIL-T-10727

DR 6/12/92
DK SCHRUM

CHK 6/26/92
RD HEIM

APPD 6/26/92
AJ KAUFMAN

APPD 6/26/92
CR RHOADS

PRODUCT SPEC
-

APPLICATION SPEC
-

WEIGHT -

AMP AMP Incorporated
Harrisburg, PA 17105-3608

NAME
TERMINAL, RING TONGUE, SOLISTRAND™
WIRE SIZE: 253.0-304.0mm² [500-600] MCM

SIZE A	CAGE CODE 00779	DRAWING NO C-322267
SCALE 1:1	SHEET 1 OF 1	

AMP 1469-32 REV 3-92

12 JUN 1992 13:56:17 AMP26463 <U5128A>DEPT1123>DWG1123>U SOLISTRAND>U.MCM

CUSTOMER DRAWING