

THIS DRAWING IS UNPUBLISHED. RELEASED FOR PUBLICATION  
 © COPYRIGHT - By - ALL RIGHTS RESERVED.

LOC	DIST	REVISIONS					
G	14	P	LTR	DESCRIPTION	DATE	DWN	APVD
		R2		REVISED PER ECO-11-004917	11MAR11	RK	HMR

<b>AMP</b> WIRE RANGE	Listed FILE E13288	LR7189 Certified
22-16 AWG SOLID OR STRANDED	22-16 AWG SOLID OR STRANDED	22-16 AWG SOLID OR STRANDED

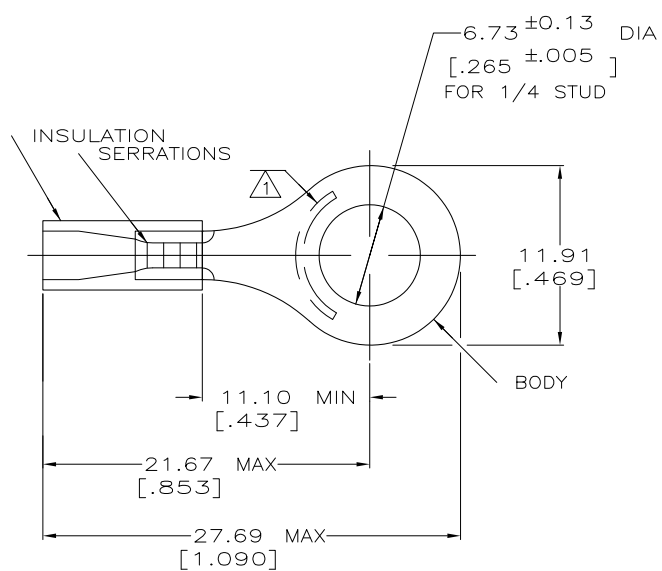

- 1 STAMP AMP 22-18\* APPROX AS SHOWN  
22-16 TERMINALS ARE STAMPED 22-18 IN  
ACCORDANCE WITH MILITARY SPEC MIL-T-7928  
COMMERCIAL WIRE RANGE IS 22-16
- 2 WIRE INSULATION DIA: 2.67-3.56 [0.105-0.140]
- 3 TONGUE MATERIAL THK: 0.79±0.05 [0.031±0.002]
- 4 MATERIAL: BODY - CU PER ASTM B152  
SLEEVE - PVC, COLOR - RED
- 5 MATERIAL: BODY - CU PER ASTM B152  
SLEEVE - PVC, COLOR - BLACK

OBsolete	QTY	PACKAGE TYPE	PART NO.
25	LOOSE PC,BAG	4	8-34150-5
100	LOOSE PC,BOX	4	8-34150-1
5000	ON TAPE, REEL	5	2-34150-3
5000	ON TAPE, REEL	4	2-34150-1
1000	LOOSE PIECE	4	34150

AMP INCORPORATED CUSTOMER SERVICE SYSTEMS		MAX RECOMMENDED OPERATING TEMPERATURE: 105°C [221°F]	THIS DRAWING IS A CONTROLLED DOCUMENT.		DWN DK SCHRUM 08/06/92	TE Connectivity NAME TERMINAL, RING TONGUE, PLASTI-GRIP, WIRE SIZE, 22-16 AWG				
FOR ADDITIONAL PRODUCT INFORMATION OR COPIES OF DRAWINGS AND TECHNICAL DOCUMENTS	PRODUCT INFORMATION CENTER 1-800-522-6752	VOLTAGE RATING: 600V MAX (1000V FIXTURE OR SIGN)	DIMENSIONS: mm[INCHES]	TOLERANCES UNLESS OTHERWISE SPECIFIED: 0 PLC ± - 1 PLC ± - 2 PLC ± 0.20[.008] 3 PLC ± - 4 PLC ± - ANGLES ± -	CHK RE HERSEY 11/10/92			APD M BARNABA 11/10/92	PRODUCT SPEC UL 486A	
FOR APPLICATION TOOLING INFORMATION	TOOLING ASSISTANCE CENTER 1-800-722-1111	CIRCULAR MIL AREA: 0.26-1.65mm² [509-3260] SOLID OR STRANDED	MATERIAL SEE TABLE	FINISH TIN PER ASTM B545	APPLICATION SPEC -	WEIGHT -	SIZE A3	CAGE CODE 00779	DRAWING NO C=34150	RESTRICTED TO -
FOR ORDER ENTRY	1-800-526-5142	THIS DRAWING IS A CONTROLLED DOCUMENT FOR AMP INCORPORATED. IT IS SUBJECT TO CHANGE AND THE CONTROLLING ENGINEERING ORGANIZATION SHOULD BE CONTACTED FOR THE LATEST REVISION.			CUSTOMER DRAWING		SCALE 4:1	SHEET 1 of 1	REV R2	