

THIS DRAWING IS UNPUBLISHED. RELEASED FOR PUBLICATION  
 © COPYRIGHT - By - ALL RIGHTS RESERVED.

LOC	DIST	REVISIONS			
P	LTR	DESCRIPTION	DATE	DWN	APVD
G	14	T2	REVISED PER ECO-11-004820	11MAR11	RK HMR

<b>AMP</b> WIRE RANGE	Listed FILE E13288	LR7189 Certified
22-16 AWG SOLID OR STRANDED	22-16 AWG SOLID OR STRANDED	22-16 AWG SOLID OR STRANDED

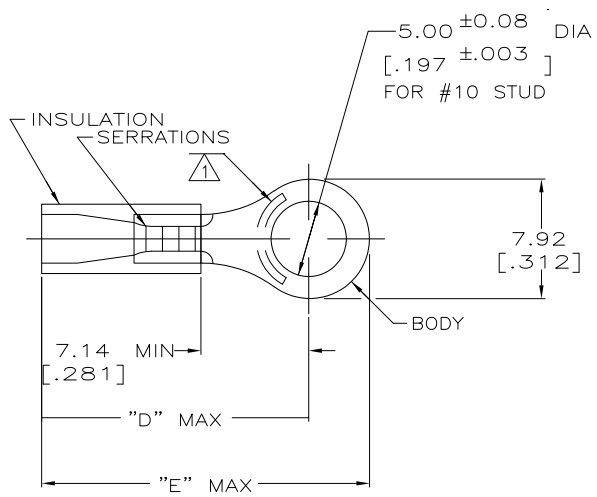

- 1 STAMP AMP 22-18\* 1-2 APPROX AS SHOWN  
22-16 TERMINALS ARE STAMPED 22-18 IN  
ACCORDANCE WITH MILITARY SPEC MIL-T-7928  
COMMERCIAL WIRE RANGE IS 22-16
- 2 TONGUE MATERIAL THK: 0.79 ± 0.05 [.031 ± .002]
- 3 PRELIMINARY - NOT FOR PRODUCTION.
- 4 MATERIAL: BODY - CU PER ASTM B152  
SLEEVE - PVC, COLOR - RED

"E"	"D"	WIRE INSULATION DIA	QTY	PACKAGE TYPE	PART NUMBER
21.74[.856]	17.70[.697]	2.67-3.56[.105-.140]	100	LOOSE PC, BOX	8-34149-1
22.99[.905]	18.95[.746]	2.67-5.08[.105-.200]	5000	ON TAPE, REEL	2-34149-3
21.74 [.856]	17.70 [.697]	2.67-3.56 [.105-.140]	5000	ON TAPE, REEL	2-34149-1
			1000	LOOSE PIECE	34149

<b>AMP INCORPORATED CUSTOMER SERVICE SYSTEMS</b>		MAX RECOMMENDED OPERATING TEMPERATURE: 105°C [221°F]	THIS DRAWING IS A CONTROLLED DOCUMENT.		DWN DK SCHRUM 08/06/92	<b>STE</b> TE Connectivity
FOR ADDITIONAL PRODUCT INFORMATION OR COPIES OF DRAWINGS AND TECHNICAL DOCUMENTS	PRODUCT INFORMATION CENTER 1-800-522-6752	VOLTAGE RATING: 600V MAX (1000V FIXTURE OR SIGN)	DIMENSIONS: mm [INCHES]	TOLERANCES UNLESS OTHERWISE SPECIFIED: 0 PLC ± - 1 PLC ± - 2 PLC ± 0.20[.008] 3 PLC ± - 4 PLC ± - ANGLES ± -	CHK RE HERSEY 11/10/92	
FOR APPLICATION	TOOLING ASSISTANCE CENTER 1-800-722-1111	CIRCULAR MIL AREA: 0.26-1.65mm² [509-3260] SOLID OR STRANDED	MATERIAL		APVD M BARNABA 11/10/92	PRODUCT SPEC UL 486A
FOR ORDER ENTRY	1-800-526-5142	FINISH TIN PER ASTM B545		APPLICATION SPEC		SIZE CAGE CODE DRAWING NO A3 00779 C=34149
THIS DRAWING IS A CONTROLLED DOCUMENT FOR AMP INCORPORATED. IT IS SUBJECT TO CHANGE AND THE CONTROLLING ENGINEERING ORGANIZATION SHOULD BE CONTACTED FOR THE LATEST REVISION.		MATERIAL		FINISH		RESTRICTED TO
		- 4		CUSTOMER DRAWING		SCALE 4:1 SHEET 1 of 1 REV T2