

THIS DRAWING IS UNPUBLISHED. RELEASED FOR PUBLICATION
 © COPYRIGHT - By - ALL RIGHTS RESERVED.

LOC	DIST	REVISIONS			
P	LTR	DESCRIPTION	DATE	DWN	APVD
G	14	N1	REVISED PER ECO-11-004917	11MAR11	RK HMR

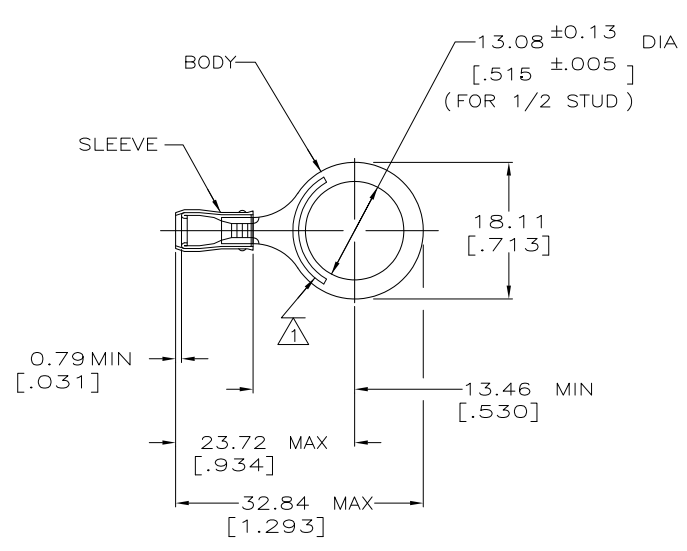

AMP WIRE RANGE	E13288 Listed	LR7189 Certified
22-16 AWG SOLID OR STRANDED	22-16 AWG SOLID OR STRANDED	22-16 AWG SOLID OR STRANDED

- 1 STAMP AMP 22-18* APPROX AS SHOWN
22-16 TERMINALS ARE STAMPED 22-18 IN
ACCORDANCE WITH MILITARY SPEC MIL-T-7928
COMMERCIAL WIRE RANGE IS 22-16
- 2 WIRE INSULATION DIA: 2.03 - 3.18
[.080 - .125]
- 3 TONGUE MATERIAL THK: 0.79±0.05
[.031±.002]

-	-	100	LOOSE PIECE, BOX	8-328975-1
MS25036-151	MS25036-151	1000	LOOSE PIECE	328975
MILITARY P/N AND CLASS		QUANTITY	PACKAGE TYPE	PART NO

AMP INCORPORATED CUSTOMER SERVICE SYSTEMS		MAX RECOMMENDED OPERATING TEMPERATURE: 105° C MAX	THIS DRAWING IS A CONTROLLED DOCUMENT.		DWN DK SCHRUM 9/8/93	TE Connectivity
FOR ADDITIONAL PRODUCT INFORMATION OR COPIES OF DRAWINGS AND TECHNICAL DOCUMENTS	PRODUCT INFORMATION CENTER 1-800-522-6752	VOLTAGE RATING: 300 V MAX	DIMENSIONS: MM(INCHES)	TOLERANCES UNLESS OTHERWISE SPECIFIED:	CHK RE HERSEY 9/8/93	
FOR APPLICATION TOOLING INFORMATION	TOOLING ASSISTANCE CENTER 1-800-722-1111	CIRCULAR MIL AREA: 0.26-1.65mm² [509-3,260] CIR MILS SOLID OR STRANDED		0 PLC ± - 1 PLC ± - 2 PLC ± 0.20[.008] 3 PLC ± - 4 PLC ± - ANGLES ± -	APVD ML ELLIS 9/8/93	
FOR ORDER ENTRY	1-800-526-5142	THIS DRAWING IS A CONTROLLED DOCUMENT FOR AMP INCORPORATED. IT IS SUBJECT TO CHANGE AND THE CONTROLLING ENGINEERING ORGANIZATION SHOULD BE CONTACTED FOR THE LATEST REVISION.	MATERIAL COPPER PER ASTM B-152 SLEEVE, RED NYLON	FINISH TIN PLATE PER ASTM B545	PRODUCT SPEC UL 486A	NAME TERMINAL, RING TONGUE, PIDG™, WIRE SIZE, 22-16 AWG
					APPLICATION SPEC NOT AVAILABLE	SIZE A3
					WEIGHT -	CAGE CODE 00779
					CUSTOMER DRAWING	DRAWING NO C=328975
						RESTRICTED TO -
						SCALE NTS
						SHEET 1 of 2
						REV N1

THIS DRAWING IS UNPUBLISHED. RELEASED FOR PUBLICATION
 © COPYRIGHT - By - ALL RIGHTS RESERVED.

LOC	DIST	REVISIONS					
G	14	P	LTR	DESCRIPTION	DATE	DWN	APVD
		-		SEE SHEET 1	-	-	-

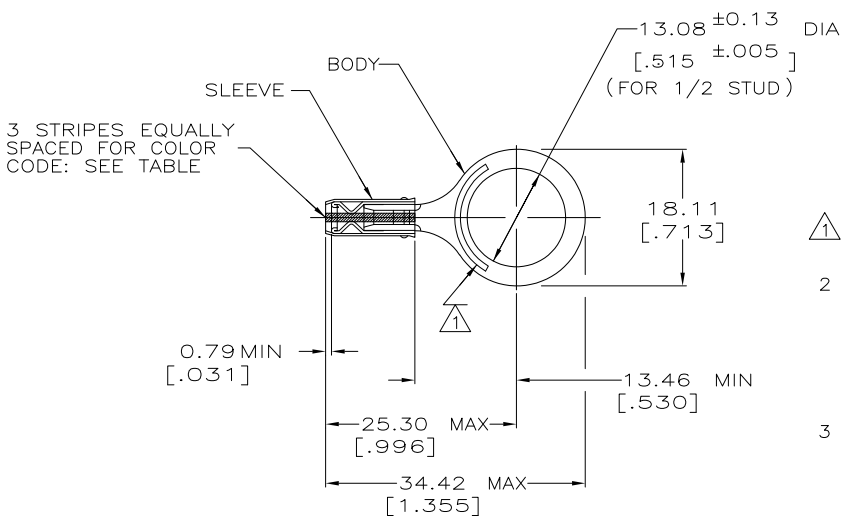

AMP
WIRE RANGE

SEE TABLE
STRANDED

- 2 WIRE INSULATION DIA: 0.97 - 2.79 FOR 22 AWG
 [0.038 - .110]
 1.17 - 2.79 FOR 20 AWG
 [0.046 - .110]
 1.42 - 2.79 FOR 18 AWG
 [0.056 - .110]
- 3 TONGUE MATERIAL THK: 0.79±0.05
 [0.031±0.002]

M7928/1-37 CLASS 1 & 2	WHITE	18*	18	1000	LOOSE PIECE	2-328975-3
M7928/1-28 CLASS 1 & 2	RED	20*	20	1000	LOOSE PIECE	2-328975-2
M7928/1-19 CLASS 1 & 2	GREEN	22*	22	1000	LOOSE PIECE	2-328975-1
MILITARY P/N AND CLASS	STRIPE COLOR	△ STAMPING	WIRE SIZE	QUANTITY	PACKAGE TYPE	PART NO

AMP INCORPORATED CUSTOMER SERVICE SYSTEMS		MAX RECOMMENDED OPERATING TEMPERATURE: 105° C MAX	THIS DRAWING IS A CONTROLLED DOCUMENT.		DWN DK SCHRUM 9/8/93	TE Connectivity		
FOR ADDITIONAL PRODUCT INFORMATION OR COPIES OF DRAWINGS AND TECHNICAL DOCUMENTS	PRODUCT INFORMATION CENTER 1-800-522-6752	VOLTAGE RATING: 300 V MAX	DIMENSIONS: MM(INCHES)	TOLERANCES UNLESS OTHERWISE SPECIFIED:	CHK RE HERSEY 9/8/93	NAME		
FOR APPLICATION	TOOLING ASSISTANCE CENTER	WIRE RANGE: CIRC MIL AREA		0 PLC ± -	APVD ML ELLIS 9/8/93	TERMINAL, RING TONGUE, I.R., PIDG™ WIRE SIZE, 22-16 AWG		
TOOLING INFORMATION	1-800-722-1111	22 0.38mm² [754] 20 0.60mm² [1,186] 18 0.96mm² [1,900]		1 PLC ± - 2 PLC ± - [0.20(.008)] 3 PLC ± - 4 PLC ± - ANGLES ± -	PRODUCT SPEC	APPLICATION SPEC	SIZE	CAGE CODE
FOR ORDER ENTRY	1-800-526-5142	STRANDED	MATERIAL COPPER PER ASTM B-152 SLEEVE, RED NYLON	FINISH TIN PLATE PER ASTM B545	NOT AVAILABLE	WEIGHT	A3 00779	DRAWING NO C=328975
THIS DRAWING IS A CONTROLLED DOCUMENT FOR AMP INCORPORATED. IT IS SUBJECT TO CHANGE AND THE CONTROLLING ENGINEERING ORGANIZATION SHOULD BE CONTACTED FOR THE LATEST REVISION.					CUSTOMER DRAWING	SCALE	NTS	SHEET 2 of 2
								REV N1