

4

3

2

1

THIS DRAWING IS UNPUBLISHED.

RELEASED FOR PUBLICATION

ALL RIGHTS RESERVED.

LOC
G 14

REVISIONS

P	LTR	DESCRIPTION	DATE	DWN	APVD
G2		REVISED PER ECO-11-005027	11MAR11	RK	HMR

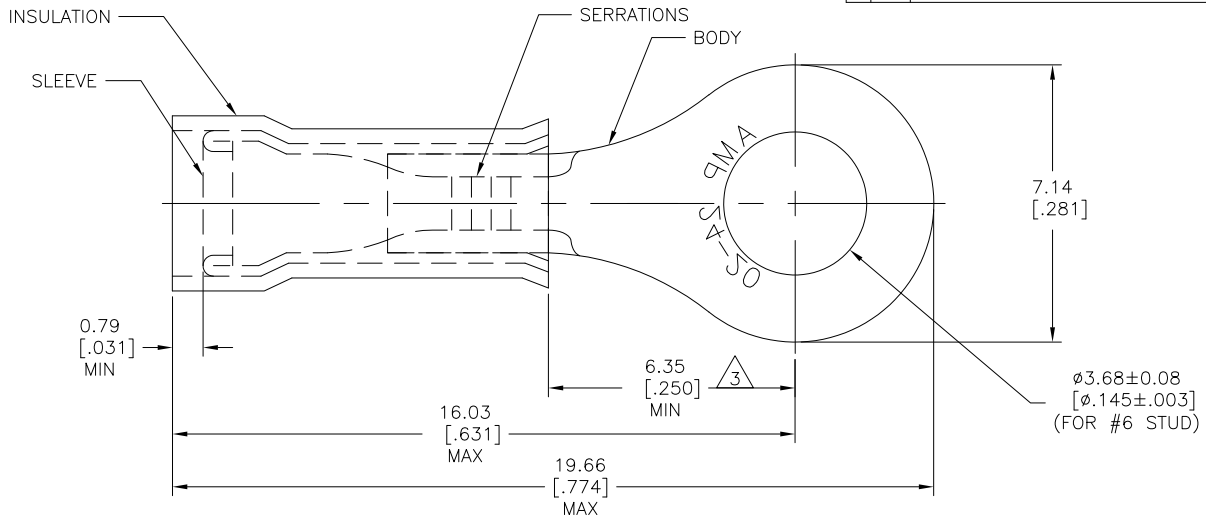

1 FOR 1.02[.040] TO 2.54[.100] WIRE INSULATION DIA

2 TONGUE MATERIAL THK 0.58±0.05[.023±.002]

△ 3 APPLIES FROM EDGE OF METAL BARREL TO CENTERLINE OF STUD HOLE.

QTY	DESCRIPTION	MATERIAL & FINISH	PART NO
1	2-323986-2 ON TAPE	BODY&SLEEVE: COPPER ASTM-B152 TIN PL ASTM-B545	2-323986-3
1	WIRE TERMINAL	INSULATION: BLACK NYLON ASTM-D4066 TYPE I	2-323986-2
1	323986 ON TAPE	BODY&SLEEVE: COPPER ASTM-B152 TIN PL ASTM-B545	2-323986-1
1	WIRE TERMINAL	INSULATION: NATURAL NYLON ASTM-D4066 TYPE I	323986

THIS DRAWING IS A CONTROLLED DOCUMENT.		DWN RAGHAVENDRA 19MAR10	19MAR10		STE TE Connectivity
DIMENSIONS: mm [INCHES]		CHK JEFF RUTH 19MAR10	APVD TOM MICHIELUTTI 19MAR10		
TOLERANCES UNLESS OTHERWISE SPECIFIED:		PRODUCT SPEC		TERMINAL, NYLON - PIDG - RING TONGUE WIRE SIZE: 24-20	
0 PLC ± -		APPLICATION SPEC		RESTRICTED TO	
1 PLC ± -		WEIGHT		SIZE	
2 PLC ± -		CAGE CODE		DRAWING NO	
3 PLC ± 0.20 [.008]		A3 00779		C=323986	
4 PLC ± -		CUSTOMER DRAWING		SCALE 10:1	
ANGLES ± 0° 30'		SHEET 1 OF 1		REV G2	
MATERIAL SEE TABLE		FINISH SEE TABLE			

1470-19 (3/11)