

THE DRAWING IS UNPUBLISHED.
 © COPYRIGHT - By -
 RELEASED FOR PUBLICATION
 ALL RIGHTS RESERVED.

LOC	QTY	REV	DESCRIPTION	SU	DATE	DRW	APPD
G	14	P	LR				
		C1	REVISED PER ECO-11-004917		11MAR11	RK	HMR

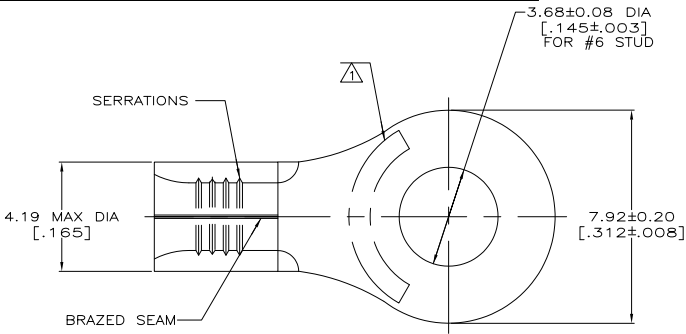

AMP WIRE RANGE	E13288 Listed
16-14 AWG SOLID OR STRANDED	16-14 AWG SOLID OR STRANDED
LR7189 Certified	MILITARY P/N AND CLASS
16-14 AWG SOLID OR STRANDED	M7928/7-7 CLASS 2 P/N 321684 & 2-321684-1 ONLY

△ STAMP AMP 16-14* APPROX AS SHOWN

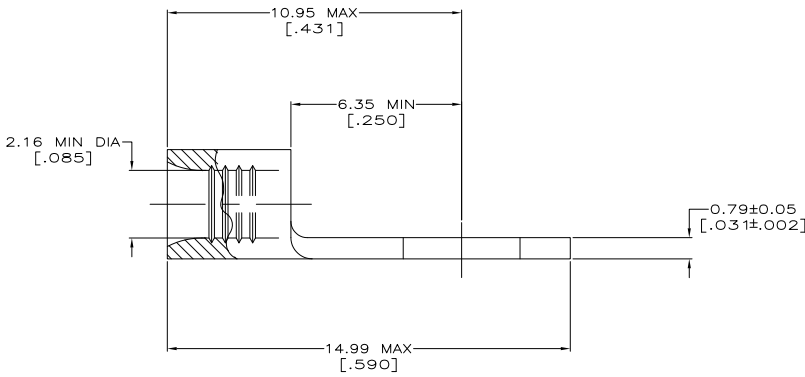

AMP INCORPORATED CUSTOMER SERVICE SYSTEMS

MAX RECOMMENDED OPERATING TEMPERATURE:
170° C MAX

FOR ADDITIONAL PRODUCT INFORMATION OR COPIES OF DRAWINGS AND TECHNICAL DOCUMENTS

PRODUCT INFORMATION CENTER
1-800-522-6752

VOLTAGE RATING:
NOT APPLICABLE

FOR APPLICATION TOOLING INFORMATION

TOOLING ASSISTANCE CENTER
1-800-722-1111

WIRE CROSS SECTIONAL AREA RANGE:
1.04-2.62mm² [2,050-5,180] CIR MILS
SOLID OR STRANDED

FOR ORDER ENTRY

1-800-526-5142

THIS DRAWING IS A CONTROLLED DOCUMENT FOR AMP INCORPORATED. IT IS SUBJECT TO CHANGE AND THE CONTROLLING ENGINEERING ORGANIZATION SHOULD BE CONTACTED FOR THE LATEST REVISION.

100	LOOSE PIECE, BOX	8-321684-1
5000	ON TAPE	2-321684-1
---	LOOSE PIECE	321684
QUANTITY	PACKAGING TYPE	PART NO

THIS DRAWING IS A CONTROLLED DOCUMENT.		BY TA BRINKMAN 3-17-93	TE Connectivity
DRAWING NO. 321684		CHK DA PATTERSON 3-17-93	
DIMENSIONS: MM(INCHES)		APP'D DE MILLER 3-17-93	NAME TERMINAL, RING TONGUE, SOLISTRAND™
TOLERANCES UNLESS OTHERWISE SPECIFIED:		PRODUCT SPEC	
Ø	1 P/C	± .005	APPLICATION SPEC
1	2 P/C	± .005	
2	3 P/C	± .005	
3	4 P/C	± .005	
MATERIAL: COPPER PER ASTM B-152 ANNEALED		FINISH: TIN PLATE 0.0025(64.00125) MIN THK PER ASTM B-545	SIZE: A2
WEIGHT		00779	DRAWING NO: 321684
CUSTOMER DRAWING		SCALE: 10:1	SHEET: 1 of 1
		REV: C1	RESTRICTED TO: ---