

DRAWING MADE IN AMERICAN PROJECTION

© 1967 BY AMP INCORPORATED. ALL RIGHTS RESERVED. AMP PRODUCTS COVERED BY PATENTS AND/OR PATENTS PENDING.

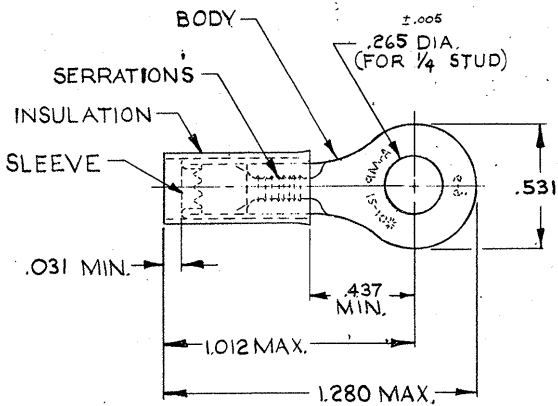

FOR .102 TO .214 WIRE INSULATION DIA.
TONGUE MATERIAL THK. = .040 ±.002

REVISIONS				
ZONE	LTR	DESCRIPTION	DATE	APPROVED
	B	REDRAWN & REV.	P.6077 SR 7-30-69	FCY
	C	REVISED	PC-5579 WM 10-8-70	AME
	D	REVISED	PC-5578 TR 2-23-77	L.D.
	E	REV/0610-0094-98	2-4-99	ME/SP
	E1	REV P&L ECR 05-013140	10/20/05	KE/TM

1	WIRE TERMINAL	50846	BODY: COPPER (ASTM B152) NICKEL PLATE (QQ-N-290) .0003 AVG EXT THK.
			SLEEVE: COPPER (ASTM B152) NICKEL PL (QQ-N-290).00003 AVG. EXT. THK.
			INSULATION: TEFLON (ASTM D3292) COLOR: BLACK
QTY	DESCRIPTION	PART NO.	MATERIAL & FINISH
UNLESS OTHERWISE SPECIFIED DIMENSIONS ARE IN INCHES TOLERANCES ON: DECIMALS ±.008 ANGLES ± 5°		CONTRACT NO. 4	AMP INCORPORATED HARRISBURG, PENNSYLVANIA
MATERIAL		DR. <i>[Signature]</i> 7-29-69	
SEE TABLE		CHK. <i>[Signature]</i> 7-29-69	NAME
		APPD. <i>[Signature]</i> 8-6-69	WIRE TERMINAL
		REL. <i>[Signature]</i> 8-6-69	PIDG™ STRATO-THERM - RING TONGUE
		DSGN APPD.	WIRE SIZE: 12-10
		OTHER APPD.	SIZE B CODE IDENT NO. 00779 NUMBER 50846
			SCALE NTS SHEET 10F1