

REV	DATE	APP'D	DESCRIPTION
1	3-17-93		
2			
3			
4			
5			
6			
7			
8			
9			
10			
11			
12			
13			
14			
15			
16			
17			
18			
19			
20			
21			
22			
23			
24			
25			
26			
27			
28			
29			
30			
31			
32			
33			
34			
35			
36			
37			
38			
39			
40			
41			
42			
43			
44			
45			
46			
47			
48			
49			
50			
51			
52			
53			
54			
55			
56			
57			
58			
59			
60			
61			
62			
63			
64			
65			
66			
67			
68			
69			
70			
71			
72			
73			
74			
75			
76			
77			
78			
79			
80			
81			
82			
83			
84			
85			
86			
87			
88			
89			
90			
91			
92			
93			
94			
95			
96			
97			
98			
99			
100			

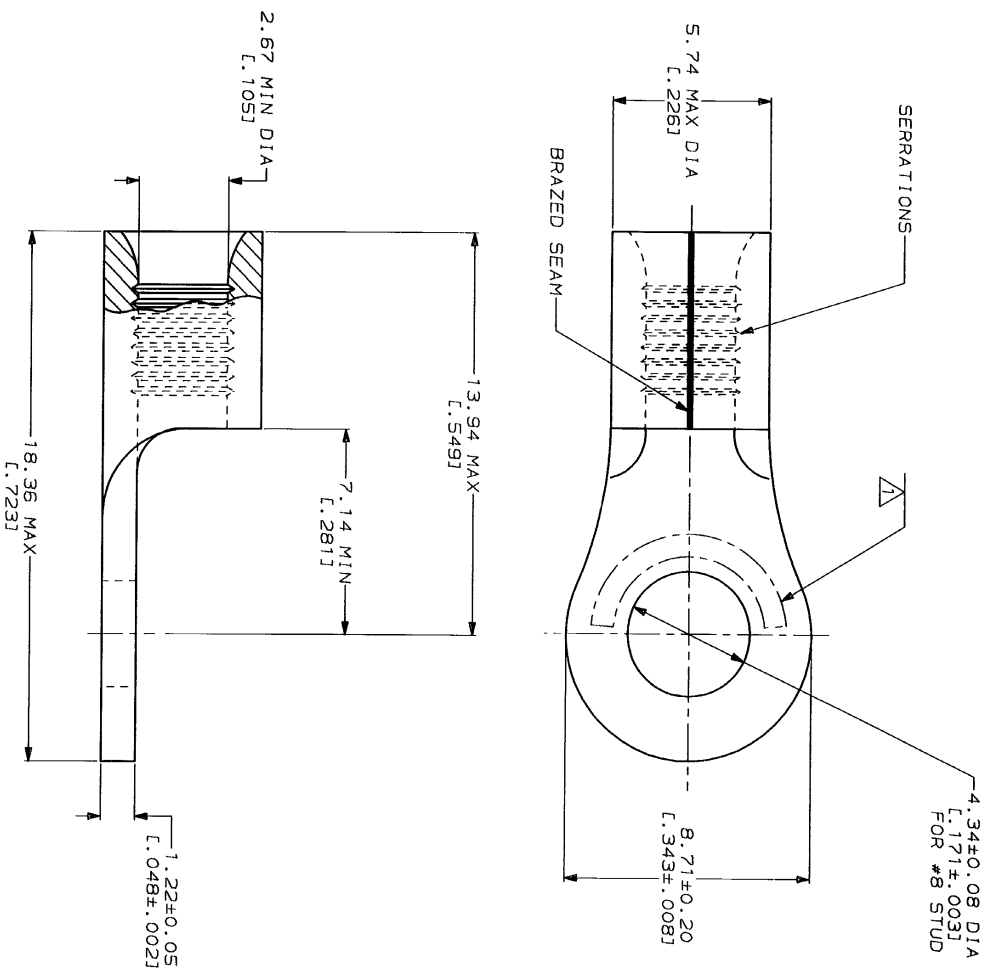

AMP WIRE RANGE	UL E13288 Listed
16-14HD AWG SOLID OR STRANDED	16-14HD AWG STRANDED
LR7189 Certified	MILITARY P/N AND CLASS
16-14HD AWG SOLID OR STRANDED	NOT APPLICABLE

△ STAMP AMP 16-14HD* APPROX AS SHOWN



AMP INCORPORATED CUSTOMER SERVICE SYSTEMS	
FOR ADDITIONAL PRODUCT INFORMATION OR COPIES OF DRAWINGS AND TECHNICAL DOCUMENTS	PRODUCT INFORMATION CENTER 1-800-522-6752
FOR APPLICATION TOOLING INFORMATION	TOOLING ASSISTANCE CENTER 1-800-722-1111
FOR ORDER ENTRY	1-800-526-5142
MAX RECOMMENDED OPERATING TEMPERATURE:	170°C MAX
VOLTAGE RATING:	NOT APPLICABLE
WIRE CROSS SECTIONAL AREA RANGE:	1.04-2.62mm ² [2.050-5.180] CIR MILS
THIS DRAWING IS A CONTROLLED DOCUMENT FOR MILITARY AND AEROSPACE APPLICATIONS. FOR THE CONTROLLING ENGINEERING ORGANIZATION, PLEASE SEE DRAWING REV. 10/19/93.	

DO NOT SCALE PRINT. DIMENSIONS SPECIFIED UNLESS OTHERWISE TOLERANCES ON: 3 PLG DEC ± . 3 PLG DEC ± .	DR 3-17-93 BL KRUBER CHK 3-17-93 DA PATTERSON APPD 3-17-93 DE MILLER APPD 3-17-93 JL MECKLEY PRODUCT SPEC
FINISH: TIN PLATE 0.00254L [0.00100] MIN THK PER MIL-T-10727	APPLICATION SPEC

NAME	AMP Incorporated Harrisburg, PA 17105-3608
SIZE	CAGE CODE 00779 DRAWING NO 35432
SCALE	8:1
SHEET	1 OF 1