

THIS DRAWING IS UNPUBLISHED. RELEASED FOR PUBLICATION
 © COPYRIGHT 19 BY AMP INCORPORATED. ALL INTERNATIONAL RIGHTS RESERVED.

LOC	DIST	P	F	ZONE	LTR	REVISIONS	DATE	APPD
G	14					A REV & REDRAWN PER 0720-0061-93	4-19-93	JL MECKLEY

METRIC
 DIMENSIONS LISTED IN mm [INCHES]

AMP WIRE RANGE	E13288 Listed
22-16 AWG SOLID OR STRANDED	NOT APPLICABLE
LR7189 Certified	MILITARY P/N AND CLASS
NOT APPLICABLE	NOT APPLICABLE

⚠ STAMP AMP 22-18* APPROX AS SHOWN
 22-16 TERMINALS ARE STAMPED 22-18 IN
 ACCORDANCE WITH MILITARY SPECIFICATION
 MIL-T-7928; COMMERCIAL WIRE RANGE IS 22-16

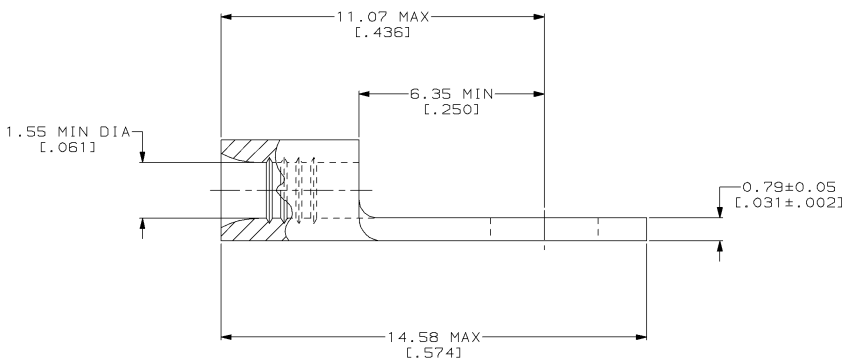
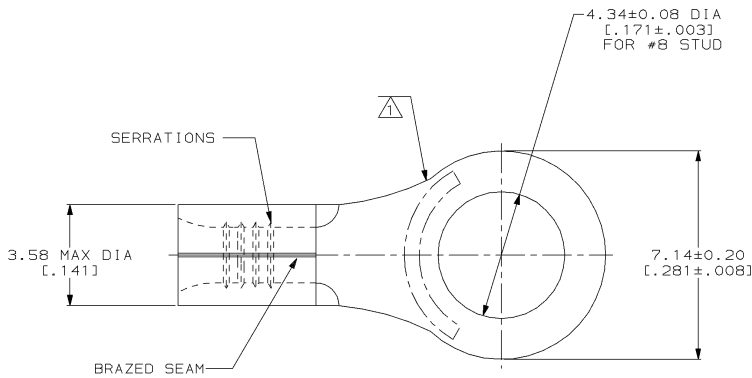

AMP INCORPORATED CUSTOMER SERVICE SYSTEMS		MAX RECOMMENDED OPERATING TEMPERATURE: 343°C MAX	DO NOT SCALE PRINT. UNLESS SPECIFIED DIMENSIONS IN mm (INCHES) TOLERANCES ON: 2 PLC DEC ± - 3 PLC DEC ± - ANGLES ± -	DR 4-19-93 TA BRINKMAN CHK 4-19-93 DA PATTERSON APPD 4-19-93 DE MILLER APPD 4-19-93 JL MECKLEY PRODUCT SPEC	322798 PART NO
FOR ADDITIONAL PRODUCT INFORMATION OR COPIES OF DRAWINGS AND TECHNICAL DOCUMENTS	PRODUCT INFORMATION CENTER 1-800-522-6752	VOLTAGE RATING: NOT APPLICABLE	MATERIAL COPPER PER ASTM B-152 ANNEALED	NAME AMP Incorporated Harrisburg, PA 17105-3608	AMP AMP Incorporated Harrisburg, PA 17105-3608 TERMINAL, RING TONGUE, HEAT RESISTANT, STRATO-THERM™
FOR APPLICATION TOOLING INFORMATION	TOOLING ASSISTANCE CENTER 1-800-722-1111	WIRE CROSS SECTIONAL AREA RANGE: 0.26-1.65mm ² [509-3,260] CIR MILS SOLID OR STRANDED	FINISH NICKEL PLATE 0.00762[.000300] MIN THK PER QQ-N-290	SIZE CAGE CODE DRAWING NO 00779 C-322798	
FOR ORDER ENTRY	1-800-526-5142	THIS DRAWING IS A CONTROLLED DOCUMENT FOR AMP INCORPORATED. IT IS SUBJECT TO CHANGE AND THE CONTROLLING ENGINEERING ORGANIZATION SHOULD BE CONTACTED FOR THE LATEST REVISION.	APPLICATION SPEC WEIGHT	SCALE 10:1 SHEET 1 OF 1	

AMP 1471-6 REV 3-92
 02_AUG_1993 07:35:57 AMP26463 <U5128A>DEPT1123>DWG1123>U,STRATO-THERM,U,TERMINALS

CUSTOMER DRAWING